

DP33-13-11 (DP10k - BPK)

KUREK KULOWY OGRZEWANY NA CAŁEJ DŁUGOŚCI KOŁNIERZOWY Z PEŁNYM PRZELOTEM



ZAKRES ŚREDNIC
DN15 ÷ DN300



CIŚNIENIE
PN16 ÷ PN40



TEMPERATURA
-50°C ÷ +250°C

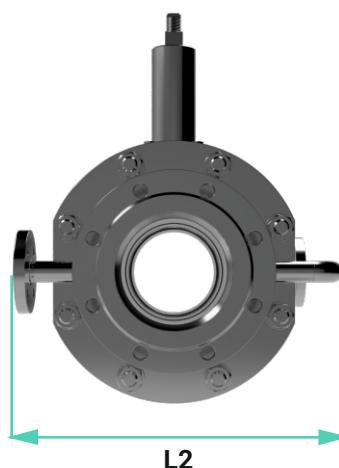
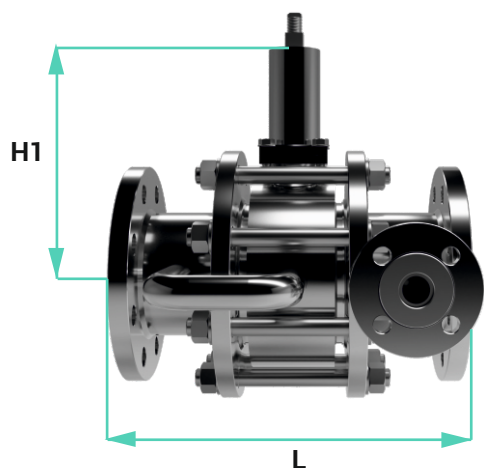

| DN | 15 | 20 | 25 | 32 | 40 | 50 | 65 | 80 | 100 | 125 | 150 | 200 | 250 | 300 |
|-------------------|------|------|------|------|------|------|------|------|------|------|------|------|------|------|
| Przełot | 15,9 | 20 | 25 | 32 | 40 | 50 | 62 | 75 | 102 | 125 | 150 | 200 | 250 | 300* |
| L-długość | 130* | 150 | 160 | 180 | 200 | 230 | 290 | 310 | 350 | 400 | 600 | 730 | 850 | 850* |
| L1-szerokość | 235 | 250 | 250 | 220 | 234 | 271 | 281 | 304 | 326 | 485 | 486 | 545 | 700 | 750 |
| Kołnierz grzewczy | DN15 | DN15 | DN15 | DN15 | DN15 | DN15 | DN15 | DN15 | DN15 | DN20 | DN20 | DN20 | DN20 | DN25 |
| Masa (kg) | 3,6 | 5,2 | 5,7 | 7 | 9 | 14 | 17 | 26 | 33 | 44 | 66 | 92,5 | 172 | 240* |
| H1-wysokość | 144 | 157 | 157 | 161 | 165 | 191 | 202 | 210 | 245 | 266 | 313 | 338 | 401 | 431 |
| Sterowanie | NP/D | NP/D | NP/D | NP/D | NP/D | NP/D | NP/D | NP/D | NP/D | NP/D | NP/P | NP/P | NP/P | NP/P |

NP/D - dźwignia oraz przystosowanie do montażu napędu NP/P - przekładnia ręczna

WYKONANIE

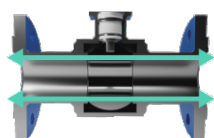

PEŁNY PRZELOT

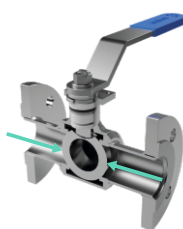

KLASA SZCZELNOŚCI A

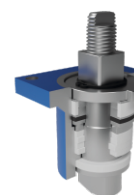

DŁAWICA BEZOBSŁUGOWA

STEROWANIE



DŹWIGNIA



PRZEKŁADNIA RĘCZNA



NAPĘD ELEKTRYCZNY LUB PNEUMATYCZNY

OPCJA



TA - LUFT
PN-EN ISO 15848-1
VDI 2440

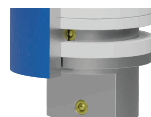

ATEX
2014/34/UE
ANTYSTATYCZNY

WERSJE MATERIAŁOWE

| Rodzaj materiału | Stal węglowa | | Stal stopowa nierdzewna | | | | | | | | | | Inne |
|-------------------------|---------------------------------|-----------|-------------------------|--------|--------|--------|--------|--------|--------|--------|-----------|--------------|------------------------|
| Oznaczenie | 11 | 12 | 21 | 22 | 23 | 24 | 25 | 26 | 41 | 42 | 43 Duplex | 44 Hastelloy | |
| Kadłub (korpus) | P355/S355 | P235/S235 | 1.4541 | 1.4301 | 1.4571 | 1.4571 | 1.4571 | 1.4404 | 1.4539 | 1.4931 | 1.4462 | 2.4602 | według wymagań Klienta |
| Przyłącze | P355/S355 | P235/S235 | 1.4541 | 1.4301 | 1.4541 | 1.4571 | 1.4571 | 1.4571 | 1.4539 | 1.4931 | 1.4462 | 2.4602 | |
| Organ zamykający (kula) | 1.4301 | 1.4301 | 1.4301 | 1.4301 | 1.4301 | 1.4404 | 1.4571 | 1.4404 | 1.4539 | 1.4931 | 1.4462 | 2.4602 | |
| Wał (trzcień) | 1.4305 | 1.4305 | 1.4305 | 1.4305 | 1.4305 | 1.4404 | 1.4571 | 1.4404 | 1.4539 | 1.4931 | 1.4462 | 2.4602 | |
| Uszczelnienie kuli | PTFE, PTFE + włókno szklane 25% | | | | | | | | | | | | |
| Pakiet uszczelniający | PTFE, PTFE + włókno szklane 25% | | | | | | | | | | | | |

STEROWANIE KURKÓW KULOWYCH - DŹWIGNIA

| DN | W | H1 | s | Typ | Funkcja |
|--------------|-----|----|---------|-----|----------|
| 15 | 147 | 48 | 8 x 8 | A | standard |
| 20 - 25 - 32 | 167 | 59 | 10 x 10 | A | |
| 40 | 217 | 59 | 10 x 10 | A | |
| 50 | 280 | 61 | 17 x 17 | A | |
| 65 - 80 | 360 | 61 | 17 x 17 | A | |
| 100 - 125 | 472 | 23 | 24 x 24 | B | |
| 150 | 672 | 23 | 24 x 24 | B | opcja |

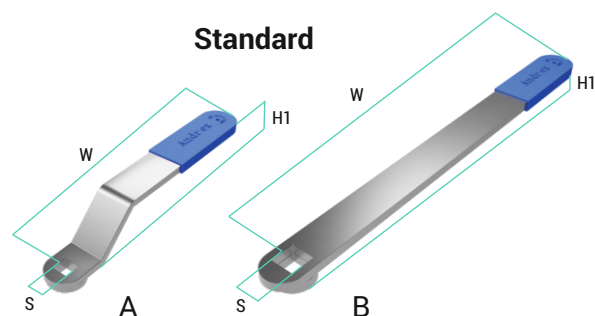

STEROWANIE KURKÓW KULOWYCH - KOLUMNA

| DN | S | a | H standard | Typ | H max |
|-----|---------|----|------------|-----------|-----------------------|
| 15 | 8 x 8 | 5 | 100 | KL1 - 100 | zgodnie z zamówieniem |
| 20 | 10 x 10 | 5 | 100 | KL2 - 100 | |
| 25 | 10 x 10 | 5 | 100 | KL2 - 100 | |
| 32 | 10 x 10 | 5 | 100 | KL2 - 100 | |
| 40 | 10 x 10 | 5 | 100 | KL2 - 100 | |
| 50 | 17 x 17 | 6 | 100 | KL3 - 100 | |
| 65 | 17 x 17 | 6 | 100 | KL3 - 100 | |
| 80 | 17 x 17 | 6 | 100 | KL3 - 100 | |
| 100 | 24 x 24 | 8 | 100 | KL4 - 100 | |
| 125 | 24 x 24 | 8 | 100 | KL4 - 100 | |
| 150 | 24 x 24 | 8 | 100 | KL4 - 100 | |
| 200 | 42 x 42 | 12 | 100 | KL5 - 100 | |
| 250 | 42 x 42 | 12 | 100 | KL5 - 100 | |

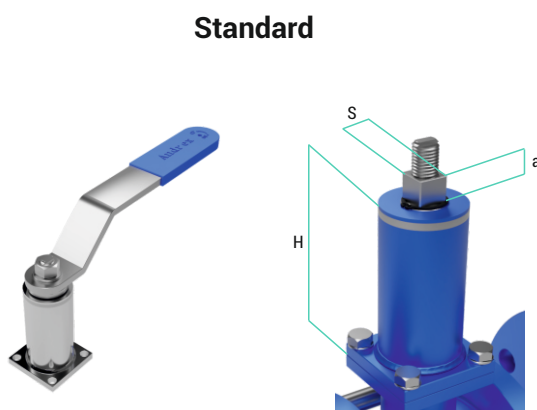

OPCJE WYKONANIA STEROWANIA



z możliwością zastosowania
kłódki, plomby

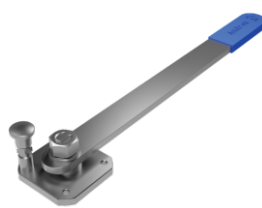

z zabezpieczeniem przed
przypadkowym przesterowaniem



z czujnikami
sygnalizacji krańcowej



z grzechotką



kwasoodporna



przesunięta w poziomie



wykonanie specjalne

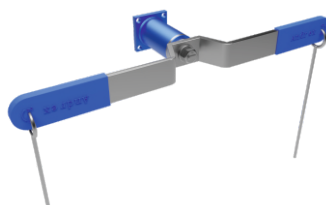

dźwignia sprężysta

STEROWANIE KURKÓW KULOWYCH PRZEKŁADNIA RĘCZNA**



standard



z kolumną



z czujnikami sygnalizacji
krańcowej



z łańcuchem

NAPĘD PNEUMATYCZNY** NAPĘD ELEKTRYCZNY**

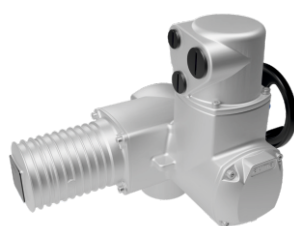

- jednostronny
- jednostronny z czujnikami sygnalizacji krańcowej
- jednostronny z czujnikami sygnalizacji krańcowej i elektrozaworem
- dwustronny z czujnikami sygnalizacji krańcowej
- dwustronny z czujnikami sygnalizacji krańcowej i elektrozaworem
- wykonanie specjalne

** wymiary dostępne na zapytanie

PRZYSTOSOWANIE POD NAPĘD

| DN | d1 | d3 | S | a | H | Typ | H max |
|-----|-----|-----|---------|------|----|------|-------|
| 15 | 65 | 50 | 14 x 14 | 14 | 50 | F 05 | |
| 20 | 65 | 50 | 14 x 14 | 15 | 75 | F 05 | |
| 25 | 65 | 50 | 14 x 14 | 15 | 75 | F 05 | |
| 32 | 65 | 50 | 14 x 14 | 15 | 75 | F 05 | |
| 40 | 65 | 50 | 14 x 14 | 15 | 75 | F 05 | |
| 50 | 90 | 70 | 17 x 17 | 18 | 60 | F 07 | |
| 65 | 90 | 70 | 17 x 17 | 18 | 60 | F 07 | |
| 80 | 90 | 70 | 17 x 17 | 18 | 60 | F 07 | |
| 100 | 125 | 102 | 22 x 22 | 25 | 76 | F 10 | |
| 125 | 125 | 102 | 22 x 22 | 25 | 76 | F 10 | |
| 150 | 125 | 102 | 22 x 22 | 25 | 76 | F 10 | |
| 200 | 150 | 125 | 27 x 27 | 30,5 | 97 | F 12 | |
| 250 | 150 | 125 | 27 x 27 | 30,5 | 97 | F 12 | |

zgodnie z zamówieniem

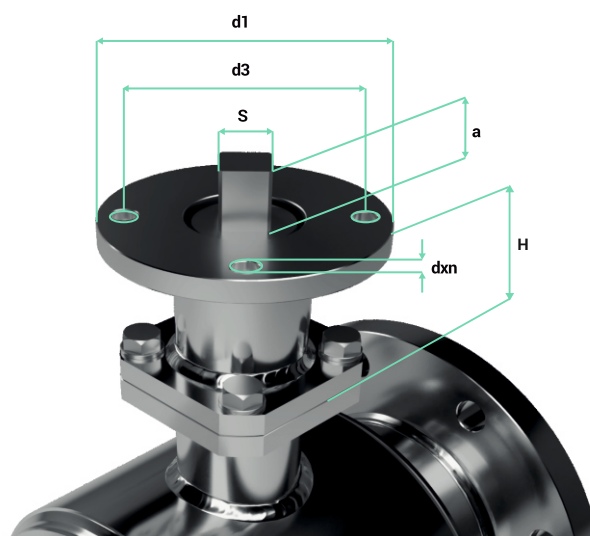

PRZYSTOSOWANIE POD WYPOSAŻENIE OPCJONALNE

| DN | D | D1 | □A | g | dxn | Funkcja |
|-----|-----|-----|----|----|-------|---------|
| 15 | 56 | 42 | 50 | 8 | M6x4 | |
| 20 | 65 | 50 | 50 | 8 | M6x4 | |
| 25 | 65 | 50 | 50 | 8 | M6x4 | opcja |
| 32 | 65 | 50 | 50 | 8 | M6x4 | |
| 40 | 65 | 50 | 50 | 8 | M6x4 | |
| 50 | 70 | 70 | 62 | 8 | M8x4 | |
| 65 | 70 | 70 | 62 | 8 | M8x4 | |
| 80 | 70 | 70 | 62 | 8 | M8x4 | |
| 100 | 110 | 90 | 90 | 10 | M10x4 | |
| 125 | 110 | 90 | 90 | 10 | M10x4 | |
| 150 | 110 | 90 | 90 | 10 | M10x4 | |
| 200 | 175 | 140 | - | 17 | M16x4 | |
| 250 | 175 | 140 | - | 17 | M16x4 | |

standard

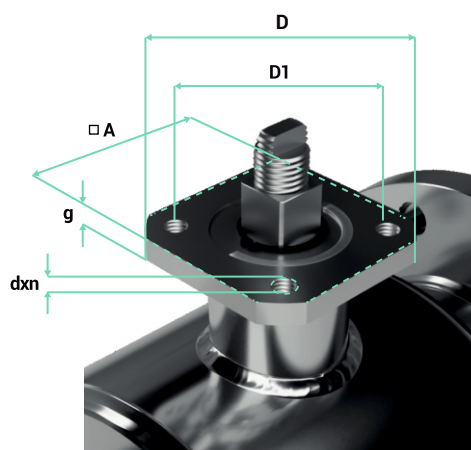

MOMENTY OBROTOWE KURKA

| DN | 15 | 20 | 25 | 32 | 40 | 50 | 65 | 80 | 100 | 125 | 150 | 200 | 250 |
|--|----|----|-----|----|-----|----|-----|-----|------|------|-----|------|-----|
| Moment obrotowy (Nm)* | 10 | 15 | 20 | 25 | 40 | 80 | 100 | 120 | 150 | 190 | 350 | 550 | 800 |
| Maksymalny dopuszczalny moment obrotowy (Nm)** | 40 | | 120 | | 140 | | 300 | | 1000 | 1200 | | 1300 | |

* zakładany moment obrotowy w warunkach montażu. W celu doboru odpowiedniego silownika proszę o kontakt z producentem

** następuje uszkodzenie kurka

WYMIARY KOŁNIERZY WG NORMY PN-EN 1092-1

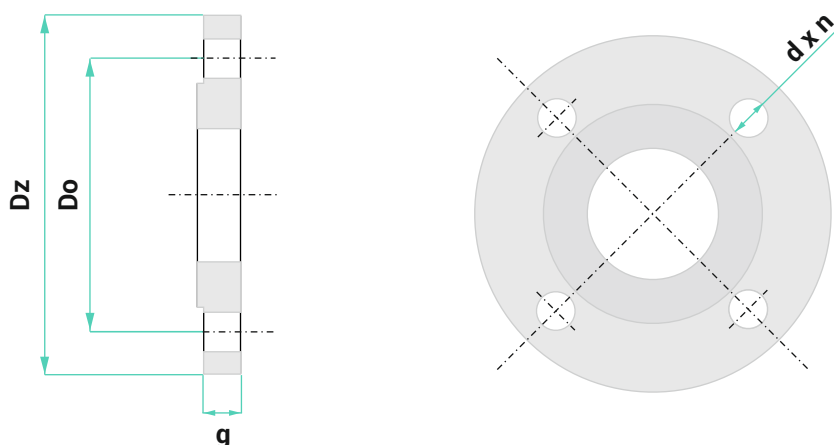

| DN | 10 | 15 | 20 | 25 | 32 | 40 | 50 | 65 | 80 | 100 | 125 | 150 | 200 | 250 | 300 |
|----|----|----|----|----|----|----|----|----|----|-----|-----|-----|-----|-----|-----|
|----|----|----|----|----|----|----|----|----|----|-----|-----|-----|-----|-----|-----|

Kołnierze wg PN-EN 1092-1; PN 6

| | | | | | | | | | | | | | | | |
|-----|--------|--------|--------|--------|--------|--------|--------|--------|--------|--------|--------|--------|--------|---------|---------|
| Dz | 75 | 80 | 90 | 100 | 120 | 130 | 140 | 160 | 190 | 210 | 240 | 265 | 320 | 375 | 440 |
| Do | 50 | 55 | 65 | 75 | 90 | 100 | 110 | 130 | 150 | 170 | 200 | 225 | 280 | 335 | 395 |
| dxn | 11 x 4 | 11 x 4 | 11 x 4 | 11 x 4 | 14 x 4 | 14 x 4 | 14 x 4 | 14 x 4 | 18 x 4 | 18 x 4 | 18 x 8 | 18 x 8 | 18 x 8 | 18 x 12 | 22 x 12 |
| g | 12 | 12 | 14 | 14 | 16 | 16 | 16 | 16 | 18 | 18 | 20 | 20 | 22 | 24 | 24 |

Kołnierze wg PN-EN 1092-1; PN 10

| | | | | | | | | | | | | | | | |
|-----|--------|--------|--------|--------|--------|--------|--------|--------|--------|--------|--------|--------|--------|---------|---------|
| Dz | 90 | 95 | 105 | 115 | 140 | 150 | 165 | 185 | 200 | 220 | 250 | 285 | 340 | 395 | 445 |
| Do | 60 | 65 | 75 | 85 | 100 | 110 | 125 | 145 | 160 | 180 | 210 | 240 | 295 | 350 | 400 |
| dxn | 14 x 4 | 14 x 4 | 14 x 4 | 14 x 4 | 18 x 4 | 18 x 4 | 18 x 4 | 18 x 8 | 18 x 8 | 18 x 8 | 18 x 8 | 22 x 8 | 22 x 8 | 22 x 12 | 22 x 12 |
| g | 14 | 14 | 16 | 16 | 18 | 18 | 20 | 20 | 20 | 22 | 22 | 24 | 24 | 26 | 26 |

Kołnierze wg PN-EN 1092-1; PN 16

| | | | | | | | | | | | | | | | |
|-----|--------|--------|--------|--------|--------|--------|--------|--------|--------|--------|--------|--------|---------|---------|---------|
| Dz | 90 | 95 | 105 | 115 | 140 | 150 | 165 | 185 | 200 | 220 | 250 | 285 | 340 | 405 | 460 |
| Do | 60 | 65 | 75 | 85 | 100 | 110 | 125 | 145 | 160 | 180 | 210 | 240 | 295 | 355 | 410 |
| dxn | 14 x 4 | 14 x 4 | 14 x 4 | 14 x 4 | 18 x 4 | 18 x 4 | 18 x 4 | 18 x 8 | 18 x 8 | 18 x 8 | 18 x 8 | 22 x 8 | 22 x 12 | 26 x 12 | 26 x 12 |
| g | 14 | 14 | 16 | 16 | 18 | 18 | 20 | 20 | 20 | 22 | 22 | 24 | 26 | 29 | 32 |

Kołnierze wg PN-EN 1092-1; PN 25

| | | | | | | | | | | | | | | | |
|-----|--------|--------|--------|--------|--------|--------|--------|--------|--------|--------|--------|--------|---------|---------|---------|
| Dz | 90 | 95 | 105 | 115 | 140 | 150 | 165 | 185 | 200 | 235 | 270 | 300 | 360 | 425 | 485 |
| Do | 60 | 65 | 75 | 85 | 100 | 110 | 125 | 145 | 160 | 190 | 220 | 250 | 310 | 370 | 430 |
| dxn | 14 x 4 | 14 x 4 | 14 x 4 | 14 x 4 | 18 x 4 | 18 x 4 | 18 x 4 | 18 x 8 | 18 x 8 | 22 x 8 | 26 x 8 | 26 x 8 | 26 x 12 | 30 x 12 | 30 x 16 |
| g | 14 | 14 | 16 | 16 | 18 | 18 | 20 | 22 | 24 | 26 | 28 | 30 | 32 | 35 | 38 |

Kołnierze wg PN-EN 1092-1; PN 40

| | | | | | | | | | | | | | | | |
|-----|--------|--------|--------|--------|--------|--------|--------|--------|--------|--------|--------|--------|---------|---------|---------|
| Dz | 90 | 95 | 105 | 115 | 140 | 150 | 165 | 185 | 200 | 235 | 270 | 300 | 375 | 450 | 515 |
| Do | 60 | 65 | 75 | 85 | 100 | 110 | 125 | 145 | 160 | 190 | 220 | 250 | 320 | 385 | 450 |
| dxn | 14 x 4 | 14 x 4 | 14 x 4 | 14 x 4 | 18 x 4 | 18 x 4 | 18 x 4 | 18 x 8 | 18 x 8 | 22 x 8 | 26 x 8 | 26 x 8 | 30 x 12 | 33 x 12 | 33 x 16 |
| g | 14 | 14 | 16 | 16 | 18 | 18 | 20 | 22 | 24 | 26 | 28 | 30 | 36 | 42 | 52 |

Kołnierze wg PN-EN 1092-1; PN 63

| | | | | | | | | | | | | | | | |
|-----|--------|--------|--------|--------|--------|--------|--------|--------|--------|--------|--------|--------|---------|---------|---------|
| Dz | 100 | 105 | 130 | 140 | 155 | 170 | 180 | 205 | 215 | 250 | 295 | 345 | 415 | 470 | 530 |
| Do | 70 | 75 | 90 | 100 | 110 | 125 | 135 | 160 | 170 | 200 | 240 | 280 | 345 | 400 | 460 |
| dxn | 14 x 4 | 14 x 4 | 18 x 4 | 18 x 4 | 22 x 4 | 22 x 4 | 22 x 4 | 22 x 8 | 22 x 8 | 26 x 8 | 30 x 8 | 33 x 8 | 36 x 12 | 36 x 12 | 36 x 16 |
| g | 20 | 20 | 22 | 24 | 24 | 26 | 26 | 26 | 30 | 32 | 34 | 36 | 48 | 55 | 65 |

Kołnierze wg PN-EN 1092-1; PN 100

| | | | | | | | | | | | | | | | |
|-----|--------|--------|--------|--------|--------|--------|--------|--------|--------|--------|--------|---------|---------|---------|---------|
| Dz | 100 | 105 | 130 | 140 | 155 | 170 | 195 | 220 | 230 | 265 | 315 | 355 | 430 | 505 | 585 |
| Do | 70 | 75 | 90 | 100 | 110 | 125 | 145 | 170 | 180 | 210 | 250 | 290 | 360 | 430 | 500 |
| dxn | 14 x 4 | 14 x 4 | 18 x 4 | 18 x 4 | 22 x 4 | 22 x 4 | 26 x 4 | 26 x 8 | 26 x 8 | 30 x 8 | 33 x 8 | 33 x 12 | 36 x 12 | 39 x 12 | 42 x 16 |
| g | 20 | 20 | 22 | 24 | 24 | 26 | 28 | 30 | 34 | 36 | 42 | 48 | 60 | 72 | 84 |

Istnieje możliwość wykonania kołnierzy w CLASS 150÷600