

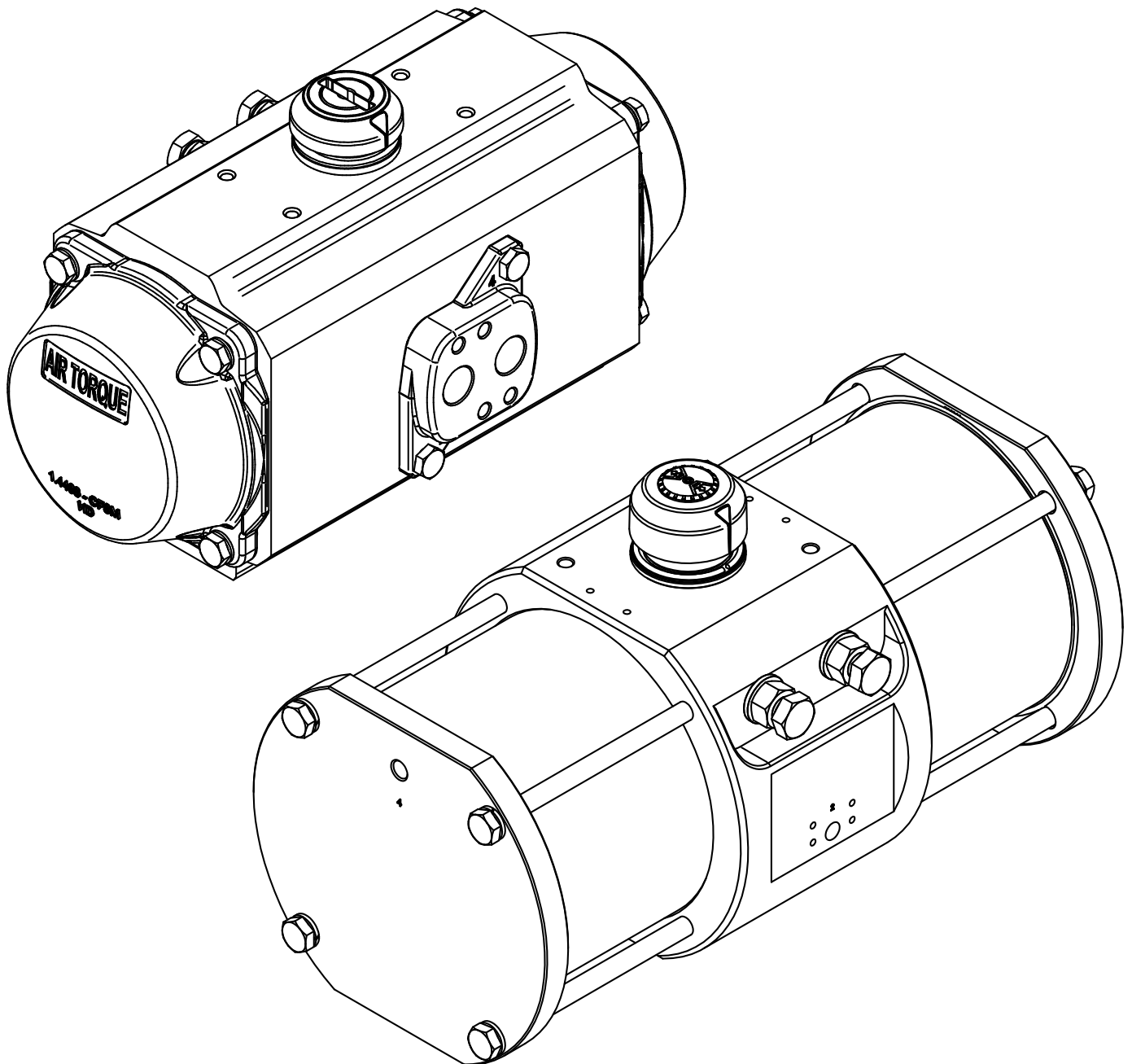

AIR TORQUE[®]

INSTALLATION, MAINTENANCE AND OPERATING INSTRUCTION MANUAL FOR FORGED STAINLESS STEEL ACTUATORS "S" Series

For AIR TORQUE ACTUATORS Model/Type:
 "SS AT054U" → "SS AT654"
 Double acting "D" and Spring return "S"
 "0°" → "90° Stroke"



CONTENTS

1) GENERAL	pag.	3
2) WARNING	pag.	3
3) WORKING CONDITIONS AND TECHNICAL DATA	pag.	3
4) OPERATING FUNCTION AND DIRECTION OF ROTATION	pag.	4
5) INSTALLATION INSTRUCTIONS	pag.	4
6) MAINTENANCE INSTRUCTIONS	pag.	5
7) STORAGE INSTRUCTIONS	pag.	11
8) LIFTING AND HANDLING	pag.	11

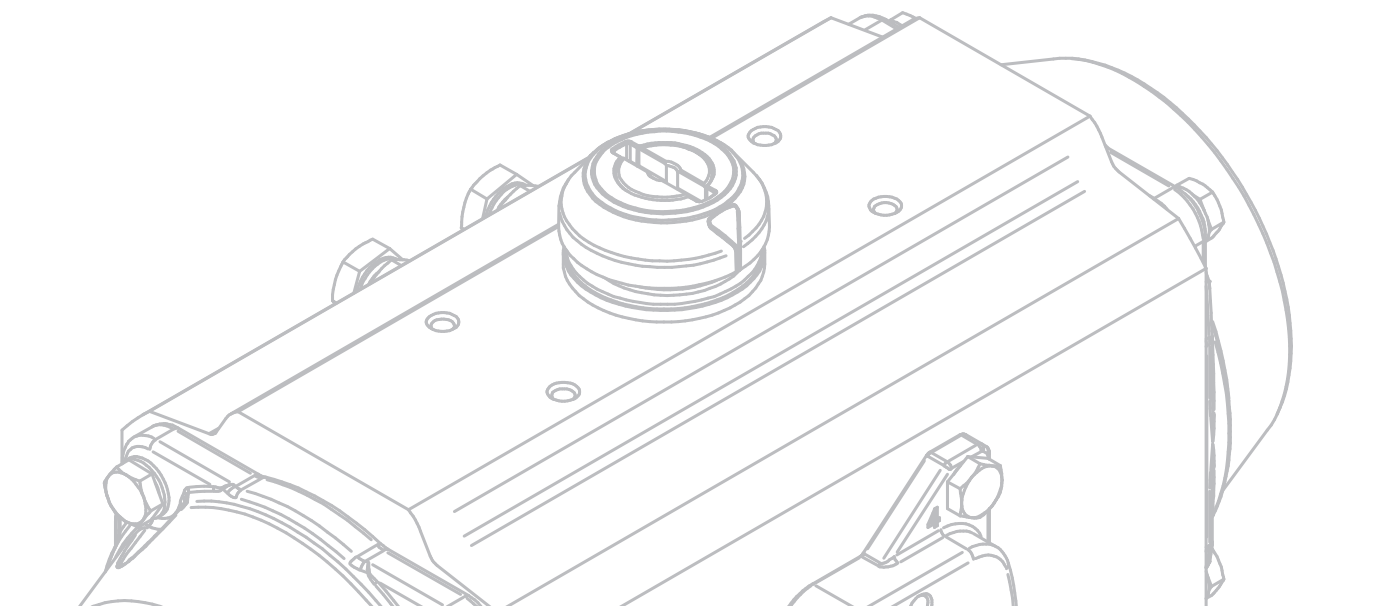

1) GENERAL

This instruction manual contains important information regarding the installation, operation, maintenance and storage for AIR TORQUE rack and pinion pneumatic actuators stainless steel series.

Please read these instructions carefully and keep them for future reference. It is important that the use and maintenance of the actuator is made only by properly trained personnel.

2) WARNING

- Do not operate the actuator using inflammable, oxidizing, corrosive, explosive or unstable gases or liquids (use only not dangerous fluids - group 2 according to 2014/68/EU directive).

Moreover, for actuators installed in potentially explosive zones, make sure that the internal parts of the actuator do not come into contact with the external atmosphere.

- Referring to the Machinery Directive 2006/42/EC, the actuators can be classified as “PARTLY COMPLETED MACHINERY” (see the DECLARATION OF INCORPORATION).

Therefore the actuator can not put into service until the machinery and/or the system, where the actuator is incorporated, will be declared in compliance with the requirements of the Directive 2006/42/EC.

- Air Torque actuators are designed, produced and classified according to the ATEX Directive 2014/34/EU (see actuator label and safety instructions).

The use of the actuators in potential explosive atmosphere zones has to comply with the ATEX classification indicated on the actuator label and according to the ATEX safety instructions.

- The use, the installation and the maintenance of the Air Torque actuators must be made by adequately trained personnel.

For the use, installation and maintenance of Air Torque actuators it is recommended to comply to the safety notice and to use proper equipment to protect health and prevent accidents.

- It is important that the actuator is used only within the working limits indicated in the technical specifications.
- Do not operate the actuator over temperature limits: this could damage internal and external components (disassembly of spring return actuator may become dangerous).
- Do not operate the actuator over pressure limits: this could damage internal parts as well as cause damage to the housing and end-caps.
- Do not use the actuator in corrosive environments with incorrect protection: this could damage the internal and external parts.
- Do not disassemble individual spring cartridges, this may result in personal injury. If maintenance to springs is necessary, send them to AIR TORQUE.
- Close and disconnect all air supply lines and make sure that air connections are vented during maintenance and installation on valve.
- Do not disassemble the actuator or remove end caps while the actuator is pressurized.
- The FORGED STAINLESS STEEL actuators are designed to be used only on valves.

- Before installing the actuator onto the valve make sure that the rotation direction and the position indicator are in the correct position.

- In case the actuator is installed on a valve with a gearbox for emergency manual operation, make sure that the stroke of the gearbox does not exceed the stroke allowed by the actuator. **Caution: make sure that the gearbox stroke, both in closed and in opened position, is properly adjusted.**

If you exceed the stroke allowed by the actuator with the manual operation of the gearbox, you can cause severe damage to the adjustment screws, to the pistons and to the actuator itself.

3) WORKING CONDITIONS AND TECHNICAL DATA

- Operating media:

Dry or lubricated air or inert gases, provided that they are compatible with the actuator internal parts and lubricant. The operating media must have a dew point equal to – 20°C (-4°F) or at least 10°C below the ambient temperature. The maximum particle size contained into the operating media must not exceed 30 µm.

- Supply pressure:

The maximum supply pressure is 8 bar (116 Psi). For double acting and spring return actuators the working pressure is from 2.5 bar (36 Psi) to 8 bar (116 Psi).

- Operating temperature:

==> “**Standard**” actuators from -40°C (-40°F) to +80°C (+176°F)

==> Actuators for high temperature “**HT**” from -15°C (+5°F) to +150°C (+300°F)

==> Actuators for extreme low temperature “**LLT**” from -55°C (-67°F) to + 80°C (+176°F)

Caution: for low and high temperature service, special grease and special components are required.

Please contact AIR TORQUE. Working at high or low temperature can affect the life and the output torque of the actuator.

- Operating time (see technical data sheet):

Caution: the operating time depends on several factors such as supply pressure, supply system capacity (pipe diameter, flow capacity of pneumatic accessories), valve type, valve torque and figures, applied safety factor, cycle frequency, temperature, etc.

- Rotation and stroke adjustment (see technical data sheet):

For standard actuators (90° rotation) and 180° actuators (180° rotation). Stroke adjustment at 0°(closed pistons): +5°max/ - 5°. Stroke adjustment at 90° and 180°(open pistons): +5°/-5°max.

- Lubrication:

The actuators are factory lubricated for the life of the actuator in normal working conditions.

The standard lubricant type GSTD is suitable for use from -40°C (-40°F) to +80°C (+176°F).

For extreme low temperature (LLT) and high temperature (HT) service, special grease is required: please contact Air Torque.

- Construction: rack and pinion actuator design suitable for both indoor or outdoor installations.

- Protection and corrosion resistance:

The Air Torque “S” series stainless steel actuator are a corrosion resistant rack and pinion actuator particularly engineered for corrosive environments or sanitary.

- Actuator designation and marking (see technical data sheets):
The actuator type, size, operating pressure, output torque, direction of rotation, spring action, operating temperature and type of connections/interfaces are determined by designation.
- All AIR TORQUE actuators are supplied with an identification label showing the serial number and all necessary information on use, service, operation and product designation. Where applicable, the label indicates the classification according to ATEX Directive 2014/34/EU.

4) OPERATING FUNCTION AND DIRECTION OF ROTATION

The actuator is a pneumatic device for remote operation of industrial valves. The operation (90° or 180° rotation) may be activated by different methods:

- Direct mounting of solenoid valve (5/2 for double acting, 3/2 for spring return) to pressure connections 2 and 4, connected to supply and control lines.
 - Screwed connection (to pressure connections 2 and 4) with air lines from separate control cabinet.
- The standard rotation (when port 4 is pressurized or for spring action) is clockwise to close. When port 2 is pressurized, counter-clockwise rotation is obtained. Air Torque actuators can be supplied with different types of assembly/rotation direction depending on the type of required operation and/or installation, see technical data sheets.

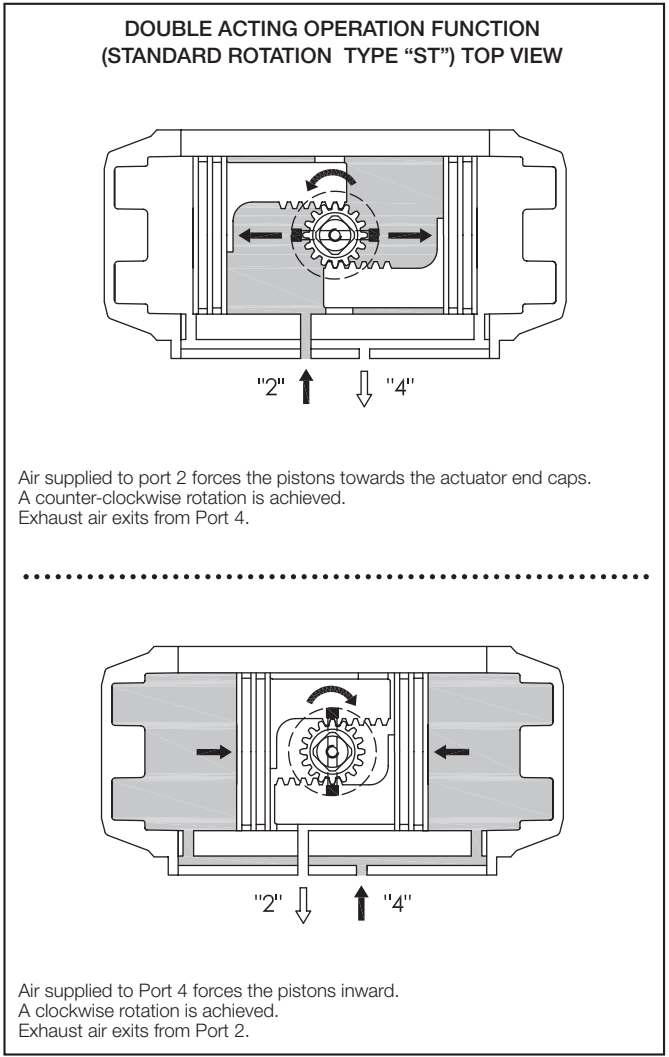
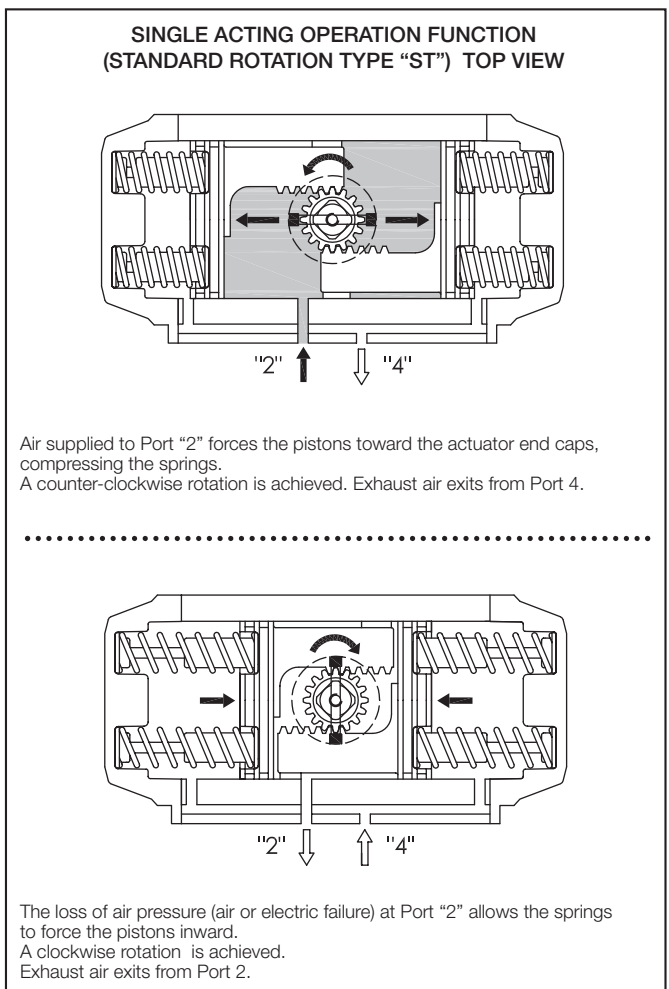

5) ACTUATOR INSTALLATION INSTRUCTIONS

The Air Torque actuator is a pneumatic device for the remote operation of industrial valves. The actuator will operate through 90° and 180° rotation permitting the opening and closing of many types of valves up to 180° rotation.

All the necessary technical information to install the actuator correctly and safely onto a valve i.e.:

Dimensions, Output torque, Supply pressure, Air volume, Stroke adjustment, Operating time, Operating temperature, Direction of rotation and Weight is stated clearly on the Actuator label, in the catalogue and technical data sheets. Please read all technical information before proceeding with the actuator installation.

⚠ 5.1) Important safety notice!

- For safety reasons, the actuator must not be pressurized at any time during installation as injury may result.
- The utmost cleanliness is required during air supply connection to the actuator i.e. the connecting pipe thread, fittings and seals must be clean and dirt-free.
- When fitting accessories onto the actuators, assemble them in such a way that the emergency control of the solenoid valve and the top of the drive shaft are easily accessible, should emergency manual operations be required.
- Before fitting onto the valve, make sure that the actuator/valve are correctly orientated, depending upon which direction of rotation is required.
- For spring return actuators, avoid that dangerous and/or corrosive substances in the working environment enter into the external chambers by using adequate filters and/or solenoid valves.

- Remove plugs from actuator air connections during installation and operation. Protect the air connections of actuators not being used immediately.

5.2) Interfaces for actuator control and connections, figure A:

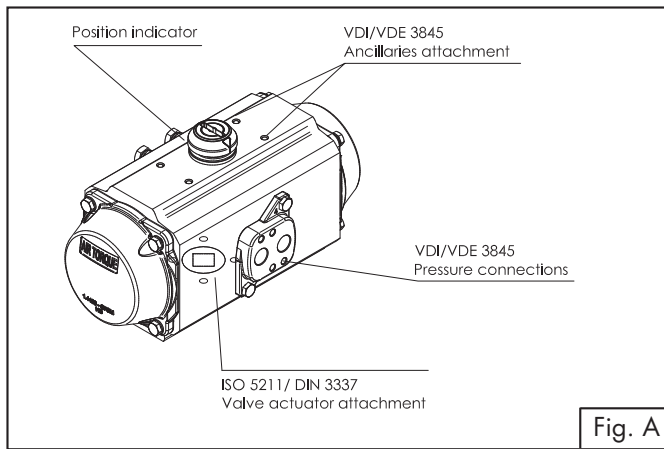

5.3) Assembly of accessories: solenoid valves and switchboxes, figure B:

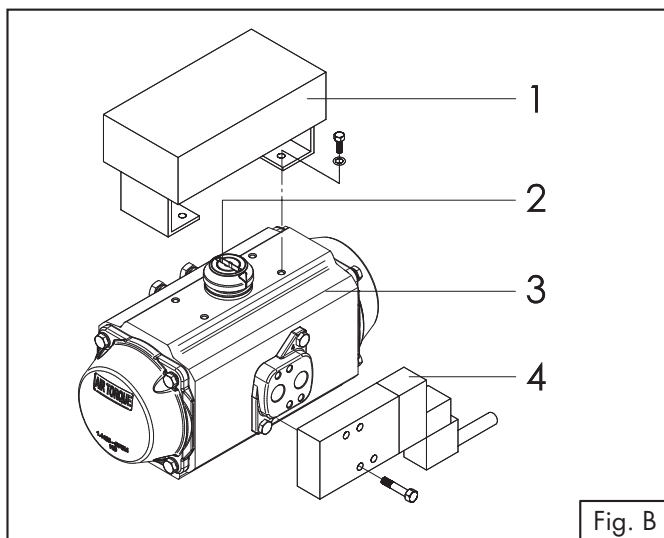

- Solenoid valve mounting:**
Before mounting a solenoid valve, ensure that the actuator is in its normal position (closed position) with pistons inwards. For standard rotation type “ST” (clockwise to close) assembly: the groove on the drive shaft or on the position indicator 2 must be horizontal to the longitudinal axis of the actuator in closed position. Fit the solenoid valve 4 onto the actuator 3 using the provided screws (max. tightening torque see table).
- Switchbox mounting:**
Fit the switchbox and bracket 1 onto the actuator 3 using four provided screws (max. tightening torque see table).

5.4) Assembly of valve figure C:

Before installing the actuator onto a valve, verify that the maximum transmissible torque for available ISO Flange and drive shaft connection is not exceeded according to ISO 5211 considering: the maximum actuator output torque, the maximum air supply pressure and the maximum valve torque.

Before proceeding with the assembly of the actuator onto the valve, be sure that the actuator operates in the desired direction of rotation when pressurised and both actuator/valve are in the correct position.

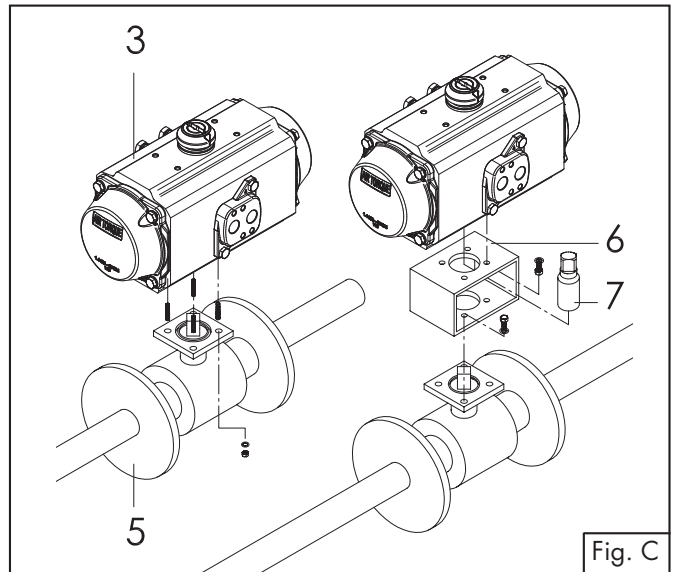

Important: when using a spring return actuator for a fail safe operation, ensure that when air or electricity failure occurs the direction of rotation is correct for your application.

Fit the actuator 3 onto the valve 5. It is possible to assemble the valve onto the actuator in two ways:

- Direct-mount: fit the stem of the valve 5 directly into the female connection of the actuator 3 and bolt together through the valve ISO pad (max. tightening torque see table).
- Bracket-mount: mounting with a bracket 6 and coupling 7, the bracket is bolted to the actuator / valve to join them together and the coupling is used to connect the actuator output drive to the valve stem (max. tightening torque see table).

	Nm	
	A	B
M5	5 ÷ 6	4 ÷ 5
M6	10 ÷ 11	7 ÷ 8
M8	23 ÷ 25	18 ÷ 20
M10	48 ÷ 52	34 ÷ 36
M12	82 ÷ 86	60 ÷ 64
M14	132 ÷ 138	96 ÷ 102
M16	200 ÷ 210	150 ÷ 160
M20	390 ÷ 410	290 ÷ 310
M24	675 ÷ 705	500 ÷ 530
M30 (A.. 50)	620 ÷ 650	470 ÷ 500
M30 (A.. 70)	1340 ÷ 1400	1000 ÷ 1050

Tightening torque table for DRY (A) and LUBRICATED (B) condition.

6) MAINTENANCE INSTRUCTION

With the information given below, AIR TORQUE provides the end user with all the required information necessary for maintenance. Under normal conditions, the actuator requires only periodic observation to ensure proper operation. Maintenance (disassembly, maintenance and rebuilding) of AIR TORQUE actuators is allowed only to AIR TORQUE personnel or properly instructed personnel. In case of controversy the product guarantee will expire!

Spare kits for maintenance are available to replace all seals and bearings (soft parts indicated into the table), that may be necessary between 300.000 and 1.000.000 cycles depending on operating and environmental conditions and actuator size.

6.1) DRAWING WITH ITEMIZED COMPONENTS AND RECOMMENDED SPARE PARTS

MODEL SS AT054U → SS AT404

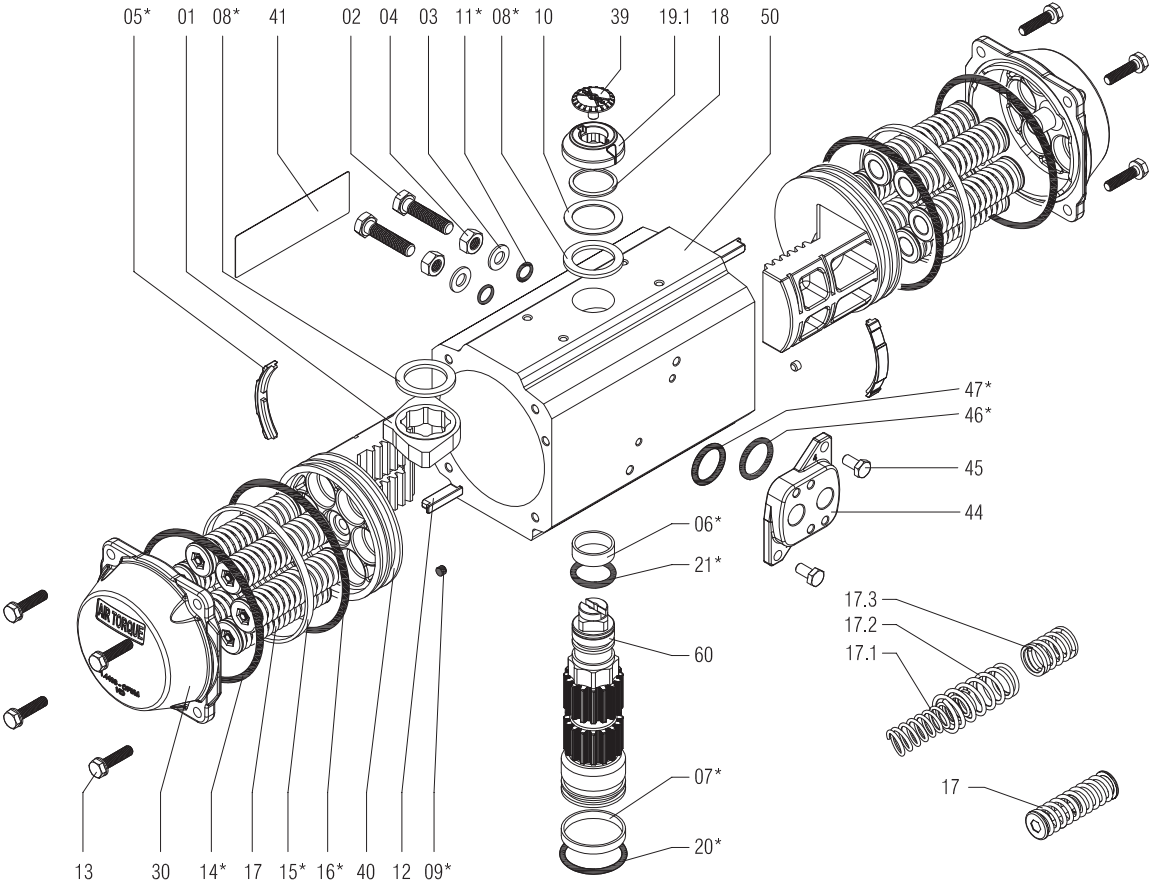

MODEL SS AT454 → SSAT654

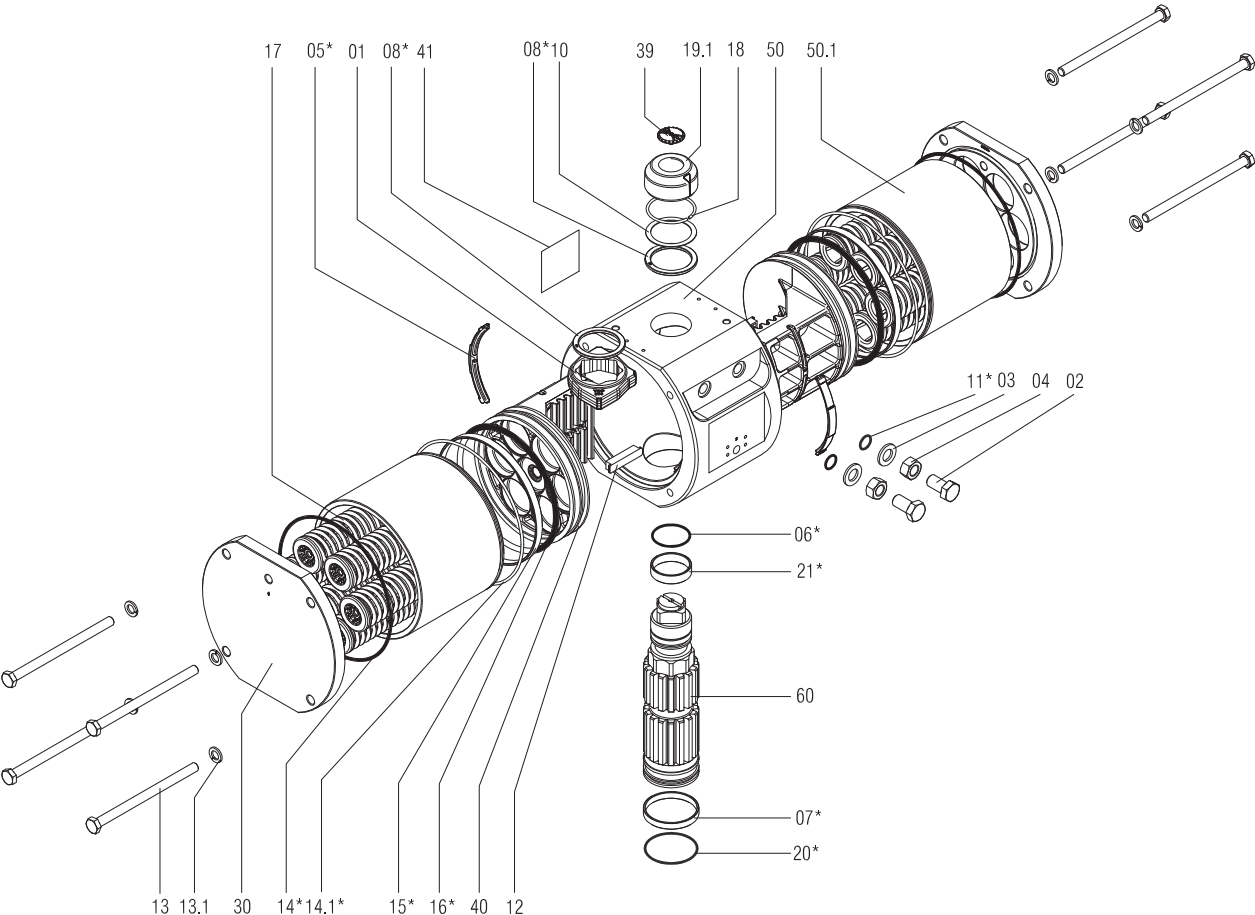

PART N°	UNIT Q.TY	NOTE	PART DESCRIPTION
01	1		OCTI-CAM (Stop arrangement)
02	2		STOP CAP SCREW
03	2		WASHER
04	2		NUT (Stop screw)
05*	4		BEARING (Piston back)
06*	1		BEARING (Pinion top)
07*	1		BEARING (Pinion bottom)
08*	2		THRUST BEARING (Pinion)
09*	2	NA for SS AT454 ÷ SS AT654	PLUG
10	1		THRUST WASHER (Pinion)
11*	2		"O" RING (Stop screw)
12	2		PISTON GUIDE
13	8		CAP SCREW (End cap)
13.1	8	for SS AT454 ÷ SS AT654	WASHER (Cap Screw)
14*	2		"O" RING (End cap)
14.1*	2	for SS AT454 ÷ SS AT654	"O" RING (Body Extensions)
15*	2		BEARING (Piston head)
16*	2		"O" RING (Piston)
17	min.5 / max.12		SPRING (Cartridge)
17.1	max. 4 for SS AT054U	NA for SS AT104 ÷ SS AT654	SPRING
17.2		NA for SS AT104 ÷ SS AT654	SPRING
17.3		NA for SS AT104 ÷ SS AT654	SPRING
18	1		SPRING CLIP (Pinion)
19.1	1	NA for SS AT054U ÷ SS AT104	POSITION INDICATOR
20*	1		"O" RING (Pinion bottom)
21*	1		"O" RING (Pinion top)
30	2		END CAP
39	1		CAP SCREW (Indicator)
40	2		PISTON
41	1		ACTUATOR IDENTIFICATION LABEL
44	1		NAMUR CONNECTION PLATE
45	2		CAP SCREW (Connection Plate)
46	1		"O" RING Port 2 (Connection Plate)
47	1		"O" RING Port 4 (Connection Plate)
50	1		BODY
50.1	2	for SS AT454 ÷ SS AT654	BODY EXTENSIONS
60	1		INTEGRAL DRIVE SHAFT

* Suggested SPARE PARTS for maintenance

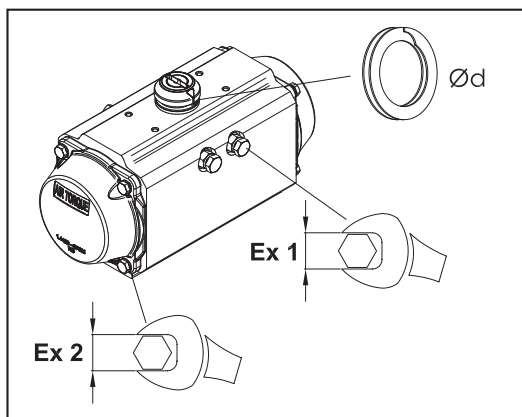

Model	Ex1 mm	Ex2 mm	d mm
SS AT054U	10	8	14
SS AT104	10	10	16
SS AT204	13	10	22
SS AT254	13	10	25
SS AT304	17	13	26
SS AT404	19	17	38
SS AT454	22	17	45
SS AT554	24	19	52
SS AT654	30	24	68

6.2) DISASSEMBLY

When disassembly of actuator is required for maintenance, firstly remove the actuator from the valve. Before performing any disassembly operations it is important to verify that the actuator is not pressurised.

Always use caution and double check that the ports 2 and 4 are vented and are free from any accessory and/or device. When the actuator is a spring return unit, make sure that the actuator is in the failed position and with pistons completely inwards before disassembling.

A) Removal of position indicator and graduated ring (Part N° 19,39,19.1), figure 01:

- Remove cap screw (39) if fitted.
- Lift position indicator (19 or 19.1) off shaft, it may be necessary to pry gently with a screwdriver.

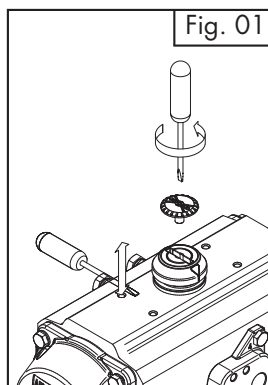

B) Removal of stop cap screws (Part N° 02), figure 02:

- Remove both stop cap screws together with nut (04) and washer (03).
- Remove stop screw o-rings (11) and discard if replacing all soft parts.

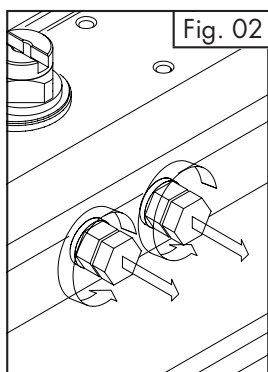

C) End caps disassembly (Part N° 30), figure 03/03B:

- End caps disassembly for spring return actuators (disassemble one end cap at a time).

Unscrew the end cap bolts (13) in the sequence shown in figure 03, until the end-caps are free from springs force (for SS AT054U 20-23 turns of the screws, for SS AT104 to SS AT654 4-5 turns of the screws).

Then completely unscrew the screws and remove the end-cap and the springs.

If there is still force on the end-caps after unscrewing as indicated above, this may indicate that spring cartridge is damaged or that the pistons are not completely closed, so any further disassembly should be discontinued. Further disassembly of the end caps may result in injury.

- End caps disassembly for double acting actuators (disassemble one end cap at a time)

Unscrew the end cap bolts (13) in the sequence shown in figure 03, until the screws are completely unscrewed and the end caps are free.

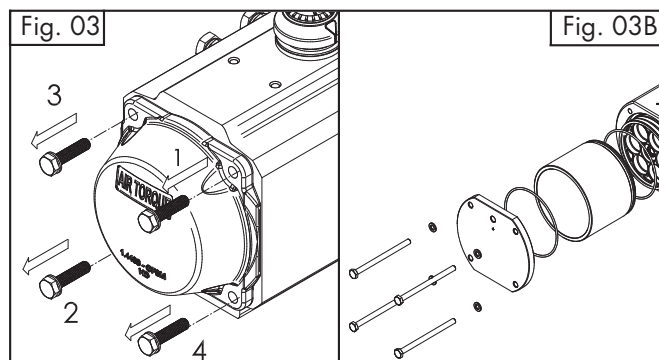

- Remove the o-rings (14) using a screwdriver. Discard soft parts if replacing.
- For actuator's sizes SS AT450, SS AT550 and SS AT650, after removing the end cap, you need to remove the body extension (picture 03B).
- Only for actuators with adjustment 50% or 100%, remove the nut 04R, the washers 03R and o-rings 11R and discard soft parts if replacing.

D) Pistons disassembly (Part N° 40), figure 04:

- Holding the body (50) in a vice or similar device, rotate the drive shaft (60) until the pistons (40) are released. Caution: air pressure should not be used to remove the pistons from the body.
- Remove o-rings (16) using a screwdriver. Remove the piston back (05) and piston head (15) bearings.
- Discard bearings when replacing all soft components.

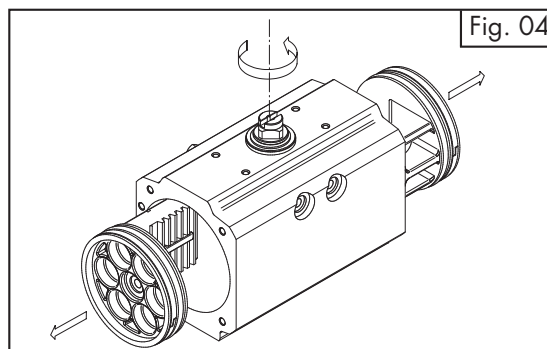

E) Drive shaft disassembly (Part N° 60), figure 05:

- If necessary, remove the spiral rings (18) using screwdriver for spiral rings, remove the thrust washer (10) and the external thrust bearing (08). Apply downward force to top of drive shaft (60), until it is partially out of the bottom of the body when it is possible to remove the internal thrust bearing (08) and the octi-cam (01), then push the pinion (60) completely out of the body. If pinion is not easily removed, gently tap the top of the shaft with a plastic hammer.

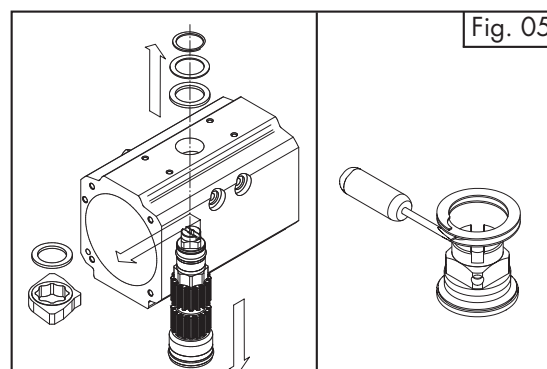

IMAT SS-E

- Remove top (06) and bottom (07) pinion bearings and top (20) and bottom (21) pinion o-rings.
- Discard bearings (06) and (07), internal and external thrust washer (08) and o-rings (20) and (21) if replacing the soft components.

All the components disassembled and not replaced will have to be cleaned and inspected for wear and before reassembly, if necessary, also replace the plugs (09).

6.3) ASSEMBLY:

Prior to assembly, ensure that:

- all the components are perfectly clean and in good condition.
 - the spare parts and the lubricant used are suitable for the operating temperature of the actuator (see Air Torque technical data sheets).
 - Note: The lubricants suitable for the various operating temperatures (Standard, HT and LLT actuators) are available in Air Torque.
- Only for "standard" actuators, for temperature from -40°C (-40°F) to $+80^{\circ}\text{C}$ ($+176^{\circ}\text{F}$), it is possible to use lubricant Dow Corning type Molykote® G-2003.

A) Drive shaft assembly (Part N° 60), figures 06, 07 and 07A:

- Install top (06) and bottom (07) bearings, grease and insert the bottom (20) and top (21) pinion o-rings onto the shaft.
- Grease the outside surface of the drive shaft as shown in figure 06.

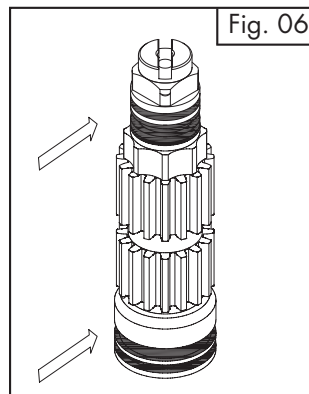

- Insert partially the drive shaft (60) in the body (50), install octi-cam (01) in the correct position (for standard assembly or for lock-out) as shown in figures 07 and 07A, related to the bottom and top of the drive shaft and the rotation of the actuator when energised. Install the internal thrust bearing (08). Insert completely the drive shaft in the body.

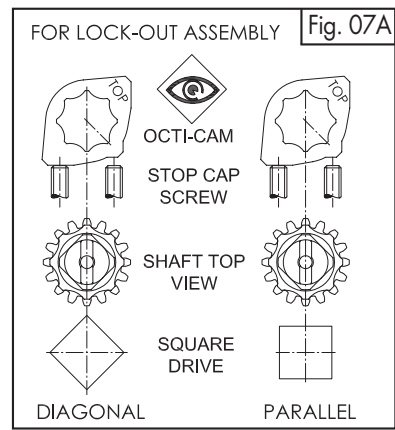
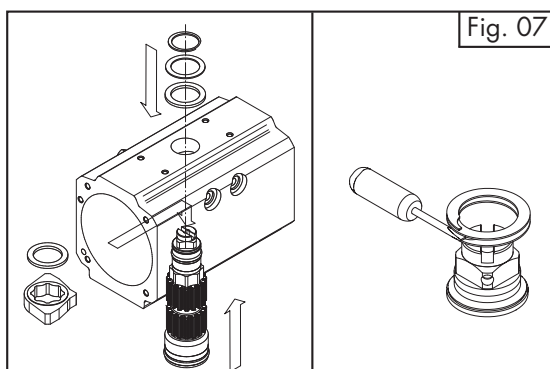

- Fit external thrust bearing (08), thrust washer (10) and then external spiral rings (18) using snap screwdriver.

B) Pistons assembly (Part N° 40), figures 08, 09, 10 and 11:

- Grease and install o-rings (16), piston back (05) and piston head (15) bearings.
- Grease the internal surface of the body (50) and the piston (40) rack teeth.
- Insert the female connection of the drive shaft (60) in a properly fixed coupling.
- Ensure that the octi-cam is in the right position as shown in figure 09.

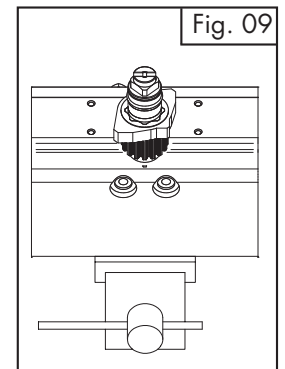
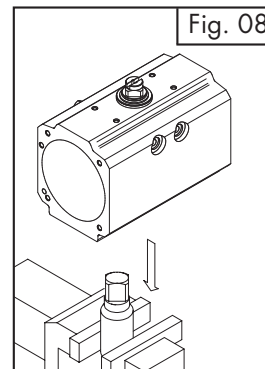

- For standard rotation assembly type "ST" (clockwise to close), rotate the body (50) about 40° - 45° clockwise from top view, as shown in figure 10.

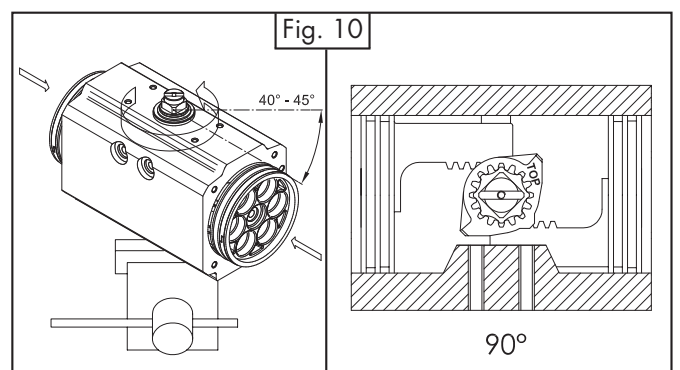

- Insert and press the two pistons (40) simultaneously inside the body (50) until the pistons are engaged, then rotate the body anticlockwise from top view until the stroke is completed.
- Ensure that with pistons completely closed, the rotation obtained referred to the axis of the body is about over 0° for models SS AT054U→SS AT654 and that the dimension "A" on both sides is the same as shown in figure 11.

Please note: for the actuators models SS AT454, SS AT554 and SS AT654, even if the pistons are fully inserted into the body 50, they will protrude from the body as shown in Fig. 10. Make sure that the protrusion of the pistons is the same from both sides and that the position of the octi-cam is as indicated in figure 10/11.

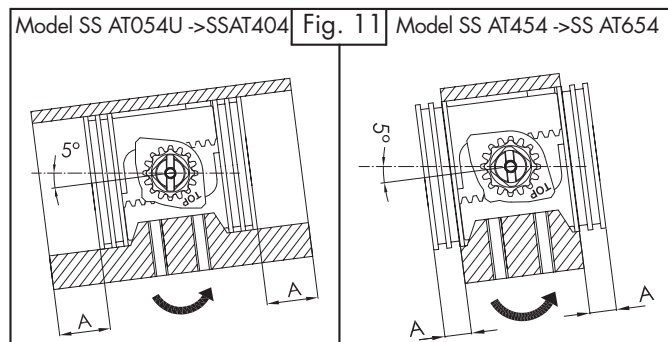

SPRING SET CONFIGURATION

SS AT054U configuration:

Spring Set	Side B		Side A	
	SS AT054U Internal Spring type	SS AT054U External Spring type	SS AT054U Internal Spring type	SS AT054U External Spring type
S1	1 (green)	-----	-----	2 (black)
S2	-----	2 (black)	-----	2 (black)
S3	-----	2 (black)	-----	3 (red)
S4	-----	3 (red)	-----	3 (red)
S5	-----	3 (red)	1 (green)	2 (black)
S6	1 (green)	2 (black)	1 (green)	2 (black)
S7	1 (green)	2 (black)	1 (green)	3 (red)
S8	1 (green)	3 (red)	1 (green)	3 (red)

C) End cap (Part N° 30) assembly, figures 12, 13 and 14/14B:

- Assemble one end cap at a time.
- Lubricate the body.
- For spring return actuators, insert the springs in each end cap according to the desired configuration, as shown in figure 12 and related tables. For models SS AT104→SS AT654 insert spring cartridges as shown in figure 13.

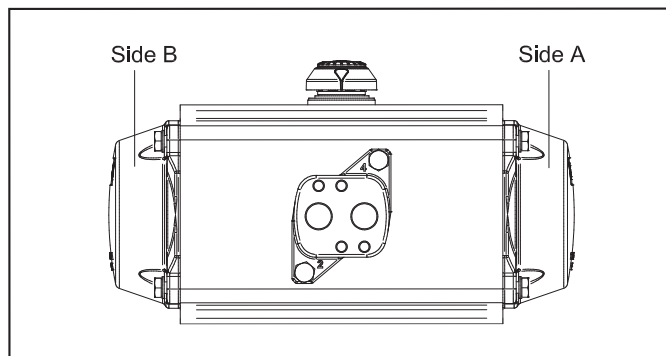
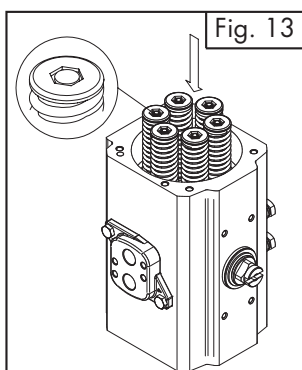
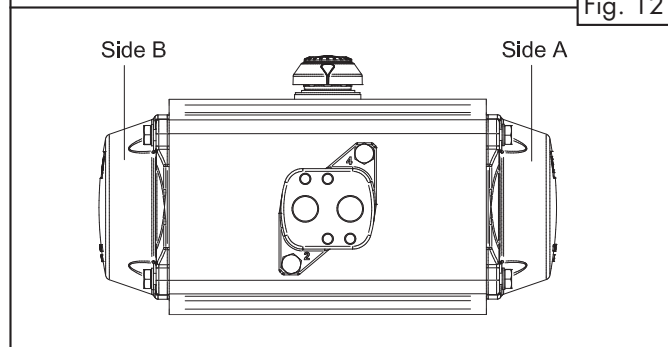
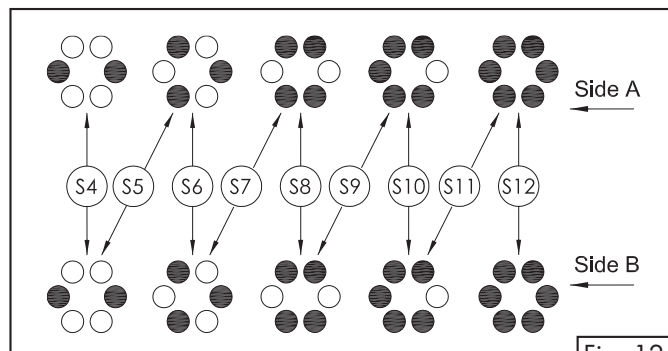

- Fit end cap o-ring seal (14) into the groove on both end caps.

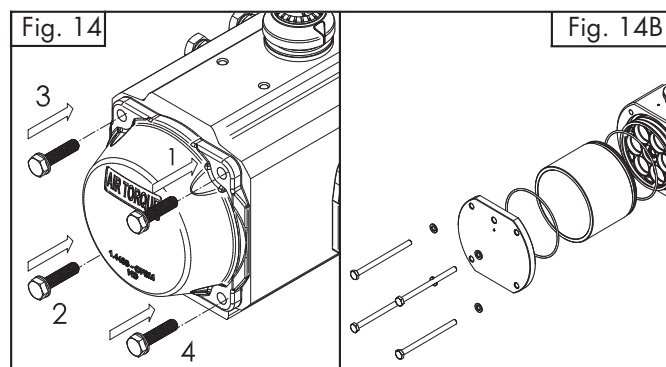

- Fit end caps onto the body (50), verifying that the o-ring remains in the groove.
- For actuator's sizes SS AT450, SS AT550 and SS AT650, mount the body extension and then the end cap on the sides and then proceed with the mounting of the body extension and of the end cap on the other side.
- Only for actuators with 50% or 100% stroke adjustment, ensure that the adjustment screws 221G/222G are completely screwed into the end-cap.
- Insert the cap screws (13) and tighten each only partially. Complete tightening by making 1-2 turns for each screw in the sequence shown in figure 14 until tightening is completed. See the table for screw tightening torque.

D) Assembly of stop cap screws (Part 02) and stroke adjustment for models SS AT054U→SS AT654, figures 15 and 16:

- Insert on both stop screws (02) the nut (04), the washer (03) and the o-ring (11).
- Fit the stop cap screws (02) in the body.
- Stroke adjustment for actuators with standard type “ST” rotation / assembly (clockwise to close).

Stroke adjustment in close position: with the actuator in close position 0°, screw or unscrew the right (from top view) stop cap screw until the desired stop position is achieved. Then tighten the stop adjustment nut (04) to lock it in place.

Stroke adjustment in open position: with the actuator in open position 90°, screw or unscrew the left (from top view) stop cap screw until the desired stop position is achieved. Then tighten the stop adjustment nut (04) to lock it in place.

For spring return actuators, it could be necessary to make rotation tests to verify the correct stroke adjustment in open position.

- Only for actuators with adjustment 50% or 100%, fit on end-cap adjustment screws 221G/222G the o-rings 11R, the washers 03R and the nuts 04R. To adjust the stroke in open position: with the actuator in partially or totally open position, screw or unscrew the end-cap adjustment screw 221G/222G until the desired position is achieved. It is important that the two end-cap adjustment screws are both in contact with the pistons. Then lock the nuts 04R.

7) STORAGE INSTRUCTIONS

If the actuator is not for immediate use, the following precaution must be taken for storage:

- Store the actuator in a clean and dry environment and at temperature between -20°C (-4°F) and +40°C (+104°F).
- It is recommended that the actuator be stored in its original box.
- Do not remove the plastic plugs on air supply ports.

8) LIFTING and HANDLING

It is recommended to lift the actuators with proper, adequate and permitted systems in relation to the actuator weight and by following the ruling laws in terms of safety and health protection. The weight of the actuators is indicated on the Air Torque catalogue and on the related technical data-sheets.

During the lifting and the handling of the actuators, it is recommended to avoid clashes and/or accidental falls in order to avoid irreparable damages to the actuators and to compromise the functionality.

Contact Air Torque for any information and technical data-sheets.

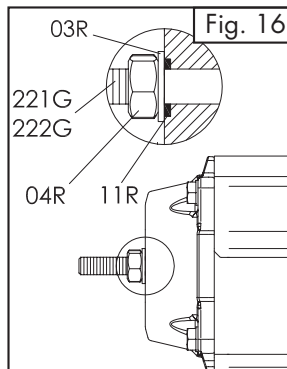
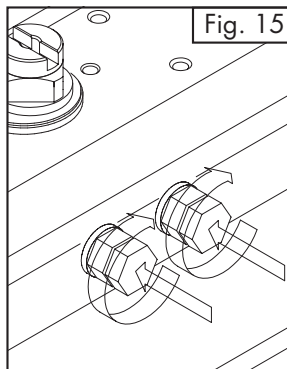

E) Assembly position indicator (Part N° 19.1), figures 18:

- Insert the indicator (19 or 19.1) making sure that it indicates the correct actuator position.
- Screw the indicator screw (39) if assembled.

