



aerospace
 climate control
 electromechanical
 filtration
 fluid & gas handling
 hydraulics
pneumatics
 process control
 sealing & shielding



Parker Global Air Preparation System

Catalog 0750-2 US



ENGINEERING YOUR SUCCESS.



PRZEDSTAWICIEL
 HANDLOWY

"ARMMASTER"

Biurow handlowe

Przedsiębiorstwo Handlowo-Usługowe
 Stanisław Zawieja
 98-200 Sieradz; ul. E. Orzeszkowej 3
 NIP: 827-108-05-12

98-200 Sieradz; ul. Jana Pawła II 59
 Tel. / fax (43) 822 32 36
 Tel. kom. 602 373 675
 www.armaster.com.pl



DECLARATION OF COMPLIANCE (ROHS)

European Directive 2002/95/EC - RoHS (**R**estriction of use of certain **H**azardous **S**ubstances in electrical and electronic equipment), restricts the use of the 6 substances below in the manufacture of specified electrical equipment.

| Substance | Concentration |
|-----------------------------------------------|----------------------------------------------------------------------------------------------------------------------------------------------------------------------------------------------------------------------------------------------------|
| LEAD: | Product containing lead and its compounds (except for application of lead as an alloying element by weight in steel up to 0.35%, in aluminum up to 0.4% and in copper alloys up to 4% and in Circuit Board solder) must not exceed 0.1% by weight. |
| MERCURY: | The concentration level must not exceed 0.1% by weight. |
| CADMIUM: | The concentration level must not exceed 0.01% by weight. |
| HEXAVALENT CHROMIUM: | This is a corrosive protective finish used on our product line. Where this finish is utilized the Chromate solution is Hexavalent (Chrome 6) free. |
| POLYBROMINATED BIPHENYLS (PBB): | The concentration level must not exceed 0.1% by weight. This substance is not known to be in any of our products. |
| POLYBROMINATED DIPHENYL ETHERS (PBDE): | The concentration level must not exceed 0.1% by weight. This substance is not known to be in any of our products. |

This information applies to product sold on or after 1st July, 2006

WARNING

FAILURE OR IMPROPER SELECTION OR IMPROPER USE OF THE PRODUCTS AND/OR SYSTEMS DESCRIBED HEREIN OR RELATED ITEMS CAN CAUSE DEATH, PERSONAL INJURY AND PROPERTY DAMAGE.

This document and other information from Parker Hannifin Corporation, its subsidiaries and authorized distributors provide product and/or system options for further investigation by users having technical expertise. It is important that you analyze all aspects of your application including consequences of any failure, and review the information concerning the product or system in the current product catalog. Due to the variety of operating conditions and applications for these products or systems, the user, through its own analysis and testing, is solely responsible for making the final selection of the products and systems and assuring that all performance, safety and warning requirements of the application are met.

The products described herein, including without limitation, product features, specifications, designs, availability and pricing, are subject to change by Parker Hannifin Corporation and its subsidiaries at any time without notice.

Offer of Sale

The items described in this document are hereby offered for sale by Parker Hannifin Corporation, its subsidiaries or its authorized distributors. This offer and its acceptance are governed by the provisions stated on the separate page of this document entitled "Offer of Sale".

Global Air Preparation System

Introduction 4-13

Compos

- P31 Mini Series 14
- P32 Compact Series 15
- P33 Standard Series 16
- Dimensions 17

Filters

- P31 Mini Series 18-19
- P32 Compact Series 20-21
- P33 Standard Series 22-23

Coalescing & Adsorber Filters

- P31 Mini Series 24-25
- P32 Compact Series 26-27
- P33 Standard Series 28-29

Regulators

- P31 Mini Series 30-31
- P31 Mini Common Port Regulator 32-33
- P32 Compact Series 34-35
- P32 Compact Common Port Regulator 36-37
- P33 Standard Series 38-39

Filter / Regulators

- P31 Mini Series 40-41
- P32 Compact Series 42-42
- P33 Standard Series 44-45

Lubricators

- P31 Mini Series 46-47
- P32 Compact Series 48-49
- P33 Standard Series 50-51

Proportional Regulators

- P31 Mini Series & P32 Compact Series 52-61

Combined Soft Start / Dump Valve 62-63

Dump Valve 64-65

Soft Start Valve 66-67

Solenoid Operators 68-69

Safety Lockout Valve 70

Modular Ball Valves 71

Manifold Blocks 72

Accessories

- P31 Mini Series 73
- P32 Compact Series 74
- P33 Standard Series 75
- Accessories Kits 76-78

Safety Guide 80-81

Offer of Sale 82





Parker Global Air Preparation System

Global.
Economical.
Modular.



*Performance you need,
wherever you need it.*

The comprehensive Global Air Preparation System is available in three body sizes with either BSPP, BSPT, or NPT to accommodate thread type requirements.

Full featured filters, regulators, filter/regulators, and lubricators are available with a wide range of standard options to meet air preparation needs.

Individual units can easily be assembled into various combinations, utilizing patented modular lightweight body connectors.

www.parker.com/globalfrl

Comprehensive Offering



P31 Mini Series
1/4" ports
40mm body width



P32 Compact Series
1/4", 3/8" and 1/2"
60mm body width



P33 Standard Series
1/2" and 3/4"
73mm body width



Filters

- 5 μ particulate, 1.0 μ and 0.01 μ coalescing, and adsorber available as standard
- Transparent or metal bowl with manual or auto float drains standard



Regulators

- Available as stand alone, common port and electronic proportional
- Both relieving and non-relieving versions available



Filter / Regulators

- Compact design for space savings
- Available with all the same standard options as the filters and regulators



Lubricators

- Proportional oil delivery over a wide range of air flows
- Fill under pressure



Combinations

- Compact design for space savings
- Easily assembled
- Many configurations available



Accessories





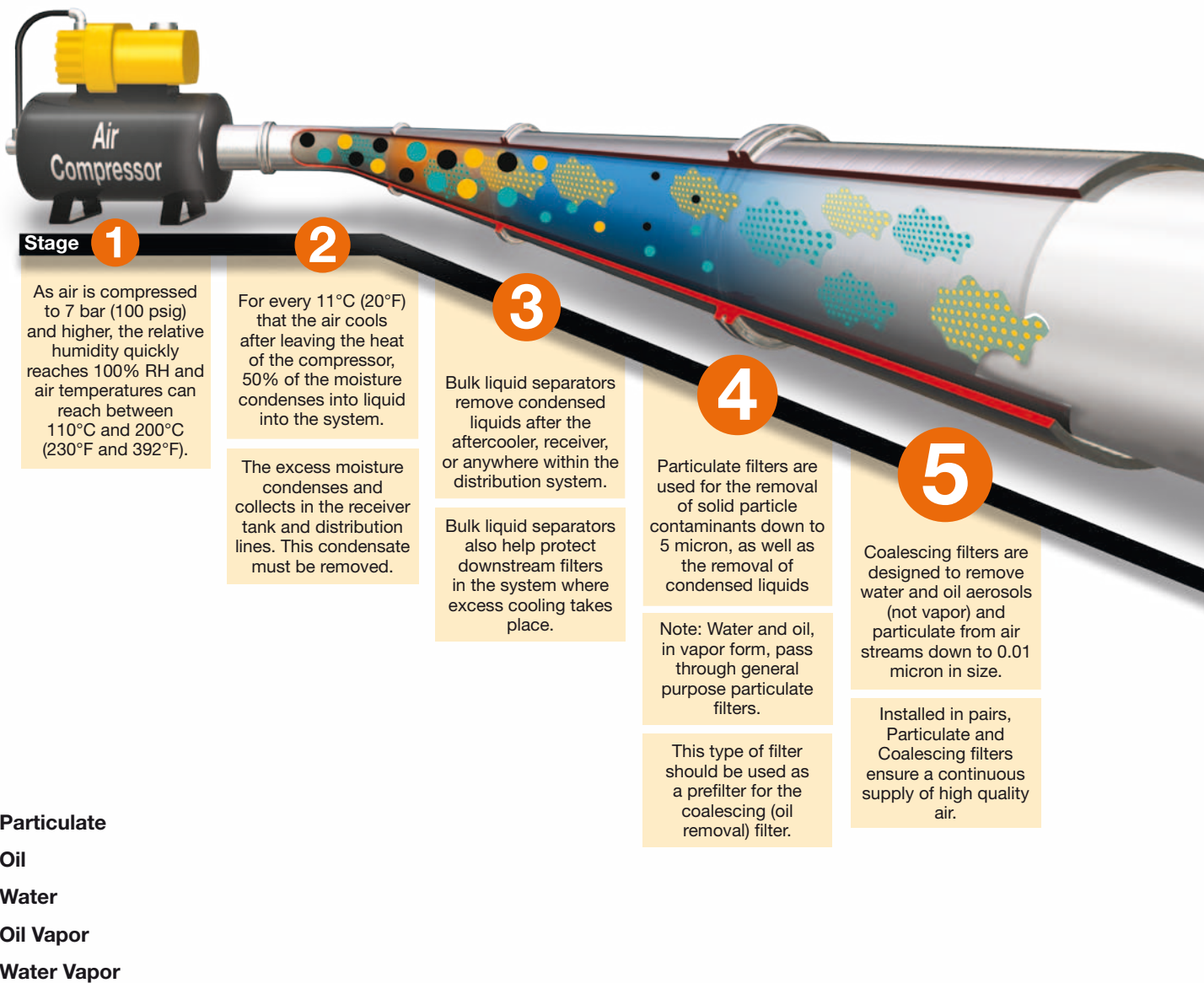

- Solenoid operated soft start, quick dump, and soft start/quick dump valves
- Manifold blocks
- Shut-off valves (both slide and ball type)
- Repair kits, gauges, etc.

Together we can power your application with clean, dry air

Fast cycle times, high product quality, and low downtime all require a clean, dry pneumatic system to function properly. Parker has what it takes to make sure pneumatic systems perform at their best.

Clean, dry pneumatic systems with Parker Global Air Preparation



| | | | | | | |
|-----------------------------------------------|-----------------------------------------------------------------------------------------------------------------------------------|--------------------------------------------------------------------------------------------------------------------|---------------------------------------------------------------------------------------|-------------------------------------------------------------------------------------|-------------------------------------------------------------------------------------------------------------------------|-------------------------------------------------------------------------------------|
| |  |  |  |  |  |  |
| Stages | 1 2 | 3 | 4 | 5 | 6 | 7 |
| Function | Air Compressor | Bulk Liquid Removal | Particulate Filtration | Coalescing Filtration | Air Dryers | Hydrocarbon Removal |
| Application | All pneumatic systems | Basic pneumatic systems | Basic pneumatic systems | Systems requiring highest quality air. | Systems requiring air with reduced moisture content | Systems requiring highest quality air for critical applications |
| Description | Air leaving the compressor room at 93°C (200°F) releases 95% of its moisture into the piping system when it cools to 38°C (100°F) | Removes bulk liquid contamination and protects filters where excess cooling takes place in the distribution piping | Removes solid particulates down to 5 micron, and the separation of bulk contaminants. | Removes liquid aerosols and submicron particulates (not vapor) down to 0.01 micron. | Removes water vapor from air stream. Dew point reduced down to 4°C (40°F) (refrigeration) or -40°C (-40°F) (desiccant). | Removal of odors and trace vapors for critical applications. |
| Parker Global Air Preparation Solution | Customer supplied | P3TF Bulk Liquid Separator | P31, P32, P33 Particulate Filter | P31, P32, P33 Coalescing Filter | PDRD Refrigeration Dryer P3TJ Regenerative Desiccant Dryer | P31, P32, P33 Activated Carbon (Adsorber) Filter |

Clean Dry Air

6

Refrigeration and desiccant dryers lower the air's dew point by removing water vapor, providing appropriately dry air for the downstream application.

7

Hydrocarbon and oil vapors are removed using filters utilizing activated carbon. Airborne hydrocarbons are often left over from the compressor oils.

A completely modular air preparation system

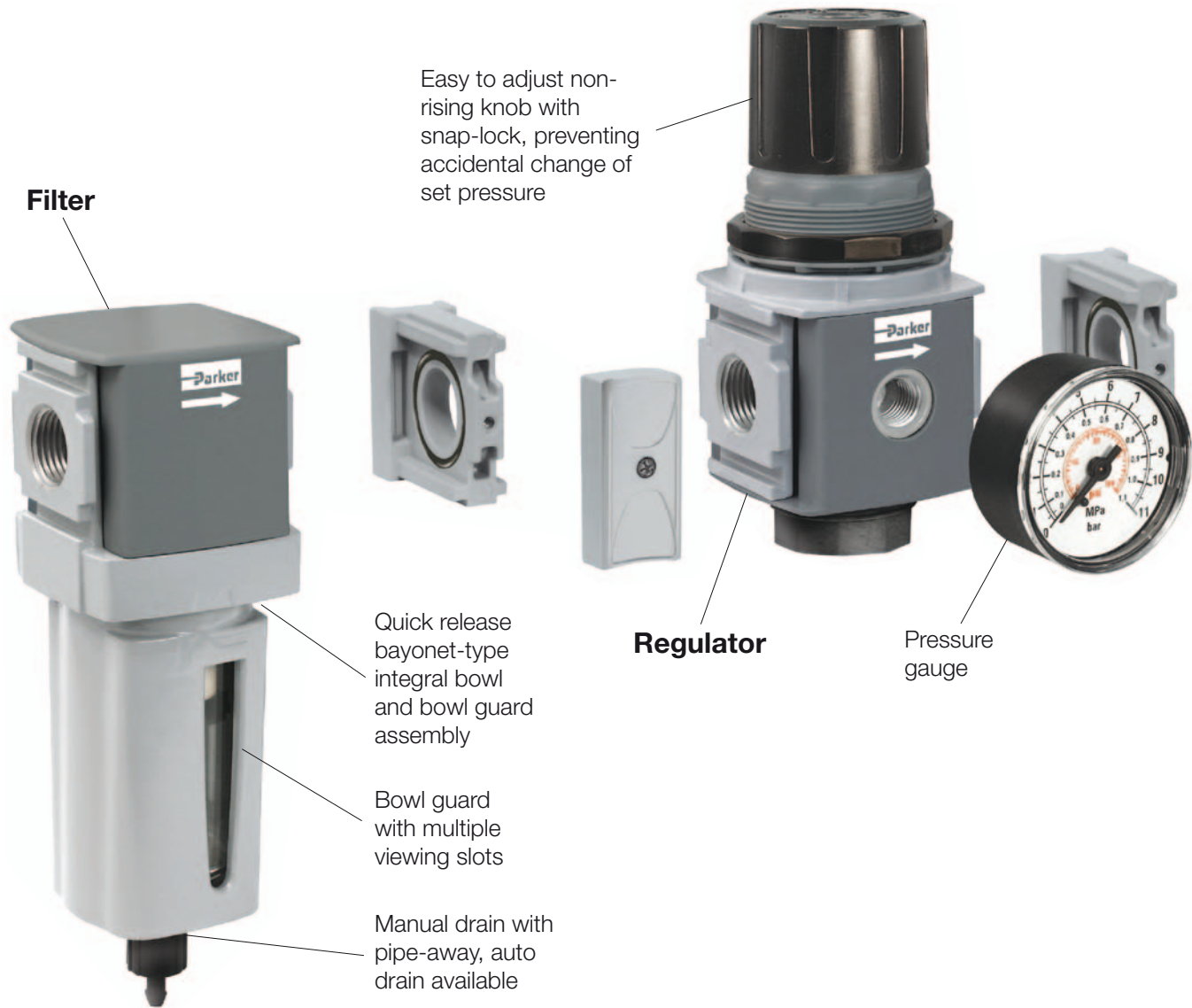

Electronic Proportional Regulator

- Electro-Pneumatic regulator
- Integrated systems control
- Accurate output pressure
- Micro parameter settings
- Selectable I/O parameters
- Quick, full flow exhaust
- LED display indicates output pressure
- No air consumption in steady state
- Multiple mounting options
- Protection to IP65



P31P Mini Series



P32P Compact Series

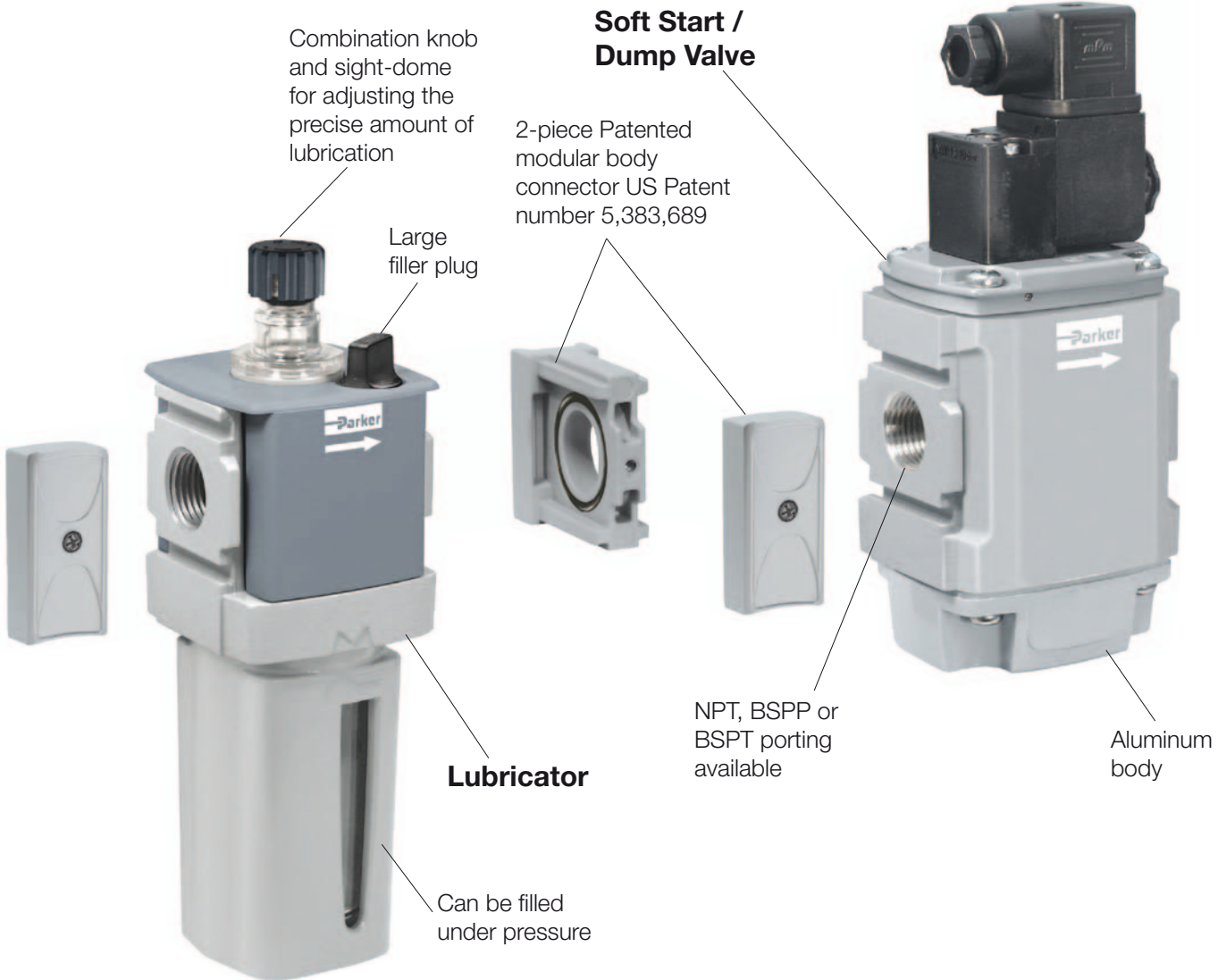

Common Port Manifold Regulators

- Multiple output pressures (P2, P3, P4, etc.) with common inlet (P1)
- Available in two sizes P31 and P32
- Balanced valve design for accurate pressure regulation
- Outlet pressure ports in front and rear of unit.
- Four spring ranges available



Air Preparation

P31 Mini Series

40mm body width
 1/4" Ported

| Flows up to: | dm ³ /s | (SCFM) |
|------------------|--------------------|--------|
| Filter | 12 | (25) |
| Coalescer | 2 | (4.2) |
| Regulator | 30 | (64) |
| Filter/Regulator | 14 | (30) |
| Lubricator | 13 | (28) |

Features:

- Space saving integral gauge
- Manifold style regulators available
- OSHA compliant shut-off valves
- Soft-Start & Quick Dump valves
- Electronic Proportional Regulator



P32 Compact Series

60mm body width
 1/4", 3/8", & 1/2" Ported

| Flows up to: | dm ³ /s | (SCFM) |
|------------------|--------------------|--------|
| Filter | 38 | (80) |
| Coalescer | 11 | (23) |
| Regulator | 67 | (142) |
| Filter/Regulator | 64 | (136) |
| Lubricator | 47 | (100) |

Features:

- Manifold style regulators available
- OSHA Compliant shut-off valves
- Soft-Start & Quick Dump valves
- Electronic Proportional Regulator



P33 Standard Series

73mm body width
 1/2" & 3/4" Ported

| Flows up to: | dm ³ /s | (SCFM) |
|------------------|--------------------|--------|
| Filter | 48 | (102) |
| Coalescer | 20 | (42) |
| Regulator | 100 | (212) |
| Filter/Regulator | 98 | (208) |
| Lubricator | 68 | (144) |

Features:

- OSHA Compliant shut-off valves
- Soft-Start & Quick Dump valves (Utilizes P32 size only)
- Electronic proportional regulator (Utilizes P32 size only)



Valves and Actuators

Mini Series Complimentary Products

The P31 Mini Series FRL's and accessories are well matched for use with these Parker valves and actuators.



Isys Micro



Moduflex Size 1

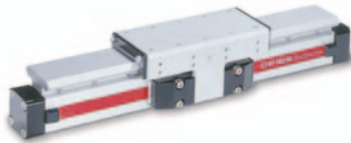

OSP-P



P1D



P1A

Compact Series Complimentary Products

The P32 Series FRL's & accessories are well matched for use with these Parker valves and actuators.



Isys Micro

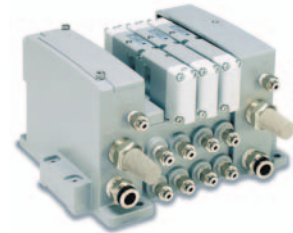

Isys HA / HB



P1D

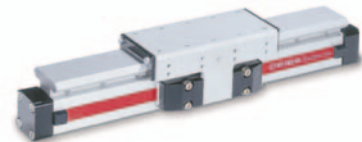

OSP-P

Standard Series Complimentary Products

The P33 Series FRL's & accessories are well matched for use with these Parker valves and actuators.

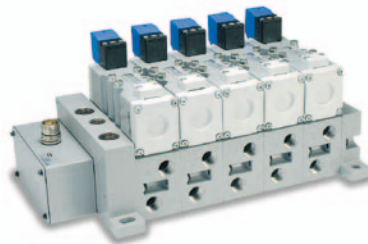

Isys Size 1

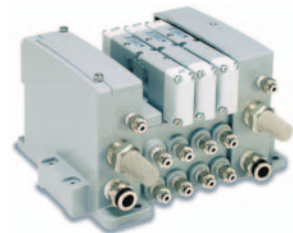

Isys HA / HB



P1D

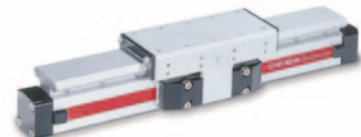

OSP-P

Complete Pneumatic System

Pressure Regulation

Accurate pressure regulation is important to control forces, speeds, torque, dispensing, processes, etc. Parker has a global solution to all of your pressure regulation needs, with support around the world.



| Function | Single | Common Port Manifold | Electronic Proportional |
|-----------------------------------------------|-------------------------------------------------------------|-------------------------------------------------------------------------------------------------------------------------------|---------------------------------------------------------------------------------------------------------------------------------------------------------------------|
| Description | For pneumatic systems requiring single pressure regulation. | For pneumatic systems requiring multiple pressures for different parts of the system, yet still having a common inlet supply. | For pneumatic systems requiring an electronic to pneumatic proportional control signal. Also allows pressure regulation to be integrated into your control systems. |
| Parker Global Air Preparation Solution | P31R, P32R, P33R | P31H, P32H | P31P, P32P fits Compact & Standard |

Accessories

Today's sophisticated pneumatic systems need more than just FRL's. Often times peripheral accessory products are needed to complete your pneumatic system. Parker has what is needed to ensure safe and reliable start-ups, shut-downs, and lockouts, etc.





| Function | Ball Valve | Slide Valve | Soft Start / Quick Dump | Soft Start | Quick Dump | Manifold Block |
|-----------------------------------------------|------------------------------------|------------------------------------|-----------------------------------------|--------------------------------------------|-----------------------------------------|-----------------------------------------|
| Soft Start Function | ⊘ | ⊘ | ✔ | ✔ | ⊘ | ⊘ |
| Quick Dump Function | Slow Exhaust | Slow Exhaust | ✔ | ⊘ | ✔ | ⊘ |
| Operation | Manual Twist | Manual Slide | Solenoid or Air Pilot | Solenoid, Air Pilot, or Internal Air Pilot | Solenoid or Air Pilot | N/A |
| Placement | Before or after FRL or stand alone | Before or after FRL or stand alone | After FRL | After FRL | After FRL | Anywhere within FRL or stand alone |
| Parker Global Air Preparation Solution | P31V, P32V, P33V | P31V, P32V, P33V | P31T Mini, P32T fits Compact & Standard | P31S Mini, P32S fits Compact & Standard | P31D Mini, P32D fits Compact & Standard | P31M Mini, P33M fits Compact & Standard |

Application Guide

FRL to Valve: The chart below contains recommendations for the correct selection of Global Air Preparation units to suit the number and size of valves in a typical application.

| | P31 Mini Series | | | | P32 Compact Series | | | | | | P33 Standard Series | | | | | |
|---------------------------------------|---------------------------------------------|---|---|---|--------------------|---|---|---|---|----|---------------------|----|----|----|----|----|
| | Number of valves that would actuate at once | | | | | | | | | | | | | | | |
| | 1 | 2 | 3 | 4 | 5 | 6 | 7 | 8 | 9 | 10 | 11 | 12 | 13 | 14 | 15 | 16 |
| Moduflex 1 | | | | | | | | | | | | | | | | |
| Isys Micro | | | | | | | | | | | | | | | | |
| HB / Viking Xtreme | | | | | | | | | | | | | | | | |
| Moduflex 2 | | | | | | | | | | | | | | | | |
| HA / Global ISO | | | | | | | | | | | | | | | | |
| See Larger Parker FRL Offering | | | | | | | | | | | | | | | | |

Actuator to FRL: The chart below contains recommendations for the correct selection of Global Air Preparation units suitable for each cylinder size. If you have a tube length over 2 m, choose one tube size larger than the chart. The table is based on a Maximum cylinder speed of 0.5m/s

| Cyl Ø mm Cyl Ø inches | | Cylinder bore size | | | | | | | | | | | | | | |
|----------------------------------------------|----|-------------------------------------------------------------------------------------|--------------|--------------|-------------|-------------------------------------------------------------------------------------|---------------|---------------|---------------|---------------------------------------------------------------------------------------|-------------|---------------|-------------|---------------------------------------|-------------|--|
| | | 5 (5/16) | 10 (7/16) | 16 (9/16) | 20 (3/4) | 25 (1) | 28 (1-1/8) | 32 (1-1/4) | 40 (1-1/2) | 45 (1-3/4) | 50 (2) | 63 (2-1/2) | 75 (3) | 80 (3-1/4) | 100 (4) | |
| Tube Ø mm Tube Ø inches | | Tube diameter external | | | | | | | | | | | | | | |
| | | 4 (5/32) | 4 (5/32) | 4 (5/32) | 6 (1/4) | 6 (1/4) | 6 (1/4) | 6 (1/4) | 8 (5/16) | 8 (5/16) | 8 (5/16) | 10 (3/8) | 10 (3/8) | 12 (1/2) | 12 (1/2) | |
| Number of cylinders actuating at once | 1 | | | | | | | | | | | | | | | |
| | 2 | | | | | | | | | | | | | | | |
| | 3 | | | | | | | | | | | | | | | |
| | 4 | | | | | | | | | | | | | | | |
| | 5 | | | | | | | | | | | | | | | |
| | 6 | | | | | | | | | | | | | | | |
| | 7 | | | | | | | | | | | | | | | |
| | 8 | | | | | | | | | | | | | | | |
| | 9 | | | | | | | | | | | | | | | |
| | 10 | | | | | | | | | | | | | | | |
| | | P31 Mini Series | | | | P32 Compact Series | | | | P33 Standard Series | | | | See Larger Parker FRL Offering | | |
| | |  | | | |  | | | |  | | | | | | |

Note: Data listed above is simply a guideline for a typical application only. Proper sizing and correct flow requirements must be taken into account.

Popular Combinations

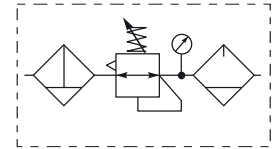

Filter + Regulator + Lubricator Combinations + Poly bowl
5 micron element, 8 bar (116 psig) Regulator + Gauge and Wall Mounting Brackets
Inlet pressure 10 bar (145 psig), Secondary pressure 6.3 bar (91.3 psig),
1 bar (14.5 psig) pressure drop.

| Port size | Flow dm ³ /s (scfm) | Manual Drain | Weight | Pulse Drain | Weight |
|-----------|-----------------------------------|------------------------|--------------------|------------------------|--------------------|
| 1/4" | 13 27 | P31CB92GEMN5LNW | 0.46 kg (1.01 lbs) | P31CB92GEBN5LNW | 0.46 kg (1.01 lbs) |

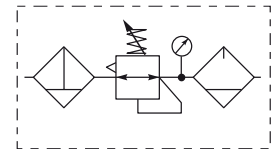

Filter/Regulator + Lubricator Combinations + Poly bowl
5 micron element, 8 bar (116 psig) Regulator + Gauge and Wall Mounting Brackets
Inlet pressure 10 bar (145 psig), Secondary pressure 6.3 bar (91.3 psig),
1 bar (14.5 psig) pressure drop.

| Port size | Flow dm ³ /s (scfm) | Manual Drain | Weight | Pulse Drain | Weight |
|-----------|-----------------------------------|------------------------|--------------------|------------------------|--------------------|
| 1/4" | 14 28 | P31CA92GEMN5LNW | 0.35 kg (0.77 lbs) | P31CA92GEBN5LNW | 0.35 kg (0.77 lbs) |

| Filter / Regulator coding (use with codes: A M) | | Filter coding (use with combo codes: B F G). For multiple filters, repeat as needed | Regulator coding (use with combo code: B) | Lubricator coding (use with combo codes: A B) | Assembly configuration | | | | | | | | | | | | | | | | | | | | | | | | | | | | | | | | | | | | | | | | | | | | | | | | | | | | | | | | | | | | | | | | | | | | | | | | | | | | | | | | | | | | | | | | | | | | | | | | | | | | | | | | | | | | | | | | | | | | | | | | | | | | | | | | | | | | | | | | | | | | | | | | | | | | | | | | | | | | | | | | | | | | | | | | | | | | | | | | | | | | | | | | |
|---------------------------------------------------------------------------------------------------------------------------------------------------------------------------------------------------------------------------------------------------------------------------------------------------------------------------------------------------------------------------------------------------------------------------------------------------------------------------------------------------------------------------------------------------------------------------------------------------------------------------------------------------------------------------------------------------------------------------------------------------------------------------------------------------------------------------------------------------------------------------------------------------------------------------------------------------------------------------------------------------------------------------------------------------------------------------------------------------------------------------------------------------------------------------------------------------------------------------------------------------------------------------------------------------------------------------------------------------------------------------------------------------------------------------------------------------------------------------------------------------------------------------------------------------------------------------------------------------------------------------------------------------------------------------------------------------------------------------------------------------------------------------------------------------------------------------------------------------------------------------------------------------------------------------------------------------------------------------------------------------------------------------------------------------------------------------------------------------------------------------------------------------------------------------------------------------------------------------------------------------------------------------------------------------------------------------------------------------------------------------------------------------------------------------------------------------------------------------------------------------------------------------------------------------------------------------------------------------------------------------------------------------------------------------------------------------------------------------------------------------------------------------------------------------------------------------------------------------------------------------------------------------------------------------------------------------------------------------------------------------------------------------------------------------------------------------------------------------------------------------------------------------------------------------------------------------------------------------------------------------------------------------------------------------------------------------------------------------------------------------------------------------------------------------------------------------------------------------------------------------------------------------------------------------------------------------------------------------------------------------------------------------------------------------------------------------------------------------------------------------------------------------------------------------|---------------|----------------------------------------------------------------------------------------|----------------------------------------------|--------------------------------------------------|------------------------|----------------------------|--|----------------------------------------------------------------------------------------------------------------------------------------------------------------------------------------------------------------------------------------------|----------------------|-------------------------------------------------------------------|----------------------|-------------------------|----------------|-------------------|---------------|--------------|----------------|--------------|--------------------------------------------------------------------------------------------------------------------------------------------------------------------------------------------------------------------------------------------|-----------------|-----|------------------------------|--------------|---------------|--------------|-------------------|--------------|--------------|----------|---------------|----------|--|--|------------|----------------------|-------------|-----------|-------------|----------|-----|----------|------------|----------|--|--|------------------|----------------------|-------------------------|-----------|------------------------|----------|------------------|--|----------|----------|--|--|----------------------------------------------------------------------------------------------------------------------------------------------------------------------------------------------------------------------------------------------|------|-----|----------------|---------------|---------------|--------------|----------------|--------------|--------------------------------------------------------------------------------------------------------------------------------------------------------------------------------------------------------------------------------------------|------|-----|---------------|--------------|---------------|--------------|----------------|--------------|--------------|----------|------------------------|----------|--|--|-------------------|--|--|--|--|--|-------------------------------------------------------------------|--|--------------------------|--|--|--|--------------|--|--|--|--|--|--|--|-------|----------|--|--|-------------|--|--|--|--|--|--|--|-------|----------|--|--|--|--|--|--|--|--|--|--|------|----------|--|--|--|--|--|--|--|--|--|--|---------|----------|--|--|--|--|--|--|--|--|--|--|--------|----------|--|--|--|--|--|--|--|--|--|--|----------|----------|--|--|--|--|--|--|--|--|--|--|------------------|--|---------------------------|----------|--------------------------------|----------|--|--|--|--|--|--|--|--|--|--|
| <p>P 3 1</p> <table border="1"> <tr> <td colspan="2">Combination</td> <td colspan="2">Thread type</td> <td colspan="2">Element</td> <td colspan="2">Relief / Adjustment</td> <td colspan="2">Lub type</td> <td colspan="2">Mounting</td> </tr> <tr> <td>B/V + Combination</td> <td>Q</td> <td>BSPP</td> <td>1</td> <td>5µ Element</td> <td>E</td> <td colspan="2">Non-rising knob</td> <td>Oil mist standard sight dome</td> <td>L</td> <td>No bracket</td> <td>A</td> </tr> <tr> <td>Combination + B/V</td> <td>X</td> <td>BSPT</td> <td>2</td> <td>0.01µ Element</td> <td>C</td> <td colspan="2"></td> <td rowspan="2">Drain type</td> <td rowspan="2">No drain; closed end</td> <td>Port blocks</td> <td>C*</td> </tr> <tr> <td>Combination</td> <td>C</td> <td>NPT</td> <td>9</td> <td>1µ Element</td> <td>9</td> <td colspan="2"></td> <td rowspan="2">Adjustment range</td> <td rowspan="2">No drain; closed end</td> <td>Port blocks & wall brkt</td> <td>D*</td> </tr> <tr> <td>Shut off + Combination</td> <td>Y</td> <td colspan="2">Port size</td> <td>Adsorber</td> <td>A</td> <td colspan="2"></td> <td rowspan="2"> <table border="1"> <tr> <th>psig</th> <th>bar</th> </tr> <tr> <td>30* = 1</td> <td>2* = V</td> </tr> <tr> <td>60 = 3</td> <td>4 = S</td> </tr> <tr> <td>125 = 5</td> <td>8 = T</td> </tr> </table> </td> <td rowspan="2"> <table border="1"> <tr> <th>psig</th> <th>bar</th> </tr> <tr> <td>30 = Y</td> <td>2 = Y</td> </tr> <tr> <td>60 = L</td> <td>4 = L</td> </tr> <tr> <td>125 = N</td> <td>8 = N</td> </tr> </table> </td> <td>Wall bracket</td> <td>W</td> </tr> <tr> <td>Combination + Shut off</td> <td>Z</td> <td colspan="2"></td> <td colspan="2">Drain type</td> <td colspan="2"></td> <td colspan="2"></td> <td colspan="2">* For 3/8" Port Blocks please order separately. See Kits section.</td> </tr> <tr> <td colspan="2">Combination type*</td> <td colspan="2"></td> <td colspan="2">Manual drain</td> <td colspan="2"></td> <td colspan="2"></td> <td colspan="2"></td> </tr> <tr> <td>F/R+L</td> <td>A</td> <td colspan="2"></td> <td colspan="2">Pulse drain</td> <td colspan="2"></td> <td colspan="2"></td> <td colspan="2"></td> </tr> <tr> <td>F+R+L</td> <td>B</td> <td colspan="2"></td> <td colspan="2"></td> <td colspan="2"></td> <td colspan="2"></td> <td colspan="2"></td> </tr> <tr> <td>F+Fc</td> <td>F</td> <td colspan="2"></td> <td colspan="2"></td> <td colspan="2"></td> <td colspan="2"></td> <td colspan="2"></td> </tr> <tr> <td>F+Fc+Fa</td> <td>G</td> <td colspan="2"></td> <td colspan="2"></td> <td colspan="2"></td> <td colspan="2"></td> <td colspan="2"></td> </tr> <tr> <td>F/R+Fc</td> <td>M</td> <td colspan="2"></td> <td colspan="2"></td> <td colspan="2"></td> <td colspan="2"></td> <td colspan="2"></td> </tr> <tr> <td>F+Fc1+Fc</td> <td>Q</td> <td colspan="2"></td> <td colspan="2"></td> <td colspan="2"></td> <td colspan="2"></td> <td colspan="2"></td> </tr> </table> <p>* Combination type F = 5µ Fc1 = 1µ Fc = .01µ Fa = Adsorber</p> <table border="1"> <tr> <td colspan="2">Bowl type</td> </tr> <tr> <td>Poly bowl with bowl guard</td> <td>G</td> </tr> <tr> <td>Metal bowl without sight gauge</td> <td>M</td> </tr> </table> <p>Note: All bowl types are the same for each component Example: If a "G" is specified for a F+L, both units would get a poly bowl with bowl guard.</p> | | Combination | | Thread type | | Element | | Relief / Adjustment | | Lub type | | Mounting | | B/V + Combination | Q | BSPP | 1 | 5µ Element | E | Non-rising knob | | Oil mist standard sight dome | L | No bracket | A | Combination + B/V | X | BSPT | 2 | 0.01µ Element | C | | | Drain type | No drain; closed end | Port blocks | C* | Combination | C | NPT | 9 | 1µ Element | 9 | | | Adjustment range | No drain; closed end | Port blocks & wall brkt | D* | Shut off + Combination | Y | Port size | | Adsorber | A | | | <table border="1"> <tr> <th>psig</th> <th>bar</th> </tr> <tr> <td>30* = 1</td> <td>2* = V</td> </tr> <tr> <td>60 = 3</td> <td>4 = S</td> </tr> <tr> <td>125 = 5</td> <td>8 = T</td> </tr> </table> | psig | bar | 30* = 1 | 2* = V | 60 = 3 | 4 = S | 125 = 5 | 8 = T | <table border="1"> <tr> <th>psig</th> <th>bar</th> </tr> <tr> <td>30 = Y</td> <td>2 = Y</td> </tr> <tr> <td>60 = L</td> <td>4 = L</td> </tr> <tr> <td>125 = N</td> <td>8 = N</td> </tr> </table> | psig | bar | 30 = Y | 2 = Y | 60 = L | 4 = L | 125 = N | 8 = N | Wall bracket | W | Combination + Shut off | Z | | | Drain type | | | | | | * For 3/8" Port Blocks please order separately. See Kits section. | | Combination type* | | | | Manual drain | | | | | | | | F/R+L | A | | | Pulse drain | | | | | | | | F+R+L | B | | | | | | | | | | | F+Fc | F | | | | | | | | | | | F+Fc+Fa | G | | | | | | | | | | | F/R+Fc | M | | | | | | | | | | | F+Fc1+Fc | Q | | | | | | | | | | | Bowl type | | Poly bowl with bowl guard | G | Metal bowl without sight gauge | M | | | | | | | | | | |
| Combination | | Thread type | | Element | | Relief / Adjustment | | Lub type | | Mounting | | | | | | | | | | | | | | | | | | | | | | | | | | | | | | | | | | | | | | | | | | | | | | | | | | | | | | | | | | | | | | | | | | | | | | | | | | | | | | | | | | | | | | | | | | | | | | | | | | | | | | | | | | | | | | | | | | | | | | | | | | | | | | | | | | | | | | | | | | | | | | | | | | | | | | | | | | | | | | | | | | | | | | | | | | | | | | | | | | | |
| B/V + Combination | Q | BSPP | 1 | 5µ Element | E | Non-rising knob | | Oil mist standard sight dome | L | No bracket | A | | | | | | | | | | | | | | | | | | | | | | | | | | | | | | | | | | | | | | | | | | | | | | | | | | | | | | | | | | | | | | | | | | | | | | | | | | | | | | | | | | | | | | | | | | | | | | | | | | | | | | | | | | | | | | | | | | | | | | | | | | | | | | | | | | | | | | | | | | | | | | | | | | | | | | | | | | | | | | | | | | | | | | | | | | | | | | | | | | |
| Combination + B/V | X | BSPT | 2 | 0.01µ Element | C | | | Drain type | No drain; closed end | Port blocks | C* | | | | | | | | | | | | | | | | | | | | | | | | | | | | | | | | | | | | | | | | | | | | | | | | | | | | | | | | | | | | | | | | | | | | | | | | | | | | | | | | | | | | | | | | | | | | | | | | | | | | | | | | | | | | | | | | | | | | | | | | | | | | | | | | | | | | | | | | | | | | | | | | | | | | | | | | | | | | | | | | | | | | | | | | | | | | | | | | | | |
| Combination | C | NPT | 9 | 1µ Element | 9 | | | | | Adjustment range | No drain; closed end | Port blocks & wall brkt | D* | | | | | | | | | | | | | | | | | | | | | | | | | | | | | | | | | | | | | | | | | | | | | | | | | | | | | | | | | | | | | | | | | | | | | | | | | | | | | | | | | | | | | | | | | | | | | | | | | | | | | | | | | | | | | | | | | | | | | | | | | | | | | | | | | | | | | | | | | | | | | | | | | | | | | | | | | | | | | | | | | | | | | | | | | | | | | | | | |
| Shut off + Combination | Y | Port size | | Adsorber | A | | | <table border="1"> <tr> <th>psig</th> <th>bar</th> </tr> <tr> <td>30* = 1</td> <td>2* = V</td> </tr> <tr> <td>60 = 3</td> <td>4 = S</td> </tr> <tr> <td>125 = 5</td> <td>8 = T</td> </tr> </table> | psig | | | bar | 30* = 1 | 2* = V | 60 = 3 | 4 = S | 125 = 5 | 8 = T | <table border="1"> <tr> <th>psig</th> <th>bar</th> </tr> <tr> <td>30 = Y</td> <td>2 = Y</td> </tr> <tr> <td>60 = L</td> <td>4 = L</td> </tr> <tr> <td>125 = N</td> <td>8 = N</td> </tr> </table> | psig | bar | 30 = Y | 2 = Y | 60 = L | 4 = L | 125 = N | 8 = N | Wall bracket | W | | | | | | | | | | | | | | | | | | | | | | | | | | | | | | | | | | | | | | | | | | | | | | | | | | | | | | | | | | | | | | | | | | | | | | | | | | | | | | | | | | | | | | | | | | | | | | | | | | | | | | | | | | | | | | | | | | | | | | | | | | | | | | | | | | | | | | | | | | | | | | | | | | | | | | | | | | | | | | | | |
| psig | bar | | | | | | | | | | | | | | | | | | | | | | | | | | | | | | | | | | | | | | | | | | | | | | | | | | | | | | | | | | | | | | | | | | | | | | | | | | | | | | | | | | | | | | | | | | | | | | | | | | | | | | | | | | | | | | | | | | | | | | | | | | | | | | | | | | | | | | | | | | | | | | | | | | | | | | | | | | | | | | | | | | | | | | | | | | | | | | | | | | | | | | | | | | | | |
| 30* = 1 | 2* = V | | | | | | | | | | | | | | | | | | | | | | | | | | | | | | | | | | | | | | | | | | | | | | | | | | | | | | | | | | | | | | | | | | | | | | | | | | | | | | | | | | | | | | | | | | | | | | | | | | | | | | | | | | | | | | | | | | | | | | | | | | | | | | | | | | | | | | | | | | | | | | | | | | | | | | | | | | | | | | | | | | | | | | | | | | | | | | | | | | | | | | | | | | | | |
| 60 = 3 | 4 = S | | | | | | | | | | | | | | | | | | | | | | | | | | | | | | | | | | | | | | | | | | | | | | | | | | | | | | | | | | | | | | | | | | | | | | | | | | | | | | | | | | | | | | | | | | | | | | | | | | | | | | | | | | | | | | | | | | | | | | | | | | | | | | | | | | | | | | | | | | | | | | | | | | | | | | | | | | | | | | | | | | | | | | | | | | | | | | | | | | | | | | | | | | | | |
| 125 = 5 | 8 = T | | | | | | | | | | | | | | | | | | | | | | | | | | | | | | | | | | | | | | | | | | | | | | | | | | | | | | | | | | | | | | | | | | | | | | | | | | | | | | | | | | | | | | | | | | | | | | | | | | | | | | | | | | | | | | | | | | | | | | | | | | | | | | | | | | | | | | | | | | | | | | | | | | | | | | | | | | | | | | | | | | | | | | | | | | | | | | | | | | | | | | | | | | | | |
| psig | bar | | | | | | | | | | | | | | | | | | | | | | | | | | | | | | | | | | | | | | | | | | | | | | | | | | | | | | | | | | | | | | | | | | | | | | | | | | | | | | | | | | | | | | | | | | | | | | | | | | | | | | | | | | | | | | | | | | | | | | | | | | | | | | | | | | | | | | | | | | | | | | | | | | | | | | | | | | | | | | | | | | | | | | | | | | | | | | | | | | | | | | | | | | | | |
| 30 = Y | 2 = Y | | | | | | | | | | | | | | | | | | | | | | | | | | | | | | | | | | | | | | | | | | | | | | | | | | | | | | | | | | | | | | | | | | | | | | | | | | | | | | | | | | | | | | | | | | | | | | | | | | | | | | | | | | | | | | | | | | | | | | | | | | | | | | | | | | | | | | | | | | | | | | | | | | | | | | | | | | | | | | | | | | | | | | | | | | | | | | | | | | | | | | | | | | | | |
| 60 = L | 4 = L | | | | | | | | | | | | | | | | | | | | | | | | | | | | | | | | | | | | | | | | | | | | | | | | | | | | | | | | | | | | | | | | | | | | | | | | | | | | | | | | | | | | | | | | | | | | | | | | | | | | | | | | | | | | | | | | | | | | | | | | | | | | | | | | | | | | | | | | | | | | | | | | | | | | | | | | | | | | | | | | | | | | | | | | | | | | | | | | | | | | | | | | | | | | |
| 125 = N | 8 = N | | | | | | | | | | | | | | | | | | | | | | | | | | | | | | | | | | | | | | | | | | | | | | | | | | | | | | | | | | | | | | | | | | | | | | | | | | | | | | | | | | | | | | | | | | | | | | | | | | | | | | | | | | | | | | | | | | | | | | | | | | | | | | | | | | | | | | | | | | | | | | | | | | | | | | | | | | | | | | | | | | | | | | | | | | | | | | | | | | | | | | | | | | | | |
| Combination + Shut off | Z | | | Drain type | | | | | | * For 3/8" Port Blocks please order separately. See Kits section. | | | | | | | | | | | | | | | | | | | | | | | | | | | | | | | | | | | | | | | | | | | | | | | | | | | | | | | | | | | | | | | | | | | | | | | | | | | | | | | | | | | | | | | | | | | | | | | | | | | | | | | | | | | | | | | | | | | | | | | | | | | | | | | | | | | | | | | | | | | | | | | | | | | | | | | | | | | | | | | | | | | | | | | | | | | | | | | | | | | |
| Combination type* | | | | Manual drain | | | | | | | | | | | | | | | | | | | | | | | | | | | | | | | | | | | | | | | | | | | | | | | | | | | | | | | | | | | | | | | | | | | | | | | | | | | | | | | | | | | | | | | | | | | | | | | | | | | | | | | | | | | | | | | | | | | | | | | | | | | | | | | | | | | | | | | | | | | | | | | | | | | | | | | | | | | | | | | | | | | | | | | | | | | | | | | | | | | | | | | | | |
| F/R+L | A | | | Pulse drain | | | | | | | | | | | | | | | | | | | | | | | | | | | | | | | | | | | | | | | | | | | | | | | | | | | | | | | | | | | | | | | | | | | | | | | | | | | | | | | | | | | | | | | | | | | | | | | | | | | | | | | | | | | | | | | | | | | | | | | | | | | | | | | | | | | | | | | | | | | | | | | | | | | | | | | | | | | | | | | | | | | | | | | | | | | | | | | | | | | | | | | | | |
| F+R+L | B | | | | | | | | | | | | | | | | | | | | | | | | | | | | | | | | | | | | | | | | | | | | | | | | | | | | | | | | | | | | | | | | | | | | | | | | | | | | | | | | | | | | | | | | | | | | | | | | | | | | | | | | | | | | | | | | | | | | | | | | | | | | | | | | | | | | | | | | | | | | | | | | | | | | | | | | | | | | | | | | | | | | | | | | | | | | | | | | | | | | | | | | | | | | |
| F+Fc | F | | | | | | | | | | | | | | | | | | | | | | | | | | | | | | | | | | | | | | | | | | | | | | | | | | | | | | | | | | | | | | | | | | | | | | | | | | | | | | | | | | | | | | | | | | | | | | | | | | | | | | | | | | | | | | | | | | | | | | | | | | | | | | | | | | | | | | | | | | | | | | | | | | | | | | | | | | | | | | | | | | | | | | | | | | | | | | | | | | | | | | | | | | | | |
| F+Fc+Fa | G | | | | | | | | | | | | | | | | | | | | | | | | | | | | | | | | | | | | | | | | | | | | | | | | | | | | | | | | | | | | | | | | | | | | | | | | | | | | | | | | | | | | | | | | | | | | | | | | | | | | | | | | | | | | | | | | | | | | | | | | | | | | | | | | | | | | | | | | | | | | | | | | | | | | | | | | | | | | | | | | | | | | | | | | | | | | | | | | | | | | | | | | | | | | |
| F/R+Fc | M | | | | | | | | | | | | | | | | | | | | | | | | | | | | | | | | | | | | | | | | | | | | | | | | | | | | | | | | | | | | | | | | | | | | | | | | | | | | | | | | | | | | | | | | | | | | | | | | | | | | | | | | | | | | | | | | | | | | | | | | | | | | | | | | | | | | | | | | | | | | | | | | | | | | | | | | | | | | | | | | | | | | | | | | | | | | | | | | | | | | | | | | | | | | |
| F+Fc1+Fc | Q | | | | | | | | | | | | | | | | | | | | | | | | | | | | | | | | | | | | | | | | | | | | | | | | | | | | | | | | | | | | | | | | | | | | | | | | | | | | | | | | | | | | | | | | | | | | | | | | | | | | | | | | | | | | | | | | | | | | | | | | | | | | | | | | | | | | | | | | | | | | | | | | | | | | | | | | | | | | | | | | | | | | | | | | | | | | | | | | | | | | | | | | | | | | |
| Bowl type | | | | | | | | | | | | | | | | | | | | | | | | | | | | | | | | | | | | | | | | | | | | | | | | | | | | | | | | | | | | | | | | | | | | | | | | | | | | | | | | | | | | | | | | | | | | | | | | | | | | | | | | | | | | | | | | | | | | | | | | | | | | | | | | | | | | | | | | | | | | | | | | | | | | | | | | | | | | | | | | | | | | | | | | | | | | | | | | | | | | | | | | | | | | | |
| Poly bowl with bowl guard | G | | | | | | | | | | | | | | | | | | | | | | | | | | | | | | | | | | | | | | | | | | | | | | | | | | | | | | | | | | | | | | | | | | | | | | | | | | | | | | | | | | | | | | | | | | | | | | | | | | | | | | | | | | | | | | | | | | | | | | | | | | | | | | | | | | | | | | | | | | | | | | | | | | | | | | | | | | | | | | | | | | | | | | | | | | | | | | | | | | | | | | | | | | | | |
| Metal bowl without sight gauge | M | | | | | | | | | | | | | | | | | | | | | | | | | | | | | | | | | | | | | | | | | | | | | | | | | | | | | | | | | | | | | | | | | | | | | | | | | | | | | | | | | | | | | | | | | | | | | | | | | | | | | | | | | | | | | | | | | | | | | | | | | | | | | | | | | | | | | | | | | | | | | | | | | | | | | | | | | | | | | | | | | | | | | | | | | | | | | | | | | | | | | | | | | | | | |

Global Air Preparation System

Popular Combinations

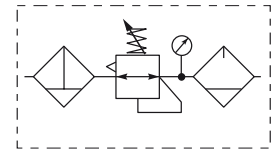

Filter + Regulator + Lubricator Combinations + Poly bowl
5 micron element, 8 bar (116 psig) Regulator + Gauge and Wall Mounting Brackets
Inlet pressure 10 bar (145 psig), Secondary pressure 6.3 bar (91.3 psig),
1 bar (14.5 psig) pressure drop.

| Port size | Flow dm ³ /s (scfm) | Manual Drain | Weight | Auto Drain | Weight |
|-----------|--------------------------------------|------------------------|--------------------|------------------------|--------------------|
| 1/4" | 20 42 | P32CB92GEMNGLNW | 1.29 kg (2.84 lbs) | P32CB92GEANGLNW | 1.29 kg (2.84 lbs) |
| 3/8" | 32 68 | P32CB93GEMNGLNW | 1.29 kg (2.84 lbs) | P32CB93GEANGLNW | 1.29 kg (2.84 lbs) |
| 1/2" | 40 85 | P32CB94GEMNGLNW | 1.29 kg (2.84 lbs) | P32CB94GEANGLNW | 1.29 kg (2.84 lbs) |

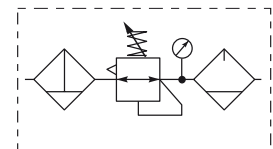

Filter/Regulator + Lubricator Combinations + Poly bowl
5 micron element, 8 bar (116 psig) Regulator + Gauge and Wall Mounting Brackets
Inlet pressure 10 bar (145 psig), Secondary pressure 6.3 bar (91.3 psig),
1 bar (14.5 psig) pressure drop.

| Port size | Flow dm ³ /s (scfm) | Manual Drain | Weight | Auto Drain | Weight |
|-----------|--------------------------------------|------------------------|--------------------|------------------------|--------------------|
| 1/4" | 22 45 | P32CA92GEMNGLNW | 1.03 kg (2.27 lbs) | P32CA92GEANGLNW | 1.03 kg (2.27 lbs) |
| 3/8" | 33 70 | P32CA93GEMNGLNW | 1.03 kg (2.27 lbs) | P32CA93GEANGLNW | 1.03 kg (2.27 lbs) |
| 1/2" | 43 90 | P32CA94GEMNGLNW | 1.03 kg (2.27 lbs) | P32CA94GEANGLNW | 1.03 kg (2.27 lbs) |

Filter / Regulator coding
(use with codes: A M)

| Filter coding | Regulator coding | Lubricator coding | Assembly configuration | | | | | | | | | | | | | | | | | | | | | | | | | | | | | | | | | | | | | | | | | | | | | | | | | | | | | | | | | | | | | | | | | | | | | | | | | | | | | | | | | | | | | | | | | | | | | | | | | | | | | | | | | | | | | | | | | | |
|------------------------------------------------------------------------------------------------------------------------------------------------------------------------------------------------------------------------------------------------------------------------------------------------------------------------------------------------------------------------------------------------------------------------------------------------------------------------------------------------------------------------------------------------------------------------------------------------------------------------------------------------------------------------------------------------------------------------------------------------------------------------------------------------------------------------------------------------------------------------------------------------------------------------------------------------------------------------------------------------------------------------------------------------------------------------------------------------------------------------------------------------------------------------------------------------------------------------------------------------------------------------------------------------------------------------------------------------------------------------------------------------------------------------------------------------------------------------------------------------------------------------------------------------------------------------------------------------------------------------------------|--------------------------|-----------------------------|------------------------|--|-------------------|----------|------|----------|-------------------|----------|------|----------|-------------|----------|-----|----------|------------------------|----------|------------------|--|------------------------|----------|------|----------|--------------------------|--|------|----------|-------|----------|---------|----------|-------|----------|--------|----------|------|----------|----------|----------|------------------|--|---------------------------|----------|--------------------------------|----------|-----------------------------|----------|----------------------------------------------------------------------------------------------------------------------------------------------------------------------------------------------------------------------------------------------------------------------------------------------------------------------------------------------------------------------------------------------------------------------------------------------------------------------------------------------------------------------------------------------------------------------------------------------------------------------------------------------------------------------------------------|----------------|--|---------------|----------|------------------------|-----------|------------|----------|---------------------|-----------|------------|----------|---------------------|-----------|----------|----------|-------------------|--|------------|----------|--------------|----------|----------------------------------------------------------------------------------------------------------------------------------------------------------------------------------------------------------------------------------------------------------------------------------------------------------------------------------------------------------------------------------------------------------------------------------------------------------------------------------------------------------------------------------------------------------------------------------------------------------------------------------------------------------------------------------------------------------------------------------------------------------------------------------------------------------------------------------------------------------------------------------------------------------------------------------------|----------------------------|--|---------------------------|----------|-------------------------|--|-------------------------|--|-------------------------|----------|-------------------------|----------|--------------------------|----------|---------------------------|-----------|----------------------|--|-------------------------|----------|-------------------------|----------|--------------------------|----------|---------------------------|-----------|---------------------------------------------------------------------------------------------------------------------------------------------------------------------------------------------------------------------------------------------------------------------------------------------------------------------------------------------------------------------------------------------------------------------------------------------------------------------------------------------------------------------------------------------------------------------------------------------|-----------------|--|------------------------------|----------|-------------------|--|----------------------|----------|-----------------|--|------------|----------|-------------|----------|-------------------------|----------|--------------|----------|
| (use with combo codes: B F G). For multiple filters, repeat as needed | (use with combo code: B) | (use with combo codes: A B) | | | | | | | | | | | | | | | | | | | | | | | | | | | | | | | | | | | | | | | | | | | | | | | | | | | | | | | | | | | | | | | | | | | | | | | | | | | | | | | | | | | | | | | | | | | | | | | | | | | | | | | | | | | | | | | | | | | |
| <p>P 3 2</p> <table border="1"> <tr> <td colspan="2">Combination</td> <td colspan="2">Thread type</td> </tr> <tr> <td>B/V + Combination</td> <td>Q</td> <td>BSPP</td> <td>1</td> </tr> <tr> <td>Combination + B/V</td> <td>X</td> <td>BSPT</td> <td>2</td> </tr> <tr> <td>Combination</td> <td>C</td> <td>NPT</td> <td>9</td> </tr> <tr> <td>Shut off + Combination</td> <td>Y</td> <td colspan="2">Port size</td> </tr> <tr> <td>Combination + Shut off</td> <td>Z</td> <td>1/4"</td> <td>2</td> </tr> <tr> <td colspan="2">Combination type*</td> <td>3/8"</td> <td>3</td> </tr> <tr> <td>F/R+L</td> <td>A</td> <td>F+Fc+Fa</td> <td>G</td> </tr> <tr> <td>F+R+L</td> <td>B</td> <td>F/R+Fc</td> <td>M</td> </tr> <tr> <td>F+Fc</td> <td>F</td> <td>F+Fc1+Fc</td> <td>Q</td> </tr> </table> <p>* Combination type F = 5µ Fc1 = 1µ Fc = .01µ Fa = Adsorber</p> <table border="1"> <tr> <td colspan="2">Bowl type</td> </tr> <tr> <td>Poly bowl with bowl guard</td> <td>G</td> </tr> <tr> <td>Metal bowl without sight gauge</td> <td>M</td> </tr> <tr> <td>Metal bowl with sight gauge</td> <td>S</td> </tr> </table> <p>* Not available when using lubricator. Note: All bowl types are the same for each component. Example: If a "G" is specified for a F+L, both units would get a poly bowl with bowl guard.</p> | Combination | | Thread type | | B/V + Combination | Q | BSPP | 1 | Combination + B/V | X | BSPT | 2 | Combination | C | NPT | 9 | Shut off + Combination | Y | Port size | | Combination + Shut off | Z | 1/4" | 2 | Combination type* | | 3/8" | 3 | F/R+L | A | F+Fc+Fa | G | F+R+L | B | F/R+Fc | M | F+Fc | F | F+Fc1+Fc | Q | Bowl type | | Poly bowl with bowl guard | G | Metal bowl without sight gauge | M | Metal bowl with sight gauge | S | <table border="1"> <tr> <td colspan="2">Element</td> </tr> <tr> <td>0.01µ Element</td> <td>C</td> </tr> <tr> <td>0.01µ Element with dpi</td> <td>D*</td> </tr> <tr> <td>5µ Element</td> <td>E</td> </tr> <tr> <td>5µ Element with dpi</td> <td>F*</td> </tr> <tr> <td>1µ Element</td> <td>9</td> </tr> <tr> <td>1µ Element with dpi</td> <td>Q*</td> </tr> <tr> <td>Adsorber</td> <td>A</td> </tr> </table> <p>* Not available with F/R.</p> <table border="1"> <tr> <td colspan="2">Drain type</td> </tr> <tr> <td>Auto drain</td> <td>A</td> </tr> <tr> <td>Manual drain</td> <td>M</td> </tr> </table> | Element | | 0.01µ Element | C | 0.01µ Element with dpi | D* | 5µ Element | E | 5µ Element with dpi | F* | 1µ Element | 9 | 1µ Element with dpi | Q* | Adsorber | A | Drain type | | Auto drain | A | Manual drain | M | <table border="1"> <tr> <td colspan="2">Relief / Adjustment</td> </tr> <tr> <td>Non-rising knob relieving</td> <td>N</td> </tr> </table> <table border="1"> <tr> <td colspan="2">Adjustment range</td> </tr> <tr> <td colspan="2">With round gauge</td> </tr> <tr> <td>2 bar; 30 psig; 0.2 MPa</td> <td>Z</td> </tr> <tr> <td>4 bar; 60 psig; 0.4 MPa</td> <td>M</td> </tr> <tr> <td>8 bar; 125 psig; 0.8 MPa</td> <td>G</td> </tr> <tr> <td>17 bar; 250 psig; 1.7 MPa</td> <td>J*</td> </tr> <tr> <td colspan="2">Without gauge</td> </tr> <tr> <td>2 bar; 30 psig; 0.2 MPa</td> <td>Y</td> </tr> <tr> <td>4 bar; 60 psig; 0.4 MPa</td> <td>L</td> </tr> <tr> <td>8 bar; 125 psig; 0.8 MPa</td> <td>N</td> </tr> <tr> <td>17 bar; 250 psig; 1.7 MPa</td> <td>H*</td> </tr> </table> <p>* Not available with poly bowl with bowl guard.</p> | Relief / Adjustment | | Non-rising knob relieving | N | Adjustment range | | With round gauge | | 2 bar; 30 psig; 0.2 MPa | Z | 4 bar; 60 psig; 0.4 MPa | M | 8 bar; 125 psig; 0.8 MPa | G | 17 bar; 250 psig; 1.7 MPa | J* | Without gauge | | 2 bar; 30 psig; 0.2 MPa | Y | 4 bar; 60 psig; 0.4 MPa | L | 8 bar; 125 psig; 0.8 MPa | N | 17 bar; 250 psig; 1.7 MPa | H* | <table border="1"> <tr> <td colspan="2">Lub type</td> </tr> <tr> <td>Oil mist standard sight dome</td> <td>L</td> </tr> </table> <table border="1"> <tr> <td colspan="2">Drain type</td> </tr> <tr> <td>No drain; closed end</td> <td>N</td> </tr> </table> <table border="1"> <tr> <td colspan="2">Mounting</td> </tr> <tr> <td>No bracket</td> <td>A</td> </tr> <tr> <td>Port blocks</td> <td>C</td> </tr> <tr> <td>Port blocks & wall brkt</td> <td>D</td> </tr> <tr> <td>Wall bracket</td> <td>W</td> </tr> </table> | Lub type | | Oil mist standard sight dome | L | Drain type | | No drain; closed end | N | Mounting | | No bracket | A | Port blocks | C | Port blocks & wall brkt | D | Wall bracket | W |
| Combination | | Thread type | | | | | | | | | | | | | | | | | | | | | | | | | | | | | | | | | | | | | | | | | | | | | | | | | | | | | | | | | | | | | | | | | | | | | | | | | | | | | | | | | | | | | | | | | | | | | | | | | | | | | | | | | | | | | | | | | | | |
| B/V + Combination | Q | BSPP | 1 | | | | | | | | | | | | | | | | | | | | | | | | | | | | | | | | | | | | | | | | | | | | | | | | | | | | | | | | | | | | | | | | | | | | | | | | | | | | | | | | | | | | | | | | | | | | | | | | | | | | | | | | | | | | | | | | | | |
| Combination + B/V | X | BSPT | 2 | | | | | | | | | | | | | | | | | | | | | | | | | | | | | | | | | | | | | | | | | | | | | | | | | | | | | | | | | | | | | | | | | | | | | | | | | | | | | | | | | | | | | | | | | | | | | | | | | | | | | | | | | | | | | | | | | | |
| Combination | C | NPT | 9 | | | | | | | | | | | | | | | | | | | | | | | | | | | | | | | | | | | | | | | | | | | | | | | | | | | | | | | | | | | | | | | | | | | | | | | | | | | | | | | | | | | | | | | | | | | | | | | | | | | | | | | | | | | | | | | | | | |
| Shut off + Combination | Y | Port size | | | | | | | | | | | | | | | | | | | | | | | | | | | | | | | | | | | | | | | | | | | | | | | | | | | | | | | | | | | | | | | | | | | | | | | | | | | | | | | | | | | | | | | | | | | | | | | | | | | | | | | | | | | | | | | | | | | |
| Combination + Shut off | Z | 1/4" | 2 | | | | | | | | | | | | | | | | | | | | | | | | | | | | | | | | | | | | | | | | | | | | | | | | | | | | | | | | | | | | | | | | | | | | | | | | | | | | | | | | | | | | | | | | | | | | | | | | | | | | | | | | | | | | | | | | | | |
| Combination type* | | 3/8" | 3 | | | | | | | | | | | | | | | | | | | | | | | | | | | | | | | | | | | | | | | | | | | | | | | | | | | | | | | | | | | | | | | | | | | | | | | | | | | | | | | | | | | | | | | | | | | | | | | | | | | | | | | | | | | | | | | | | | |
| F/R+L | A | F+Fc+Fa | G | | | | | | | | | | | | | | | | | | | | | | | | | | | | | | | | | | | | | | | | | | | | | | | | | | | | | | | | | | | | | | | | | | | | | | | | | | | | | | | | | | | | | | | | | | | | | | | | | | | | | | | | | | | | | | | | | | |
| F+R+L | B | F/R+Fc | M | | | | | | | | | | | | | | | | | | | | | | | | | | | | | | | | | | | | | | | | | | | | | | | | | | | | | | | | | | | | | | | | | | | | | | | | | | | | | | | | | | | | | | | | | | | | | | | | | | | | | | | | | | | | | | | | | | |
| F+Fc | F | F+Fc1+Fc | Q | | | | | | | | | | | | | | | | | | | | | | | | | | | | | | | | | | | | | | | | | | | | | | | | | | | | | | | | | | | | | | | | | | | | | | | | | | | | | | | | | | | | | | | | | | | | | | | | | | | | | | | | | | | | | | | | | | |
| Bowl type | | | | | | | | | | | | | | | | | | | | | | | | | | | | | | | | | | | | | | | | | | | | | | | | | | | | | | | | | | | | | | | | | | | | | | | | | | | | | | | | | | | | | | | | | | | | | | | | | | | | | | | | | | | | | | | | | | | | | |
| Poly bowl with bowl guard | G | | | | | | | | | | | | | | | | | | | | | | | | | | | | | | | | | | | | | | | | | | | | | | | | | | | | | | | | | | | | | | | | | | | | | | | | | | | | | | | | | | | | | | | | | | | | | | | | | | | | | | | | | | | | | | | | | | | | |
| Metal bowl without sight gauge | M | | | | | | | | | | | | | | | | | | | | | | | | | | | | | | | | | | | | | | | | | | | | | | | | | | | | | | | | | | | | | | | | | | | | | | | | | | | | | | | | | | | | | | | | | | | | | | | | | | | | | | | | | | | | | | | | | | | | |
| Metal bowl with sight gauge | S | | | | | | | | | | | | | | | | | | | | | | | | | | | | | | | | | | | | | | | | | | | | | | | | | | | | | | | | | | | | | | | | | | | | | | | | | | | | | | | | | | | | | | | | | | | | | | | | | | | | | | | | | | | | | | | | | | | | |
| Element | | | | | | | | | | | | | | | | | | | | | | | | | | | | | | | | | | | | | | | | | | | | | | | | | | | | | | | | | | | | | | | | | | | | | | | | | | | | | | | | | | | | | | | | | | | | | | | | | | | | | | | | | | | | | | | | | | | | | |
| 0.01µ Element | C | | | | | | | | | | | | | | | | | | | | | | | | | | | | | | | | | | | | | | | | | | | | | | | | | | | | | | | | | | | | | | | | | | | | | | | | | | | | | | | | | | | | | | | | | | | | | | | | | | | | | | | | | | | | | | | | | | | | |
| 0.01µ Element with dpi | D* | | | | | | | | | | | | | | | | | | | | | | | | | | | | | | | | | | | | | | | | | | | | | | | | | | | | | | | | | | | | | | | | | | | | | | | | | | | | | | | | | | | | | | | | | | | | | | | | | | | | | | | | | | | | | | | | | | | | |
| 5µ Element | E | | | | | | | | | | | | | | | | | | | | | | | | | | | | | | | | | | | | | | | | | | | | | | | | | | | | | | | | | | | | | | | | | | | | | | | | | | | | | | | | | | | | | | | | | | | | | | | | | | | | | | | | | | | | | | | | | | | | |
| 5µ Element with dpi | F* | | | | | | | | | | | | | | | | | | | | | | | | | | | | | | | | | | | | | | | | | | | | | | | | | | | | | | | | | | | | | | | | | | | | | | | | | | | | | | | | | | | | | | | | | | | | | | | | | | | | | | | | | | | | | | | | | | | | |
| 1µ Element | 9 | | | | | | | | | | | | | | | | | | | | | | | | | | | | | | | | | | | | | | | | | | | | | | | | | | | | | | | | | | | | | | | | | | | | | | | | | | | | | | | | | | | | | | | | | | | | | | | | | | | | | | | | | | | | | | | | | | | | |
| 1µ Element with dpi | Q* | | | | | | | | | | | | | | | | | | | | | | | | | | | | | | | | | | | | | | | | | | | | | | | | | | | | | | | | | | | | | | | | | | | | | | | | | | | | | | | | | | | | | | | | | | | | | | | | | | | | | | | | | | | | | | | | | | | | |
| Adsorber | A | | | | | | | | | | | | | | | | | | | | | | | | | | | | | | | | | | | | | | | | | | | | | | | | | | | | | | | | | | | | | | | | | | | | | | | | | | | | | | | | | | | | | | | | | | | | | | | | | | | | | | | | | | | | | | | | | | | | |
| Drain type | | | | | | | | | | | | | | | | | | | | | | | | | | | | | | | | | | | | | | | | | | | | | | | | | | | | | | | | | | | | | | | | | | | | | | | | | | | | | | | | | | | | | | | | | | | | | | | | | | | | | | | | | | | | | | | | | | | | | |
| Auto drain | A | | | | | | | | | | | | | | | | | | | | | | | | | | | | | | | | | | | | | | | | | | | | | | | | | | | | | | | | | | | | | | | | | | | | | | | | | | | | | | | | | | | | | | | | | | | | | | | | | | | | | | | | | | | | | | | | | | | | |
| Manual drain | M | | | | | | | | | | | | | | | | | | | | | | | | | | | | | | | | | | | | | | | | | | | | | | | | | | | | | | | | | | | | | | | | | | | | | | | | | | | | | | | | | | | | | | | | | | | | | | | | | | | | | | | | | | | | | | | | | | | | |
| Relief / Adjustment | | | | | | | | | | | | | | | | | | | | | | | | | | | | | | | | | | | | | | | | | | | | | | | | | | | | | | | | | | | | | | | | | | | | | | | | | | | | | | | | | | | | | | | | | | | | | | | | | | | | | | | | | | | | | | | | | | | | | |
| Non-rising knob relieving | N | | | | | | | | | | | | | | | | | | | | | | | | | | | | | | | | | | | | | | | | | | | | | | | | | | | | | | | | | | | | | | | | | | | | | | | | | | | | | | | | | | | | | | | | | | | | | | | | | | | | | | | | | | | | | | | | | | | | |
| Adjustment range | | | | | | | | | | | | | | | | | | | | | | | | | | | | | | | | | | | | | | | | | | | | | | | | | | | | | | | | | | | | | | | | | | | | | | | | | | | | | | | | | | | | | | | | | | | | | | | | | | | | | | | | | | | | | | | | | | | | | |
| With round gauge | | | | | | | | | | | | | | | | | | | | | | | | | | | | | | | | | | | | | | | | | | | | | | | | | | | | | | | | | | | | | | | | | | | | | | | | | | | | | | | | | | | | | | | | | | | | | | | | | | | | | | | | | | | | | | | | | | | | | |
| 2 bar; 30 psig; 0.2 MPa | Z | | | | | | | | | | | | | | | | | | | | | | | | | | | | | | | | | | | | | | | | | | | | | | | | | | | | | | | | | | | | | | | | | | | | | | | | | | | | | | | | | | | | | | | | | | | | | | | | | | | | | | | | | | | | | | | | | | | | |
| 4 bar; 60 psig; 0.4 MPa | M | | | | | | | | | | | | | | | | | | | | | | | | | | | | | | | | | | | | | | | | | | | | | | | | | | | | | | | | | | | | | | | | | | | | | | | | | | | | | | | | | | | | | | | | | | | | | | | | | | | | | | | | | | | | | | | | | | | | |
| 8 bar; 125 psig; 0.8 MPa | G | | | | | | | | | | | | | | | | | | | | | | | | | | | | | | | | | | | | | | | | | | | | | | | | | | | | | | | | | | | | | | | | | | | | | | | | | | | | | | | | | | | | | | | | | | | | | | | | | | | | | | | | | | | | | | | | | | | | |
| 17 bar; 250 psig; 1.7 MPa | J* | | | | | | | | | | | | | | | | | | | | | | | | | | | | | | | | | | | | | | | | | | | | | | | | | | | | | | | | | | | | | | | | | | | | | | | | | | | | | | | | | | | | | | | | | | | | | | | | | | | | | | | | | | | | | | | | | | | | |
| Without gauge | | | | | | | | | | | | | | | | | | | | | | | | | | | | | | | | | | | | | | | | | | | | | | | | | | | | | | | | | | | | | | | | | | | | | | | | | | | | | | | | | | | | | | | | | | | | | | | | | | | | | | | | | | | | | | | | | | | | | |
| 2 bar; 30 psig; 0.2 MPa | Y | | | | | | | | | | | | | | | | | | | | | | | | | | | | | | | | | | | | | | | | | | | | | | | | | | | | | | | | | | | | | | | | | | | | | | | | | | | | | | | | | | | | | | | | | | | | | | | | | | | | | | | | | | | | | | | | | | | | |
| 4 bar; 60 psig; 0.4 MPa | L | | | | | | | | | | | | | | | | | | | | | | | | | | | | | | | | | | | | | | | | | | | | | | | | | | | | | | | | | | | | | | | | | | | | | | | | | | | | | | | | | | | | | | | | | | | | | | | | | | | | | | | | | | | | | | | | | | | | |
| 8 bar; 125 psig; 0.8 MPa | N | | | | | | | | | | | | | | | | | | | | | | | | | | | | | | | | | | | | | | | | | | | | | | | | | | | | | | | | | | | | | | | | | | | | | | | | | | | | | | | | | | | | | | | | | | | | | | | | | | | | | | | | | | | | | | | | | | | | |
| 17 bar; 250 psig; 1.7 MPa | H* | | | | | | | | | | | | | | | | | | | | | | | | | | | | | | | | | | | | | | | | | | | | | | | | | | | | | | | | | | | | | | | | | | | | | | | | | | | | | | | | | | | | | | | | | | | | | | | | | | | | | | | | | | | | | | | | | | | | |
| Lub type | | | | | | | | | | | | | | | | | | | | | | | | | | | | | | | | | | | | | | | | | | | | | | | | | | | | | | | | | | | | | | | | | | | | | | | | | | | | | | | | | | | | | | | | | | | | | | | | | | | | | | | | | | | | | | | | | | | | | |
| Oil mist standard sight dome | L | | | | | | | | | | | | | | | | | | | | | | | | | | | | | | | | | | | | | | | | | | | | | | | | | | | | | | | | | | | | | | | | | | | | | | | | | | | | | | | | | | | | | | | | | | | | | | | | | | | | | | | | | | | | | | | | | | | | |
| Drain type | | | | | | | | | | | | | | | | | | | | | | | | | | | | | | | | | | | | | | | | | | | | | | | | | | | | | | | | | | | | | | | | | | | | | | | | | | | | | | | | | | | | | | | | | | | | | | | | | | | | | | | | | | | | | | | | | | | | | |
| No drain; closed end | N | | | | | | | | | | | | | | | | | | | | | | | | | | | | | | | | | | | | | | | | | | | | | | | | | | | | | | | | | | | | | | | | | | | | | | | | | | | | | | | | | | | | | | | | | | | | | | | | | | | | | | | | | | | | | | | | | | | | |
| Mounting | | | | | | | | | | | | | | | | | | | | | | | | | | | | | | | | | | | | | | | | | | | | | | | | | | | | | | | | | | | | | | | | | | | | | | | | | | | | | | | | | | | | | | | | | | | | | | | | | | | | | | | | | | | | | | | | | | | | | |
| No bracket | A | | | | | | | | | | | | | | | | | | | | | | | | | | | | | | | | | | | | | | | | | | | | | | | | | | | | | | | | | | | | | | | | | | | | | | | | | | | | | | | | | | | | | | | | | | | | | | | | | | | | | | | | | | | | | | | | | | | | |
| Port blocks | C | | | | | | | | | | | | | | | | | | | | | | | | | | | | | | | | | | | | | | | | | | | | | | | | | | | | | | | | | | | | | | | | | | | | | | | | | | | | | | | | | | | | | | | | | | | | | | | | | | | | | | | | | | | | | | | | | | | | |
| Port blocks & wall brkt | D | | | | | | | | | | | | | | | | | | | | | | | | | | | | | | | | | | | | | | | | | | | | | | | | | | | | | | | | | | | | | | | | | | | | | | | | | | | | | | | | | | | | | | | | | | | | | | | | | | | | | | | | | | | | | | | | | | | | |
| Wall bracket | W | | | | | | | | | | | | | | | | | | | | | | | | | | | | | | | | | | | | | | | | | | | | | | | | | | | | | | | | | | | | | | | | | | | | | | | | | | | | | | | | | | | | | | | | | | | | | | | | | | | | | | | | | | | | | | | | | | | | |



Global Air Preparation System

Popular Combinations

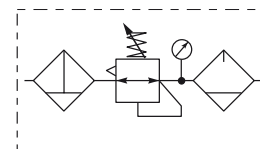

Filter + Regulator + Lubricator Combinations + Poly bowl
5 micron element, 8 bar (116 psig) Regulator + Gauge and Wall Mounting Brackets
Inlet pressure 10 bar (145 psig), Secondary pressure 6.3 bar (91.3 psig),
1 bar (14.5 psig) pressure drop.

| Port size | Flow dm ³ /s (scfm) | | Manual Drain | Weight | Auto Drain | Weight |
|-----------|-----------------------------------|-----|------------------------|--------------------|------------------------|--------------------|
| 1/2" | 43 | 90 | P33CB94GEMNGLNW | 1.84 kg (4.06 lbs) | P33CB94GEANGLNW | 1.84 kg (4.06 lbs) |
| 3/4" | 52 | 110 | P33CB96GEMNGLNW | 1.84 kg (4.06 lbs) | P33CB96GEANGLNW | 1.84 kg (4.06 lbs) |

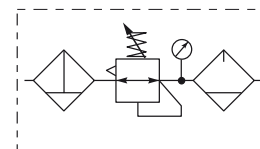

Filter/Regulator + Lubricator Combinations + Poly bowl
5 micron element, 8 bar (116 psig) Regulator + Gauge and Wall Mounting Brackets
Inlet pressure 10 bar (145 psig), Secondary pressure 6.3 bar (91.3 psig),
1 bar (14.5 psig) pressure drop.

| Port size | Flow dm ³ /s (scfm) | | Manual Drain | Weight | Auto Drain | Weight |
|-----------|-----------------------------------|-----|------------------------|--------------------|------------------------|--------------------|
| 1/2" | 52 | 110 | P33CA94GEMNGLNW | 1.51 kg (3.33 lbs) | P33CA94GEANGLNW | 1.51 kg (3.33 lbs) |
| 3/4" | 71 | 150 | P33CA96GEMNGLNW | 1.51 kg (3.33 lbs) | P33CA96GEANGLNW | 1.51 kg (3.33 lbs) |

Filter / Regulator coding
 (use with codes: A M)

| Filter coding | Regulator coding | Lubricator coding | Assembly configuration | | | | | | | |
|-------------------------------------------------------------------------------------------------------------------------------------------------------------------------------------------------------------------------------------------------------------------------------------------------------------------------------------------------------------------------------------------------------------------------------------------------------------------------------------------------------------------------------------------------------------------------------------------------------------------------------------------------------------------------------------------------------------------------------------------------------------------------------------------------------------------------------------------------------------------------------------------------------------------------------------------------------------------------------------------------------------------------------------------------------------------------------------------------------------------------------------------------------------------------------------------------------------------------------------------------------------------------------------------------------------------------------------------------------------------------------------------------------------------------------------------------------------------------------------------------------------------------------------------------------------------------------------------------------------------------------------------------------------------------------------------------------------------------------------------------------------------------------------------------------------------------------------------------------------------------------------------------------------------------|--------------------------|-----------------------------|------------------------|-----------------|---------------|-------------------|-----------------------------------------------------------------------------------------------------------------------------------------------------------------------------------------------------------------------------------------------------------------------------------------------------------------------------------------------------------------------------------------------------------------------------------------------------------------------------------------------------------------------------------------------------------------------------------------------------------------------------------------------------------|-------------------------------------------------------------------------------------------------------------------------------------------------------------------------------------------------------------------------------------------------------------------------------------------------------------------------------------------------------------------------------------------------------------------------------------------------------------------------------------------------------------------------------------------------------------------------------------------------------------------------------------------------------------------------------------------------------------------------------------------------------------------------------------------------------------------------------------------------------------------------------------------------------------------------------|-------------------------------------------------------------------------------------------------------------------------------------------------------------------------------------------------------------------------------------------------------------------------------------------------------------------------|---------------------------------------------------------------------------------------------------------------------------------------------------------------------------------------------------------------------------------------------------------------------------------------------------------|
| (use with combo codes: B F G). For multiple filters, repeat as needed | (use with combo code: B) | (use with combo codes: A B) | | | | | | | | |
| <div style="border: 1px solid black; padding: 5px; margin-bottom: 5px;"> Combination B/V + Combination Q Combination + B/V X Combination C Shut off + Combination Y Combination + Shut off Z </div> <div style="border: 1px solid black; padding: 5px; margin-bottom: 5px;"> Thread type BSPP 1 BSPT 2 NPT 9 </div> <div style="border: 1px solid black; padding: 5px; margin-bottom: 5px;"> Port size 1/2 4 3/4 6 </div> <div style="border: 1px solid black; padding: 5px; margin-bottom: 5px;"> Combination type* <table style="width: 100%; border-collapse: collapse;"> <tr> <td style="border: 1px solid black;">F/R+L A</td> <td style="border: 1px solid black;">F+Fc+Fa G</td> </tr> <tr> <td style="border: 1px solid black;">F+R+L B</td> <td style="border: 1px solid black;">F/R+Fc M</td> </tr> <tr> <td style="border: 1px solid black;">F+Fc F</td> <td style="border: 1px solid black;">F+Fc1+Fc Q</td> </tr> </table> </div> <div style="border: 1px solid black; padding: 5px; margin-bottom: 5px;"> Bowl type Poly bowl with bowl guard G Metal bowl without sight gauge M* Metal bowl with sight gauge S </div> <div style="font-size: x-small;"> <p>* Not available when using lubricator. Note: All bowl types are the same for each component. Example: If a "G" is specified for a F+L, both units would get a poly bowl with bowl guard.</p> </div> | F/R+L A | F+Fc+Fa G | F+R+L B | F/R+Fc M | F+Fc F | F+Fc1+Fc Q | <div style="border: 1px solid black; padding: 5px; margin-bottom: 5px;"> Element 0.01µ Element C 0.01µ Element with dpi D* 5µ Element E 5µ Element with dpi F* 1µ Element 9 1µ Element with dpi Q* Adsorber A </div> <div style="border: 1px solid black; padding: 5px; margin-bottom: 5px;"> Drain type Auto drain A Manual drain M </div> | <div style="border: 1px solid black; padding: 5px; margin-bottom: 5px;"> Relief / Adjustment Non-rising knob relieving N </div> <div style="border: 1px solid black; padding: 5px; margin-bottom: 5px;"> Adjustment range With round gauge 2 bar; 30 psig; 0.2 MPa Z 4 bar; 60 psig; 0.4 MPa M 8 bar; 125 psig; 0.8 MPa G 17 bar; 250 psig; 1.7 MPa J* Without gauge 2 bar; 30 psig; 0.2 MPa Y 4 bar; 60 psig; 0.4 MPa L 8 bar; 125 psig; 0.8 MPa N 17 bar; 250 psig; 1.7 MPa H* </div> <div style="font-size: x-small;"> <p>* Not available with poly bowl with bowl guard.</p> </div> | <div style="border: 1px solid black; padding: 5px; margin-bottom: 5px;"> Lub type Oil mist standard sight dome L </div> <div style="border: 1px solid black; padding: 5px; margin-bottom: 5px;"> Drain type No drain; closed end N </div> | <div style="border: 1px solid black; padding: 5px; margin-bottom: 5px;"> Mounting No bracket A Port blocks C Port blocks & wall brkt D Wall bracket W </div> |
| F/R+L A | F+Fc+Fa G | | | | | | | | | |
| F+R+L B | F/R+Fc M | | | | | | | | | |
| F+Fc F | F+Fc1+Fc Q | | | | | | | | | |

Popular Combination Dimensions mm (inches)

P31C

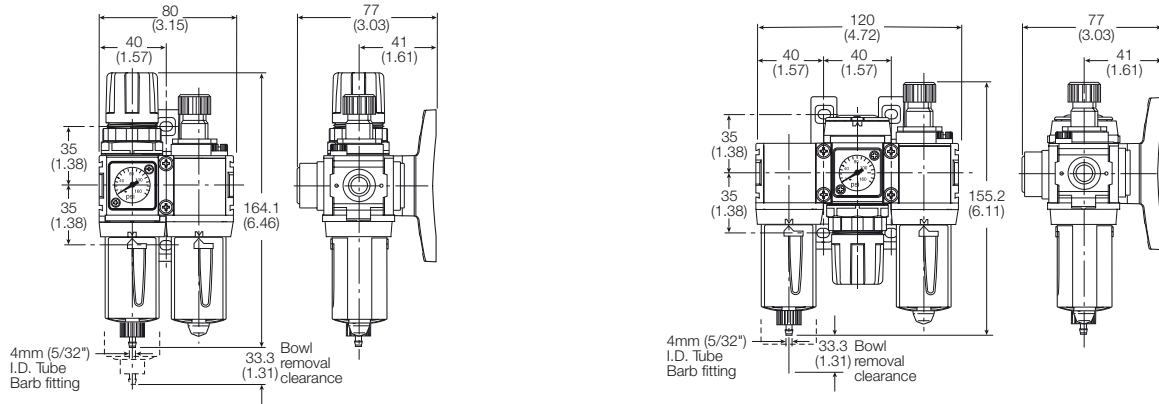

P32C

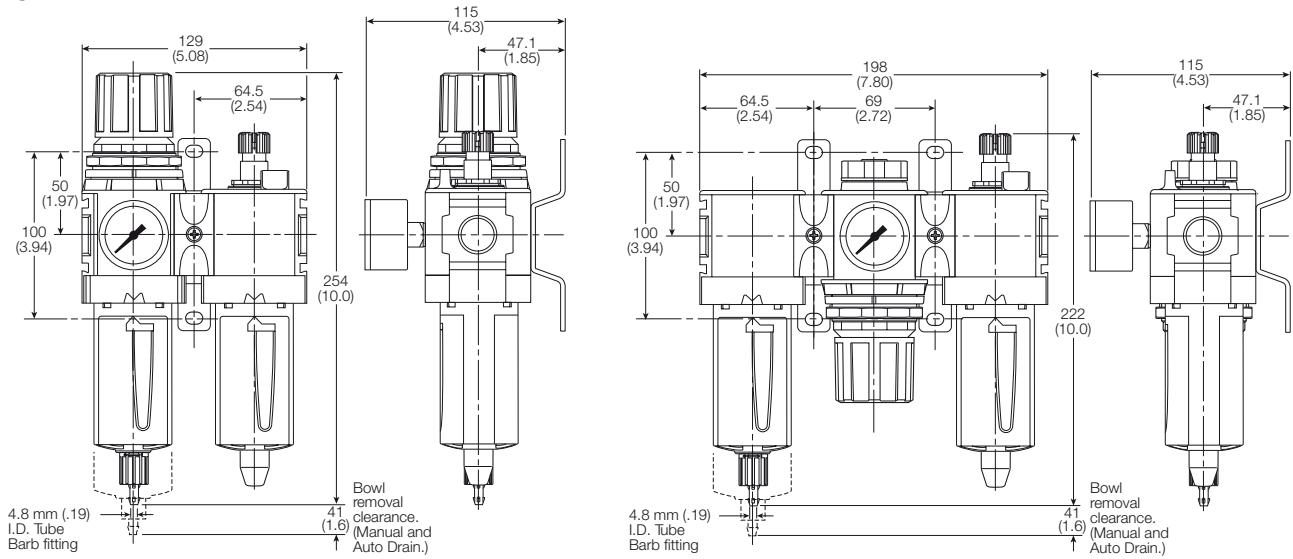

P33C

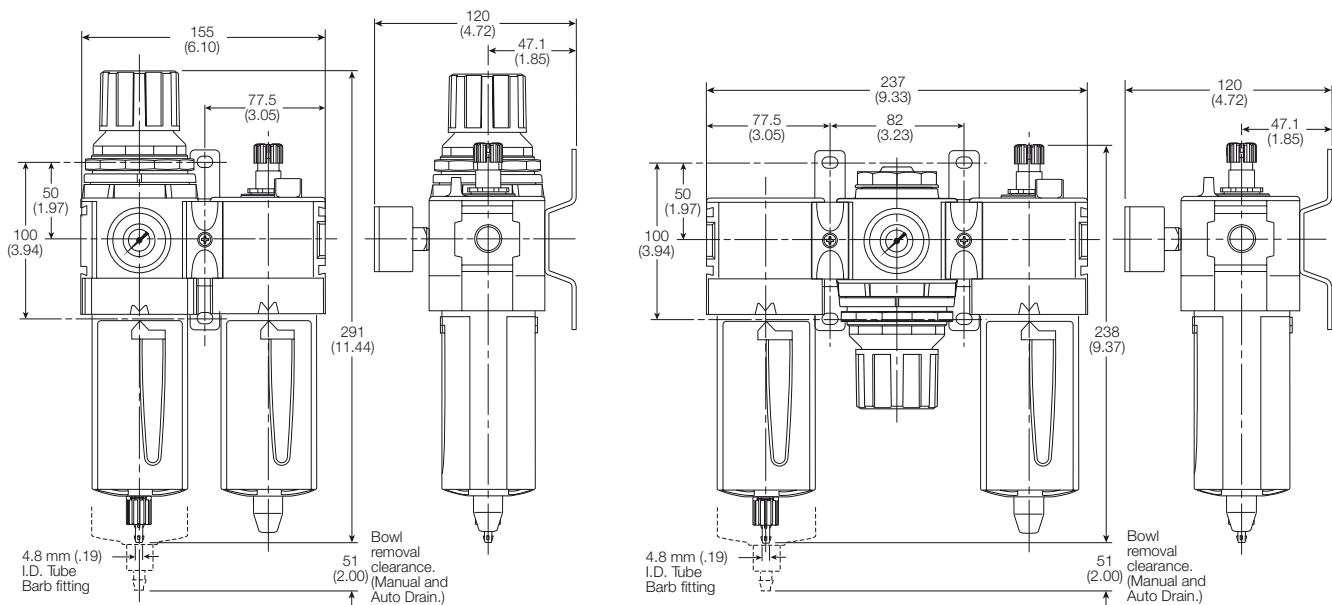

Global Air Preparation System

Mini Particulate Filter - P31



Symbols

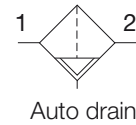
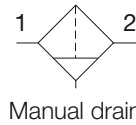

- Integral 1/4" ports (NPT, BSPP & BSPT)
- High efficiency 5 micron element as standard
- Excellent water removal efficiency
- Robust but lightweight aluminum construction
- One hand operation for easy element cartridge removal
- Positive bayonet latch to ensure correct & safe fitting

Options:

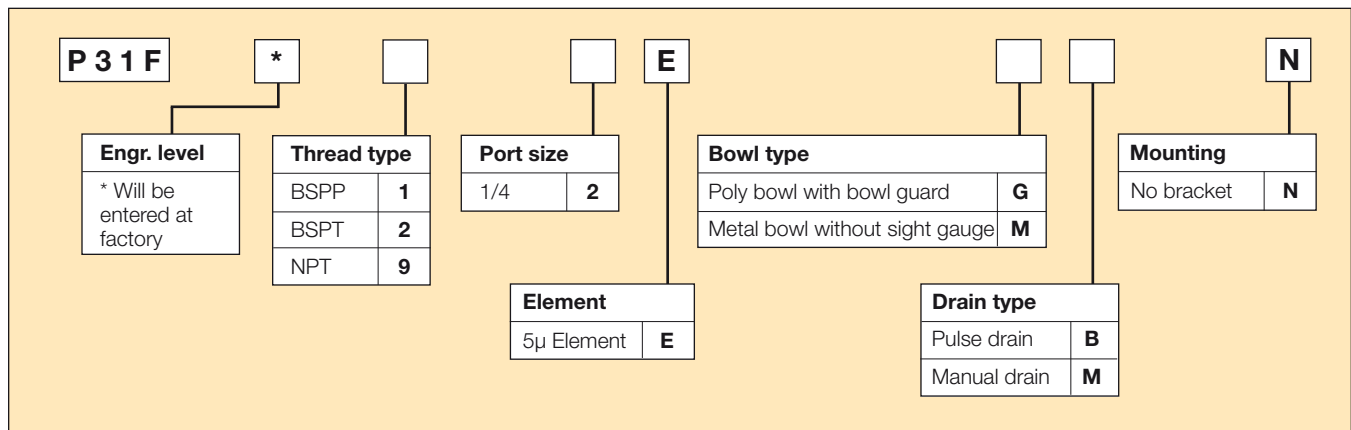

* Engineering Level will be entered at factory.

| Port size | Description | Order Code† | Flow‡ dm ³ /s (scfm) | Max. bar (psig) | Height mm (inches) | Width mm (inches) | Depth mm (inches) |
|-----------|---------------------------|--------------------|------------------------------------|-----------------|-----------------------|----------------------|----------------------|
| 1/4" | Poly bowl - Manual drain | P31F*92EGMN | 12 (25) | 10 (150) | 116.3 (4.58) | 40 (1.58) | 42.7 (1.68) |
| 1/4" | Poly bowl - Pulse drain | P31F*92EGBN | 12 (25) | 10 (150) | 116.3 (4.58) | 40 (1.58) | 42.7 (1.68) |
| 1/4" | Metal bowl - Manual drain | P31F*92EMMN | 12 (25) | 17 (250) | 116.3 (4.58) | 40 (1.58) | 42.7 (1.68) |
| 1/4" | Metal bowl - Pulse drain | P31F*92EMBN | 12 (25) | 17 (250) | 116.3 (4.58) | 40 (1.58) | 42.7 (1.68) |

† Standard part numbers shown in bold. For other models refer to Options chart above.

‡ Flow with 6.3 bar (91.3 psig) inlet pressure and 0.34 (4.9 psig) pressure drop.

Global Air Preparation System

Specifications

| | | |
|-----------------------|-----------------------|---------------------------------|
| Flow Capacity* | 1/4 | 12 dm ³ /s (25 scfm) |
| Operating Temperature | Plastic Bowl | -10°C to 52°C (14°F to 125°F) |
| | Metal Bowl | -10°C to 65.5°C (14°F to 150°F) |
| Max. Supply Pressure | Plastic Bowl | 10 bar (150 psig) |
| | Metal Bowl | 17 bar (250 psig) |
| Standard Filtration | | 5 Micron |
| Useful Retention† | | 12 cm ³ (0.4 US oz.) |
| Port Size | BSPP / BSPT / NPT 1/4 | |
| Weight | | 0.11 kg (0.24 lbs) |

* Inlet pressure 6.3 bar (91.3 psig). Pressure drop 0.34 bar (4.9 psig).
 † Useful retention refers to volume below the quiet zone baffle.

Air quality:

Within ISO 8573-1: 1991 Class 3 (Particulates)
 Within ISO 8573-1: 2001 Class 6 (Particulates)

Materials of Construction

| | |
|------------------|-----------------------|
| Body | Aluminum |
| Body Cap | ABS |
| Bowl | Polycarbonate |
| Bowl Guard | Nylon |
| Element Retainer | Acetal |
| Baffle | Acetal |
| Filter Element | Sintered Polyethylene |
| Seals | Nitrile |

Flow Charts

1/4 Filter

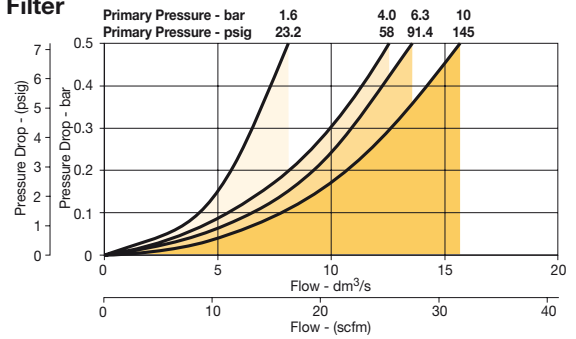

Dimensions mm (inches)

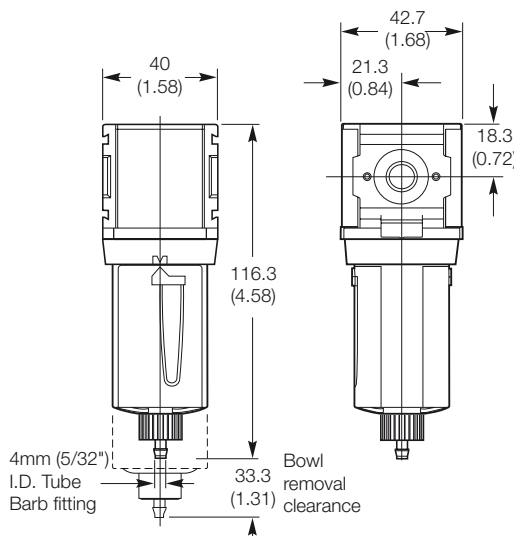

Repair and Service Kits

| | |
|-------------------------------------------|-------------------|
| Plastic bowl / Bowl guard manual drain | P31KA00BGM |
| Metal bowl / w/o sight gauge manual drain | P31KA00BMM |
| Plastic bowl / Bowl guard pulse drain | P31KA00BGB |
| Metal bowl / w/o sight gauge pulse drain | P31KA00BMB |
| 5µ particle filter element | P31KA00ESE |
| C-Bracket (fits to body) | P31KA00MW |
| T-Bracket with body connector | P31KA00MT |
| Body connector | P31KA00CB |

Global Air Preparation System

Compact Particulate Filter - P32



Symbols

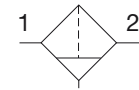

Manual drain

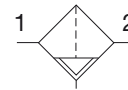

Auto drain

- Integral 1/4", 3/8" or 1/2" ports (NPT, BSPP & BSPT)
- High efficiency 5 micron element as standard
- Excellent water removal efficiency
- Robust but lightweight aluminum construction
- Positive bayonet latch to ensure correct & safe fitting

Options:

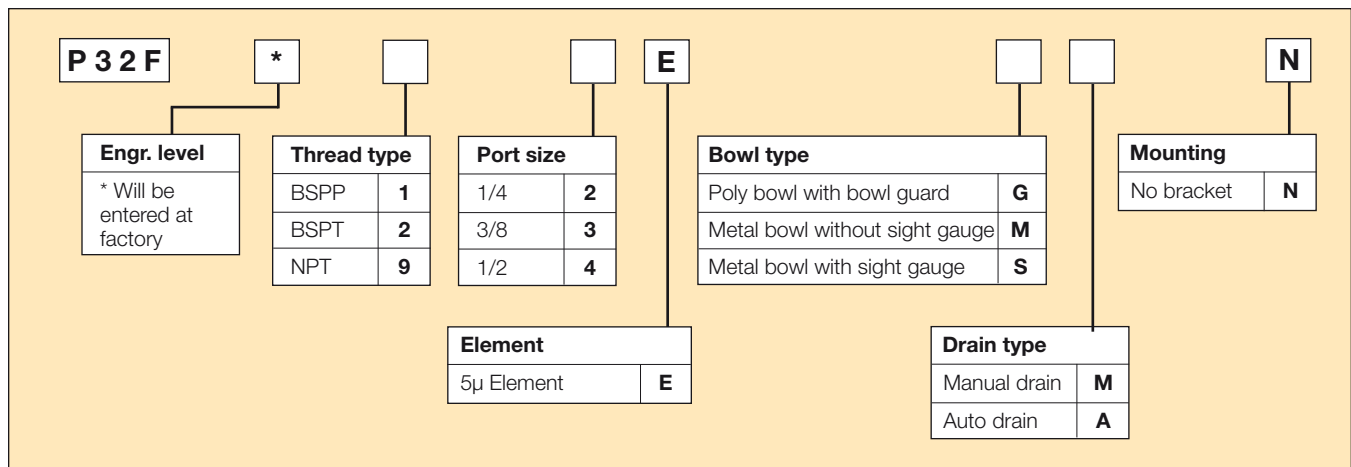

* Engineering Level will be entered at factory.

| Port size | Description | Order Code† | Flow‡ dm ³ /s (scfm) | Max. bar (psig) | Height mm (inches) | Width mm (inches) | Depth mm (inches) |
|-----------|---------------------------|--------------------|------------------------------------|--------------------|-----------------------|----------------------|----------------------|
| 1/4" | Poly bowl - Manual drain | P32F*92EGMN | 18 (38) | 10 (150) | 188 (7.4) | 60 (2.36) | 60 (2.36) |
| 1/4" | Poly bowl - Auto drain | P32F*92EG*N | 18 (38) | 10 (150) | 182 (7.2) | 60 (2.36) | 60 (2.36) |
| 1/4" | Metal bowl - Manual drain | P32F*92ESMN | 18 (38) | 17 (250) | 188 (7.4) | 60 (2.36) | 60 (2.36) |
| 1/4" | Metal bowl - Auto drain | P32F*92ES*N | 18 (38) | 17 (250) | 182 (7.2) | 60 (2.36) | 60 (2.36) |
| 3/8" | Poly bowl - Manual drain | P32F*93EGMN | 30 (64) | 10 (150) | 188 (7.4) | 60 (2.36) | 60 (2.36) |
| 3/8" | Poly bowl - Auto drain | P32F*93EG*N | 30 (64) | 10 (150) | 182 (7.2) | 60 (2.36) | 60 (2.36) |
| 3/8" | Metal bowl - Manual drain | P32F*93ESMN | 30 (64) | 17 (250) | 188 (7.4) | 60 (2.36) | 60 (2.36) |
| 3/8" | Metal bowl - Auto drain | P32F*93ES*N | 30 (64) | 17 (250) | 182 (7.2) | 60 (2.36) | 60 (2.36) |
| 1/2" | Poly bowl - Manual drain | P32F*94EGMN | 38 (80) | 10 (150) | 188 (7.4) | 60 (2.36) | 60 (2.36) |
| 1/2" | Poly bowl - Auto drain | P32F*94EG*N | 38 (80) | 10 (150) | 182 (7.2) | 60 (2.36) | 60 (2.36) |
| 1/2" | Metal bowl - Manual drain | P32F*94ESMN | 38 (80) | 17 (250) | 188 (7.4) | 60 (2.36) | 60 (2.36) |
| 1/2" | Metal bowl - Auto drain | P32F*94ES*N | 38 (80) | 17 (250) | 182 (7.2) | 60 (2.36) | 60 (2.36) |

† Standard part numbers shown in bold. For other models refer to Options chart above.

‡ Flow with 6.3 bar (91.3 psig) inlet pressure and 0.34 (4.9 psig) pressure drop.



Global Air Preparation System

Specifications

| | | |
|-----------------------|-------------------|----------------------------------|
| Flow Capacity* | 1/4 | 18 dm ³ /s (38 scfm) |
| | 3/8 | 30 dm ³ /s (64 scfm) |
| | 1/2 | 38 dm ³ /s (80 scfm) |
| Operating Temperature | Plastic Bowl | -25°C to 52°C (-13°F to 125°F) |
| | Metal Bowl | -25°C to 65.5°C (-13°F to 150°F) |
| Max. Supply Pressure | Plastic Bowl | 10 bar (150 psig) |
| | Metal Bowl | 17 bar (250 psig) |
| Standard Filtration | | 5 Micron |
| Useful Retention† | | 51 cm ³ (1.7 US oz.) |
| Port Size | BSPP / BSPT / NPT | 1/4, 3/8, 1/2 |
| Weight | | 0.28 kg (0.62 lbs) |

* Inlet pressure 6.3 bar (91.3 psig). Pressure drop 0.34 bar (4.9 psig).
 † Useful retention refers to volume below the quiet zone baffle.

Air quality:

Within ISO 8573-1: 1991 Class 3 (Particulates)
 Within ISO 8573-1: 2001 Class 6 (Particulates)

Materials of Construction

| | | |
|---------------------------|-----------------------|---------------|
| Body | Aluminum | |
| Body Cap | ABS | |
| Bowls | Plastic Bowl | Polycarbonate |
| | Metal Bowl | Aluminum |
| Bowl Guard | Nylon | |
| Deflector | Polypropylene | |
| Element Retainer / Baffle | Acetal | |
| Filter Element | Sintered Polyethylene | |
| Seals | Nitrile | |
| Sight Gauge | Metal Bowl | Polycarbonate |

Dimensions mm (inches)

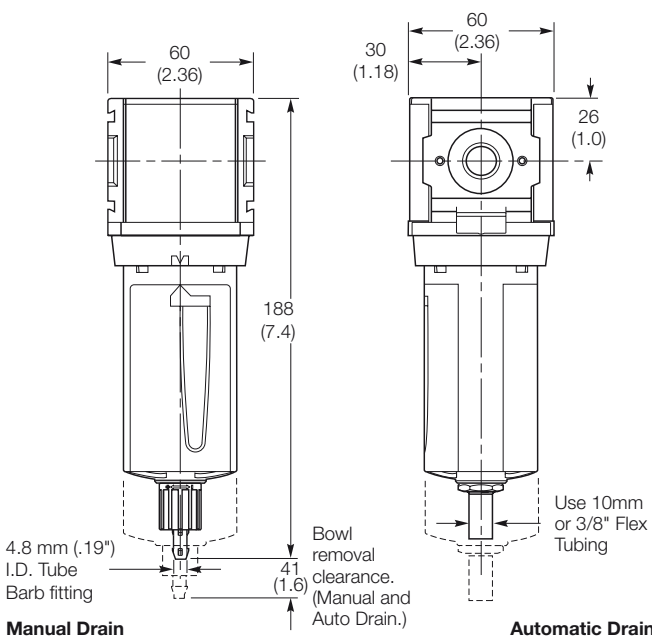

Flow Charts

1/4 Filter

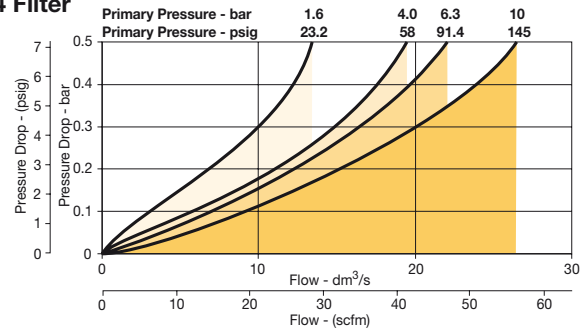

3/8 Filter

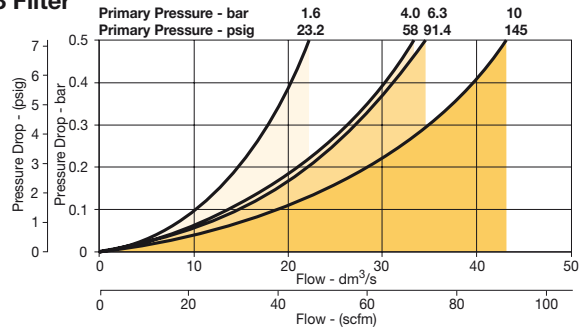

1/2 Filter

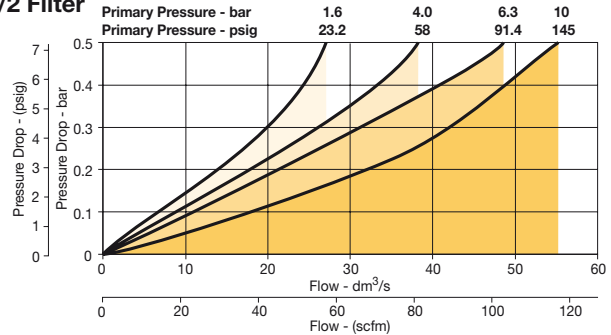

Repair and Service Kits

| | |
|-----------------------------------------------|-------------------|
| Plastic bowl / Bowl guard manual drain | P32KA00BGM |
| Metal bowl / Sight gauge manual drain | P32KA00BSM |
| Auto drain | P32KA00DA |
| 5µ particle filter element | P32KA00ESE |
| L-Bracket (fits to body) | P32KA00ML |
| T-Bracket (fits to body connector) | P32KA00MB |
| T-Bracket with body connector | P32KA00MT |
| Body connector | P32KA00CB |
| Differential pressure indicator (replacement) | P32KA00RQ |

Global Air Preparation System

Standard Particulate Filter - P33



Symbols

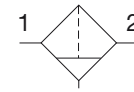

Manual drain

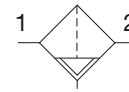

Auto drain

- Integral 1/2" or 3/4" ports (NPT, BSPP & BSPT)
- High efficiency 5 micron element as standard
- Excellent water removal efficiency
- Robust but lightweight aluminum construction
- Positive bayonet latch to ensure correct & safe fitting

Options:

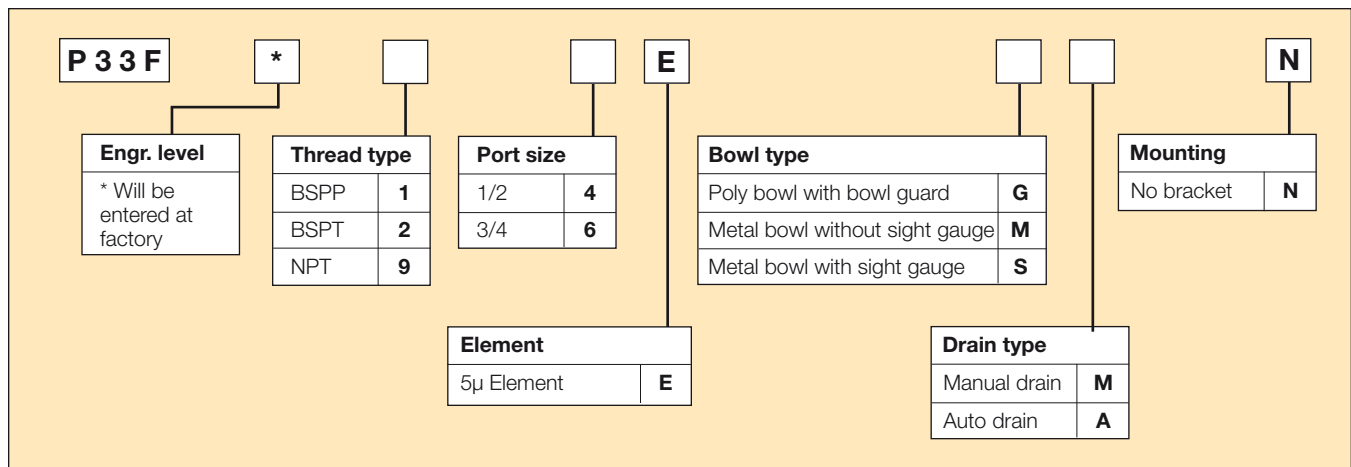

* Engineering Level will be entered at factory.

| Port size | Description | Order Code† | Flow‡ dm ³ /s (scfm) | Max. bar (psig) | Height mm (inches) | Width mm (inches) | Depth mm (inches) |
|-----------|---------------------------|--------------------|------------------------------------|--------------------|-----------------------|----------------------|----------------------|
| 1/2" | Poly bowl - Manual drain | P33F*94EGMN | 40 (85) | 10 (150) | 213 (8.4) | 73 (2.9) | 73 (2.9) |
| 1/2" | Poly bowl - Auto drain | P33F*94EG*N | 40 (85) | 10 (150) | 207 (8.2) | 73 (2.9) | 73 (2.9) |
| 1/2" | Metal bowl - Manual drain | P33F*94ESMN | 40 (85) | 17 (250) | 213 (8.4) | 73 (2.9) | 73 (2.9) |
| 1/2" | Metal bowl - Auto drain | P33F*94ES*N | 40 (85) | 17 (250) | 207 (8.2) | 73 (2.9) | 73 (2.9) |
| 3/4" | Poly bowl - Manual drain | P33F*96EGMN | 48 (102) | 10 (150) | 213 (8.4) | 73 (2.9) | 73 (2.9) |
| 3/4" | Poly bowl - Auto drain | P33F*96EG*N | 48 (102) | 10 (150) | 207 (8.2) | 73 (2.9) | 73 (2.9) |
| 3/4" | Metal bowl - Manual drain | P33F*96ESMN | 48 (102) | 17 (250) | 213 (8.4) | 73 (2.9) | 73 (2.9) |
| 3/4" | Metal bowl - Auto drain | P33F*96ES*N | 48 (102) | 17 (250) | 207 (8.2) | 73 (2.9) | 73 (2.9) |

† Standard part numbers shown in bold. For other models refer to Options chart above.

‡ Flow with 6.3 bar (91.3 psig) inlet pressure and 0.34 (4.9 psig) pressure drop.

Global Air Preparation System

Specifications

| | | |
|-----------------------|---------------------------------|----------------------------------|
| Flow Capacity* | 1/2 | 40 dm ³ /s (85 scfm) |
| | 3/4 | 48 dm ³ /s (102 scfm) |
| Operating Temperature | Plastic Bowl | -25°C to 52°C (-13°F to 125°F) |
| | Metal Bowl | -25°C to 65.5°C (-13°F to 150°F) |
| Max. Supply Pressure | Plastic Bowl | 10 bar (150 psig) |
| | Metal Bowl | 17 bar (250 psig) |
| Standard Filtration | 5 Micron | |
| Useful Retention† | 85 cm ³ (2.8 US oz.) | |
| Port Size | BSPP / BSPT / NPT 1/2, 3/4 | |
| Weight | 0.46 kg (1.01 lbs) | |

* Inlet pressure 6.3 bar (91.3 psig). Pressure drop 0.34 bar (4.9 psig).

† Useful retention refers to volume below the quiet zone baffle.

Air quality:

Within ISO 8573-1: 1991 Class 3 (Particulates)

Within ISO 8573-1: 2001 Class 6 (Particulates)

Materials of Construction

| | | |
|---------------------------|-----------------------|---------------|
| Body | Aluminum | |
| Body Cap | ABS | |
| Bowls | Plastic Bowl | Polycarbonate |
| | Metal Bowl | Aluminum |
| Bowl Guard | Nylon | |
| Deflector | Polypropylene | |
| Element Retainer / Baffle | Acetal | |
| Filter Element | Sintered Polyethylene | |
| Seals | Nitrile | |
| Sight Gauge | Metal Bowl | Polycarbonate |

Dimensions mm (inches)

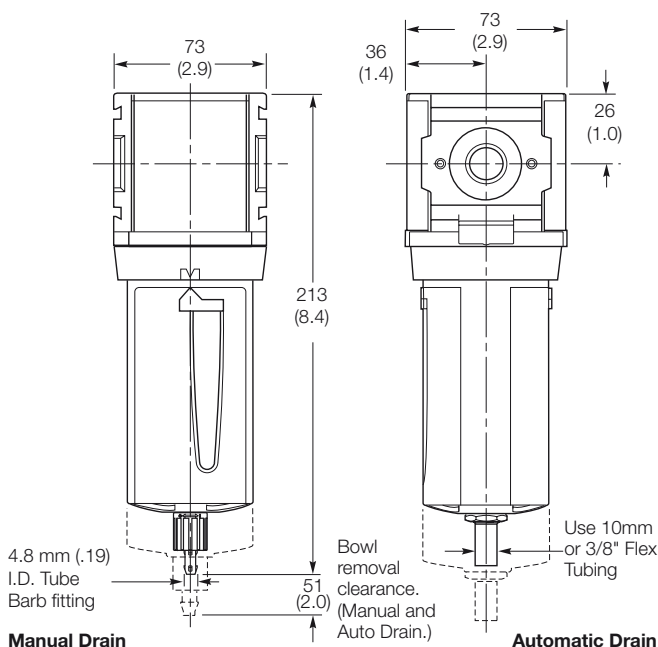

Flow Charts

1/2 Filter

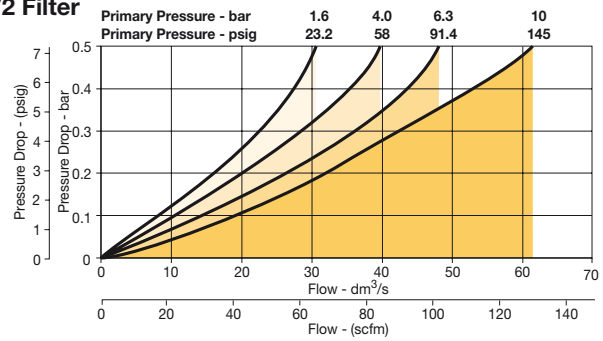

3/4 Filter

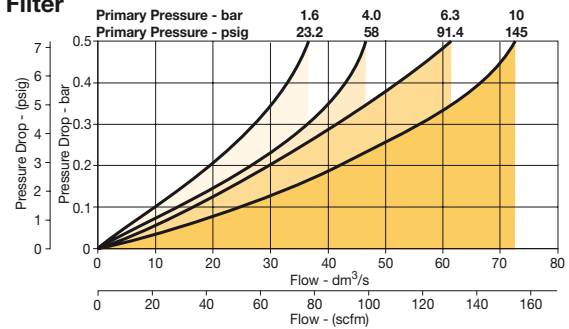

Repair and Service Kits

| | |
|-----------------------------------------------|-------------------|
| Plastic bowl / Bowl guard manual drain | P33KA00BGM |
| Metal bowl / Sight gauge manual drain | P33KA00BSM |
| Auto drain | P32KA00DA |
| 5µ particle filter element | P33KA00ESE |
| L-Bracket (fits to body) | P33KA00ML |
| T-Bracket (fits to body connector) | P32KA00MB |
| T-Bracket with body connector | P33KA00MT |
| Body connector | P32KA00CB |
| Differential pressure indicator (replacement) | P32KA00RQ |

Global Air Preparation System

Mini Coalescing and Adsorber Filters - P31



- Integral 1/4" ports (NPT, BSPP & BSPT)
- Removes liquid aerosols and sub micron particles
- Oil free air for critical applications, such as air gauging, pneumatic instrumentation and control
- Positive bayonet latch to ensure correct & safe fitting
- Adsorbing activated carbon element removes oil vapors and most hydrocarbons

Note: To optimize the life of coalescing element, it is advisable to install a P31F pre-filter with a 5 micron element upstream of the coalescing filter.

To optimize the life of an Adsorber it is advisable to install a P31 Coalescing Filter upstream of the Adsorber. Adsorber element should be replaced approximately every 1000 hours of service.

Options:

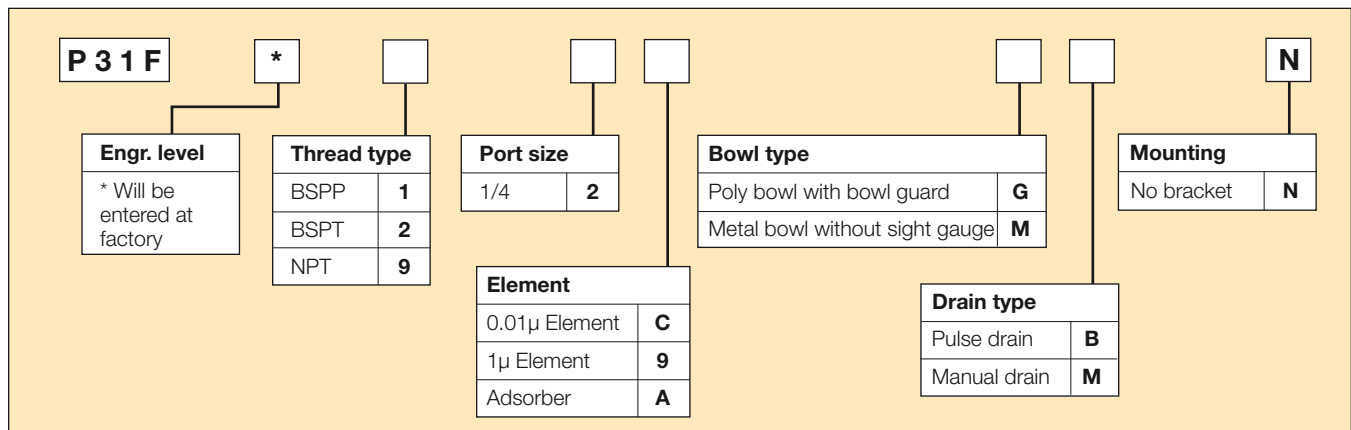

* Engineering Level will be entered at factory.

| Port size | Description | Order Code† | Flow‡ dm ³ /s (scfm) | Max. bar (psig) | Height mm (inches) | Width mm (inches) | Depth mm (inches) |
|-----------|-----------------------------------------|--------------------|------------------------------------|--------------------|-----------------------|----------------------|----------------------|
| 1/4" | Poly bowl - 0.01 micron - Manual drain | P31F*92CGMN | 2 (4.2) | 10 (150) | 116.3 (4.58) | 40 (1.58) | 42.7 (1.68) |
| 1/4" | Poly bowl - 0.01 micron - Pulse drain | P31F*92CGBN | 2 (4.2) | 10 (150) | 116.3 (4.58) | 40 (1.58) | 42.7 (1.68) |
| 1/4" | Metal bowl - 0.01 micron - Manual drain | P31F*92CMMN | 2 (4.2) | 17 (250) | 116.3 (4.58) | 40 (1.58) | 42.7 (1.68) |
| 1/4" | Metal bowl - 0.01 micron - Pulse drain | P31F*92CMBN | 2 (4.2) | 17 (250) | 116.3 (4.58) | 40 (1.58) | 42.7 (1.68) |

† Standard part numbers shown in bold. For other models refer to Options chart above.

‡ Flow with 6.3 bar (91.3 psig) inlet pressure and 0.2 (3 psig) pressure drop.

Global Air Preparation System

Specifications

| | | | |
|---------------------------|------------------------------|---------------------------------|-------|
| Flow Capacity | | dm ³ /s | SCFM |
| 1.0 Micron Coalescing | Energy Efficient Flow* | 3.8 | (8) |
| | Maximum Flow** | 6 | (13) |
| 0.01 Micron Coalescing | Energy Efficient Flow* | 2 | (4.2) |
| | Maximum Flow** | 3.8 | (8) |
| Activated Carbon Adsorber | Rated Flow* | 6 | (13) |
| Operating Temperature | Plastic Bowl | -10°C to 52°C (14°F to 125°F) | |
| | Metal Bowl | -10°C to 65.5°C (14°F to 150°F) | |
| Max. Supply Pressure | Plastic Bowl | 10 bar (150 psig) | |
| | Metal Bowl | 17 bar (250 psig) | |
| Standard Filtration | | 1.0 and 0.01 Micron | |
| Adsorber | Max. oil carryover (ppm w/w) | 0.003 @ 21°C (70°F) | |
| Useful Retention† | | 12 cm ³ (0.4 US oz.) | |
| Port Size | BSPP / BSPT / NPT | 1/4 | |
| Weight | | 0.11 kg (0.24 lbs) | |

* Inlet pressure 6.3 bar (91.3 psig), Pressure drop 0.2 bar (3 psig), Saturated Element.

** Inlet pressure 6.3 bar (91.3 psig), Pressure drop 0.4 bar (6 psig), Saturated Element.

† Useful retention refers to volume below the quiet zone baffle.

Materials of Construction

| | | |
|----------------|--------------------|--------------------|
| Body | Aluminum | |
| Body Cap | ABS | |
| Bowl | Plastic Bowl | Polycarbonate |
| | Metal Bowl | Aluminum |
| Filter Element | 1.0 and .01 Micron | Borosilicate Cloth |
| Adsorber | Activated Carbon | |
| Seals | Nitrile | |

Dimensions mm (inches)

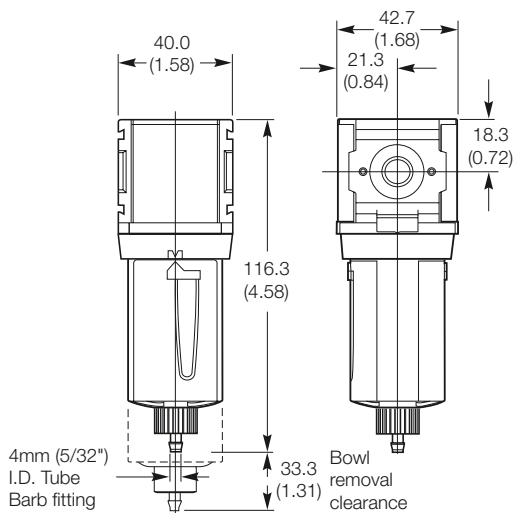

Flow Charts

P31 - 1.0 micron flow

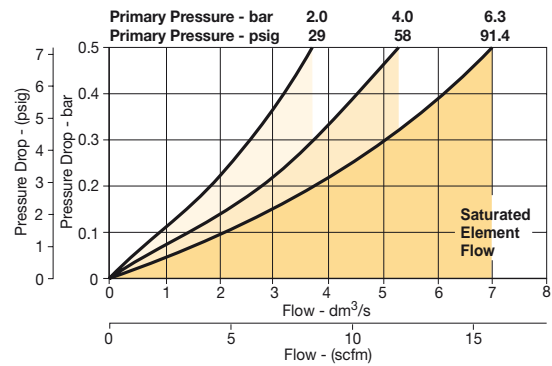

P31 - 0.01 micron flow

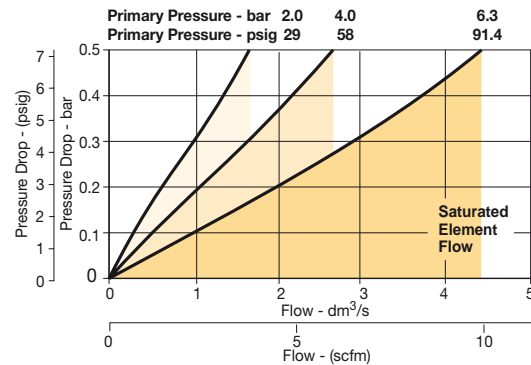

Repair and Service Kits

| | |
|-------------------------------------------|-------------------|
| Plastic bowl / Bowl guard manual drain | P31KA00BGM |
| Metal bowl / w/o sight gauge manual drain | P31KA00BMM |
| Plastic bowl / Bowl guard pulse drain | P31KA00BGB |
| Metal bowl / w/o sight gauge pulse drain | P31KA00BMB |
| 1µ coalescing filter element | P31KA00ES9 |
| 0.01µ coalescing filter element | P31KA00ESC |
| Activated carbon adsorber filter element | P31KA00ESA |
| C-Bracket (fits to body) | P31KA00MW |
| T-Bracket with body connector | P31KA00MT |
| Body connector | P31KA00CB |

Global Air Preparation System

Compact Coalescing and Adsorber Filter - P32



- Integral 1/4", 3/8" or 1/2" ports (NPT, BSPP & BSPT)
- Removes liquid aerosols and sub micron particles
- Oil free air for critical applications, such as air gauging, pneumatic instrumentation and control
- Differential Pressure Indicator (DPI) standard on Coalescing Filters
- Positive bayonet latch to ensure correct & safe fitting
- Adsorbing activated carbon element removes oil vapors and most hydrocarbons

Note: To optimize the life of coalescing element, it is advisable to install a P32F pre-filter with a 5 micron element upstream of the coalescing filter.

To optimize the life of an Adsorber it is advisable to install a P32 Coalescing Filter upstream of the Adsorber. Adsorber element should be replaced approximately every 1000 hours of service.

Options:

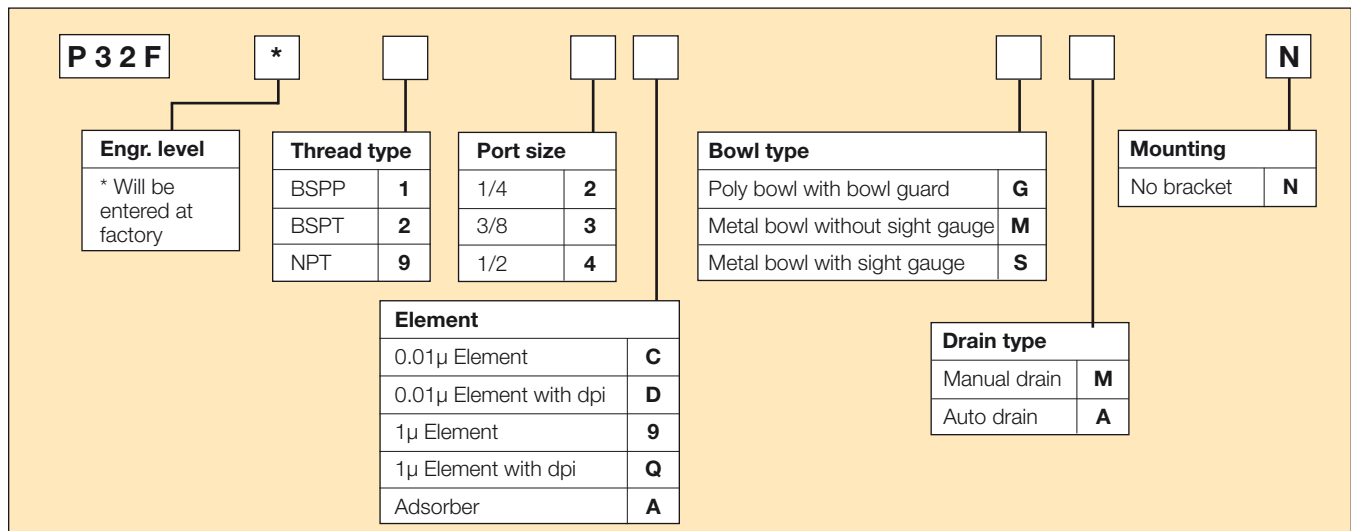

* Engineering Level will be entered at factory.

| Port size | Description | Order Code† | Flow‡ dm ³ /s (scfm) | Max. bar (psig) | Height mm (inches) | Width mm (inches) | Depth mm (inches) |
|-----------|----------------------------------------|--------------------|------------------------------------|-----------------|-----------------------|----------------------|----------------------|
| 1/4" | Poly bowl - 0.01 Micron, Manual drain | P32F*92DGMN | 11 (23) | 10 (150) | 209 (8.2) | 60 (2.36) | 60 (2.36) |
| 1/4" | Poly bowl - 0.01 Micron, Auto drain | P32F*92DGAN | 11 (23) | 10 (150) | 203 (8.0) | 60 (2.36) | 60 (2.36) |
| 1/4" | Metal bowl - 0.01 Micron, Manual drain | P32F*92DSMN | 11 (23) | 17 (250) | 209 (8.2) | 60 (2.36) | 60 (2.36) |
| 1/4" | Metal bowl - 0.01 Micron, Auto drain | P32F*92DSAN | 11 (23) | 17 (250) | 203 (8.0) | 60 (2.36) | 60 (2.36) |
| 3/8" | Poly bowl - 0.01 Micron, Manual drain | P32F*93DGMN | 11 (23) | 10 (150) | 209 (8.2) | 60 (2.36) | 60 (2.36) |
| 3/8" | Poly bowl - 0.01 Micron, Auto drain | P32F*93DGAN | 11 (23) | 10 (150) | 203 (8.0) | 60 (2.36) | 60 (2.36) |
| 3/8" | Metal bowl - 0.01 Micron, Manual drain | P32F*93DSMN | 11 (23) | 17 (250) | 209 (8.2) | 60 (2.36) | 60 (2.36) |
| 3/8" | Metal bowl - 0.01 Micron, Auto drain | P32F*93DSAN | 11 (23) | 17 (250) | 203 (8.0) | 60 (2.36) | 60 (2.36) |
| 1/2" | Poly bowl - 0.01 Micron, Manual drain | P32F*94DGMN | 11 (23) | 10 (150) | 209 (8.2) | 60 (2.36) | 60 (2.36) |
| 1/2" | Poly bowl - 0.01 Micron, Auto drain | P32F*94DGAN | 11 (23) | 10 (150) | 203 (8.0) | 60 (2.36) | 60 (2.36) |
| 1/2" | Metal bowl - 0.01 Micron, Manual drain | P32F*94DSMN | 11 (23) | 17 (250) | 209 (8.2) | 60 (2.36) | 60 (2.36) |
| 1/2" | Metal bowl - 0.01 Micron, Auto drain | P32F*94DSAN | 11 (23) | 17 (250) | 203 (8.0) | 60 (2.36) | 60 (2.36) |

† Standard part numbers shown in bold. For other models refer to Options chart above.

‡ Flow with 6.3 bar (91.3 psig) inlet pressure and 0.2 (3 psig) pressure drop.



Global Air Preparation System

Specifications

| | | | |
|---------------------------|------------------------------|----------------------------------|------|
| Flow Capacity | | dm ³ /s | SCFM |
| 1.0 Micron Coalescing | Energy Efficient Flow* | 17 | (36) |
| | Maximum Flow** | 27 | (57) |
| 0.01 Micron Coalescing | Energy Efficient Flow* | 11 | (23) |
| | Maximum Flow** | 28 | (38) |
| Activated Carbon Adsorber | Rated Flow* | 27 | (57) |
| Operating Temperature | Plastic Bowl | -25°C to 52°C (-13°F to 125°F) | |
| | Metal Bowl | -25°C to 65.5°C (-13°F to 150°F) | |
| Max. Supply Pressure | Plastic Bowl | 10 bar (150 psig) | |
| | Metal Bowl | 17 bar (250 psig) | |
| Standard Filtration | | 1.0 and 0.01 Micron | |
| Adsorber | Max. oil carryover (ppm w/w) | 0.003 @ 21°C (70°F) | |
| Useful Retention† | | 51 cm ³ (1.7 US oz.) | |
| Port Size | BSPP / BSPT / NPT | 1/4, 3/8, 1/2 | |
| Weight | | 0.32 kg (0.71 lbs) | |

* Inlet pressure 6.3 bar (91.3 psig), Pressure drop 0.2 bar (3 psig), Saturated Element.

** Inlet pressure 6.3 bar (91.3 psig), Pressure drop 0.4 bar (6 psig), Saturated Element.

† Useful retention refers to volume below the quiet zone baffle.

Dimensions mm (inches)

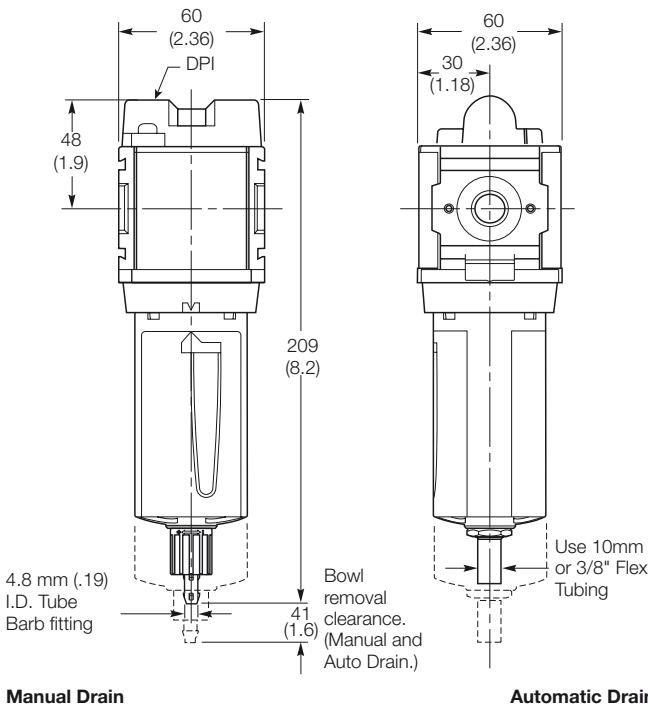

Flow Charts

P32 - 1.0 micron flow

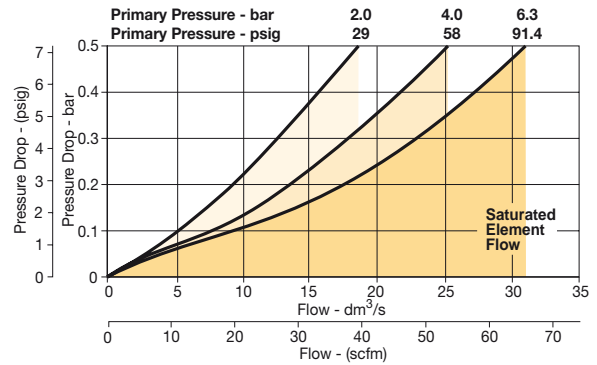

P32 - 0.01 micron flow

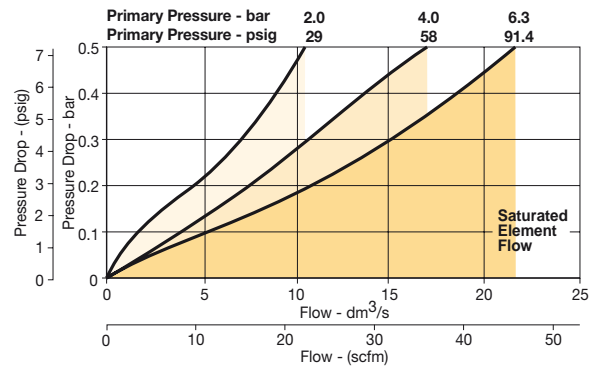

Materials of Construction

| | | |
|----------------|--------------------|--------------------|
| Body | Aluminum | |
| Body Cap | ABS | |
| Bowls | Plastic Bowl | Polycarbonate |
| | Metal Bowl | Aluminum |
| Filter Element | 1.0 and .01 Micron | Borosilicate Cloth |
| Adsorber | Activated Carbon | |
| Seals | Nitrile | |
| Sight Gauge | Metal Bowl | Polycarbonate |

Repair and Service Kits

| | |
|-----------------------------------------------|-------------------|
| Plastic bowl / Bowl guard manual drain | P32KA00BGM |
| Metal bowl / Sight gauge manual drain | P32KA00BSM |
| Auto drain | P32KA00DA |
| 1µ coalescing filter element | P32KA00ES9 |
| 0.01µ coalescing filter element | P32KA00ESC |
| Activated carbon adsorber filter element | P32KA00ESA |
| L-Bracket (fits to body) | P32KA00ML |
| T-Bracket (fits to body connector) | P32KA00MB |
| T-Bracket with body connector | P32KA00MT |
| Body connector | P32KA00CB |
| Differential pressure indicator (replacement) | P32KA00RQ |



Global Air Preparation System

Standard Coalescing and Adsorber Filter - P33



- Integral 1/2" or 3/4" ports (NPT, BSPP & BSPT)
- Removes liquid aerosols and sub micron particles
- Oil free air for critical applications, such as air gauging, pneumatic instrumentation and control
- Differential Pressure Indicator (DPI) standard on Coalescing Filters
- Positive bayonet latch to ensure correct & safe fitting
- Adsorbing activated carbon element removes oil vapors and most hydrocarbons

Note: To optimize the life of coalescing element, it is advisable to install a P33F pre-filter with a 5 micron element upstream of the coalescing filter.

To optimize the life of an Adsorber it is advisable to install a P33 Coalescing Filter upstream of the Adsorber. Adsorber element should be replaced approximately every 1000 hours of service.

Options:

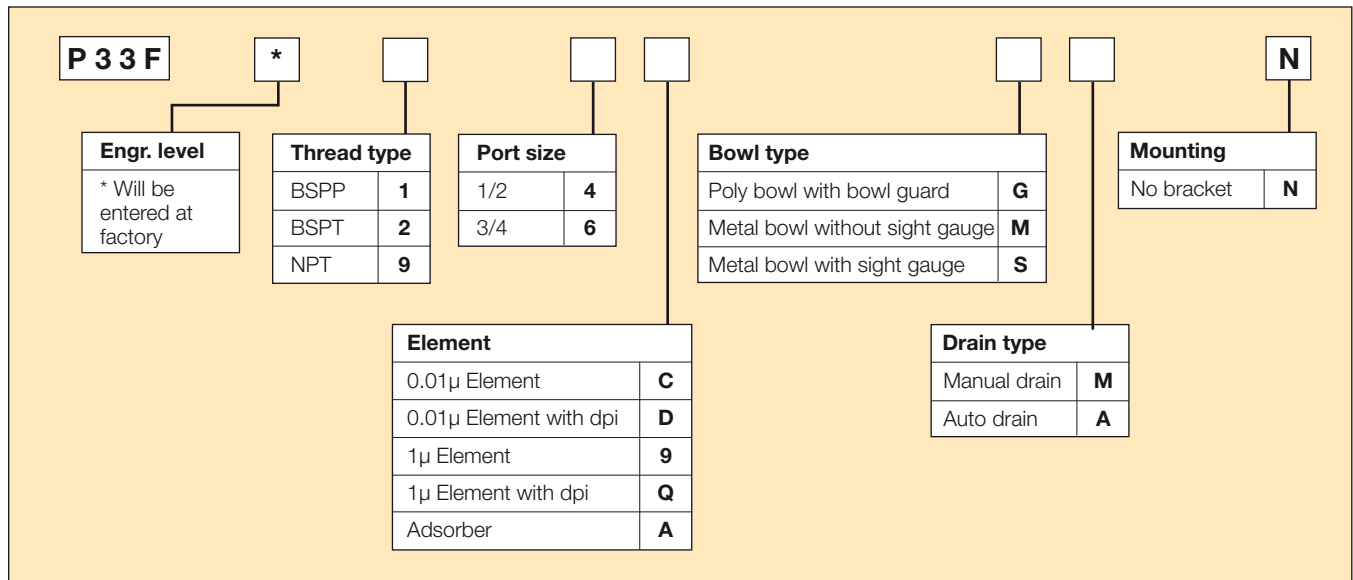

* Engineering Level will be entered at factory.

| Port size | Description | Order Code† | Flow‡ dm ³ /s (scfm) | Max. bar (psig) | Height mm (inches) | Width mm (inches) | Depth mm (inches) |
|-----------|----------------------------------------|--------------------|------------------------------------|--------------------|-----------------------|----------------------|----------------------|
| 1/2" | Poly bowl - 0.01 Micron, Manual drain | P33F*94DGMN | 20 (42) | 10 (150) | 235 (9.3) | 73 (2.9) | 73 (2.9) |
| 1/2" | Poly bowl - 0.01 Micron, Auto drain | P33F*94DGAN | 20 (42) | 10 (150) | 229 (9.0) | 73 (2.9) | 73 (2.9) |
| 1/2" | Metal bowl - 0.01 Micron, Manual drain | P33F*94DSMN | 20 (42) | 17 (250) | 235 (9.3) | 73 (2.9) | 73 (2.9) |
| 1/2" | Metal bowl - 0.01 Micron, Auto drain | P33F*94DSAN | 20 (42) | 17 (250) | 229 (9.0) | 73 (2.9) | 73 (2.9) |
| 3/4" | Poly bowl - 0.01 Micron, Manual drain | P33F*96DGMN | 20 (42) | 10 (150) | 235 (9.3) | 73 (2.9) | 73 (2.9) |
| 3/4" | Poly bowl - 0.01 Micron, Auto drain | P33F*96DGAN | 20 (42) | 10 (150) | 229 (9.0) | 73 (2.9) | 73 (2.9) |
| 3/4" | Metal bowl - 0.01 Micron, Manual drain | P33F*96DSMN | 20 (42) | 17 (250) | 235 (9.3) | 73 (2.9) | 73 (2.9) |
| 3/4" | Metal bowl - 0.01 Micron, Auto drain | P33F*96DSAN | 20 (42) | 17 (250) | 229 (9.0) | 73 (2.9) | 73 (2.9) |

† Standard part numbers shown in bold. For other models refer to Options chart above.

‡ Flow with 6.3 bar (91.3 psig) inlet pressure and 0.2 (3 psig) pressure drop.



Global Air Preparation System

Specifications

| | | | |
|---------------------------|------------------------------|----------------------------------|------|
| Flow Capacity | | dm ³ /s | SCFM |
| 1.0 Micron Coalescing | Energy Efficient Flow* | 32 | (68) |
| | Maximum Flow** | 44 | (93) |
| 0.01 Micron Coalescing | Energy Efficient Flow* | 20 | (42) |
| | Maximum Flow** | 34 | (72) |
| Activated Carbon Adsorber | Rated Flow* | 44 | (93) |
| Operating Temperature | Plastic Bowl | -25°C to 52°C (-13°F to 125°F) | |
| | Metal Bowl | -25°C to 65.5°C (-13°F to 150°F) | |
| Max. Supply Pressure | Plastic Bowl | 10 bar (150 psig) | |
| | Metal Bowl | 17 bar (250 psig) | |
| Standard Filtration | | 1.0 and 0.01 Micron | |
| Adsorber | Max. oil carryover (ppm w/w) | 0.003 @ 21°C (70°F) | |
| Useful Retention† | | 85 cm ³ (2.8 US oz.) | |
| Port Size | BSPP / BSPT / NPT | 1/2, 3/4 | |
| Weight | | 0.50 kg (1.10 lbs) | |

* Inlet pressure 6.3 bar (91.3 psig), Pressure drop 0.2 bar (3 psig), Saturated Element.

** Inlet pressure 6.3 bar (91.3 psig), Pressure drop 0.4 bar (6 psig), Saturated Element.

† Useful retention refers to volume below the quiet zone baffle.

Dimensions mm (inches)

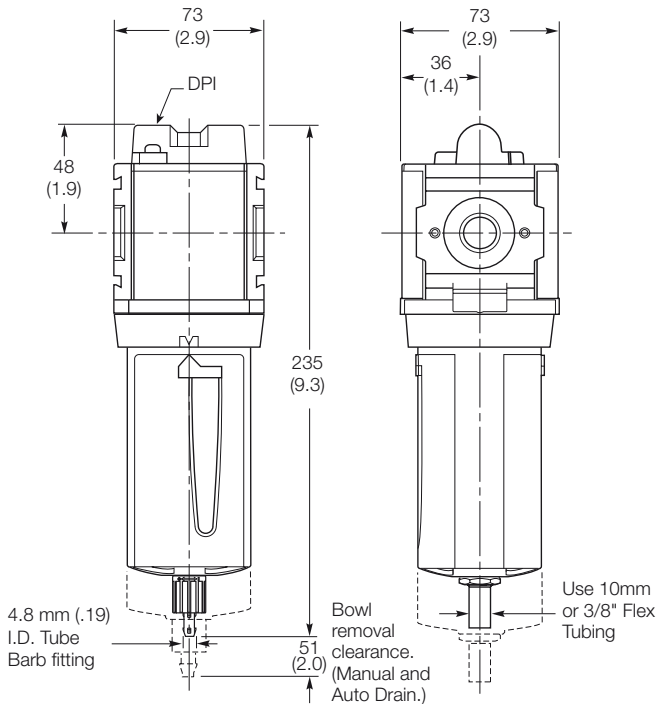

Manual Drain

Automatic Drain

Flow Charts

P33 - 1.0 micron flow

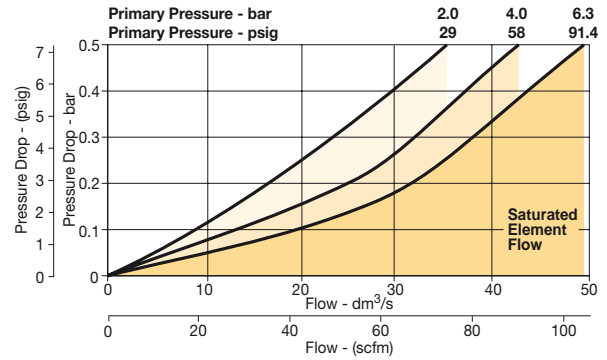

P33 - 0.01 micron flow

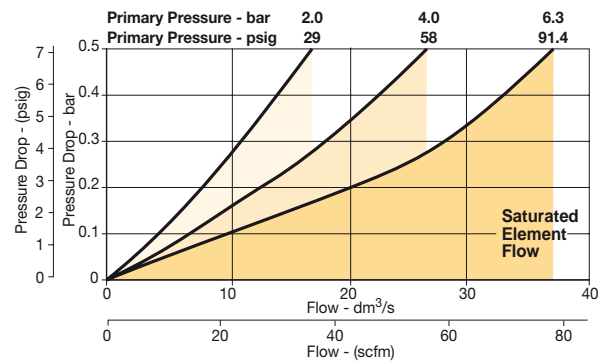

Materials of Construction

| | | |
|----------------|--------------------|--------------------|
| Body | Aluminum | |
| Body Cap | ABS | |
| Bowls | Plastic Bowl | Polycarbonate |
| | Metal Bowl | Aluminum |
| Filter Element | 1.0 and .01 Micron | Borosilicate Cloth |
| Adsorber | Activated Carbon | |
| Seals | Nitrile | |
| Sight Gauge | Metal Bowl | Polycarbonate |

Repair and Service Kits

| | |
|-----------------------------------------------|-------------------|
| Plastic bowl / Bowl guard manual drain | P33KA00BGM |
| Metal bowl / Sight gauge manual drain | P33KA00BSM |
| Auto drain | P32KA00DA |
| 1µ coalescing filter element | P33KA00ES9 |
| 0.01µ coalescing filter element | P33KA00ESC |
| Activated carbon adsorber filter element | P33KA00ESA |
| L-Bracket (fits to body) | P33KA00ML |
| T-Bracket (fits to body connector) | P32KA00MB |
| T-Bracket with body connector | P32KA00MT |
| Body connector | P32KA00CB |
| Differential pressure indicator (replacement) | P32KA00RQ |



Global Air Preparation System

Mini Regulator - P31

Symbols

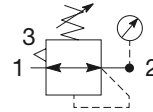

Self relieving regulator with gauge

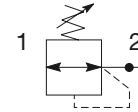

Non relieving regulator

- Integral 1/4" ports (NPT, BSPP & BSPT)
- Robust but lightweight aluminum construction
- Secondary pressure ranges 0-2 bar (0-30 psig), 0-4 bar, (0-60 psig), 0-8 bar (0-125 psig)
- Secondary aspiration plus balanced poppet provides quick response and accurate pressure regulation.
- Relieving & Non-relieving types
- Non-rising knob

Options:

| | | | | | | | | | | | | | | | | | | | | | | | | | | | | | | | | | | | | | | | | |
|------------------------------|---------------|------------------------------------------------------------------------------------------------------------------------------------------------------------------------------------------------------------------------------------------------------------------------------------------------------------------------------------|------|------------------|----------|-------------------------|----------|---------------------------------------------------------------------------------------------------------------------------|----------|---------------------------------------------------------------------------------------------------------------------------------------------------|-----|----------|--|--------------------------------------------------------------------------------------------------------------------------------------------------------------------------------------------------------------------------------------------------------------------------------------------------------------------------------------------------------------------------------------------------------------------------------------------------------------------------------------------------------------------------------------------------------------------------------------------------------------------------------------------------------------------------------------------------------------------------------------------------------------------------------------------------------------------------------|--|--------------------------|--|-------------|------------|----------------|---------------|---------------|--------------|----------------|--------------|-----------------------|--|-------------|------------|---------------|--------------|---------------|--------------|----------------|--------------|------------------------------------------------------------------------------------------------------------------------------------------------------------------------------------------------------------------------------------|-------------------------|--|--|----------|
| P 3 1 R | * | | | | | N | | P | | | | | | | | | | | | | | | | | | | | | | | | | | | | | | | | |
| Engr. level | | Thread type | | Port size | | Adjustment range | | Mounting | | | | | | | | | | | | | | | | | | | | | | | | | | | | | | | | |
| * Will be entered at factory | | <table border="1" style="width: 100%; border-collapse: collapse;"> <tr> <td>BSPP</td> <td style="text-align: center;">1</td> </tr> <tr> <td>BSPT</td> <td style="text-align: center;">2</td> </tr> <tr> <td>NPT</td> <td style="text-align: center;">9</td> </tr> </table> | BSPP | 1 | BSPT | 2 | NPT | 9 | | <table border="1" style="width: 100%; border-collapse: collapse;"> <tr> <td>1/4</td> <td style="text-align: center;">2</td> </tr> </table> | 1/4 | 2 | | <table border="1" style="width: 100%; border-collapse: collapse;"> <tr> <td colspan="2" style="text-align: center;">With square gauge</td> </tr> <tr> <td style="text-align: center;">psig</td> <td style="text-align: center;">bar</td> </tr> <tr> <td>30* = 1</td> <td>2* = V</td> </tr> <tr> <td>60 = 3</td> <td>4 = S</td> </tr> <tr> <td>125 = 5</td> <td>8 = T</td> </tr> <tr> <td colspan="2" style="text-align: center;">Without gauge†</td> </tr> <tr> <td style="text-align: center;">psig</td> <td style="text-align: center;">bar</td> </tr> <tr> <td>30 = Y</td> <td>2 = Y</td> </tr> <tr> <td>60 = L</td> <td>4 = L</td> </tr> <tr> <td>125 = N</td> <td>8 = N</td> </tr> </table> | | With square gauge | | psig | bar | 30* = 1 | 2* = V | 60 = 3 | 4 = S | 125 = 5 | 8 = T | Without gauge† | | psig | bar | 30 = Y | 2 = Y | 60 = L | 4 = L | 125 = N | 8 = N | <table border="1" style="width: 100%; border-collapse: collapse;"> <tr> <td colspan="2" style="text-align: center;">Plastic panel mount nut</td> </tr> <tr> <td></td> <td style="text-align: center;">P</td> </tr> </table> | Plastic panel mount nut | | | P |
| BSPP | 1 | | | | | | | | | | | | | | | | | | | | | | | | | | | | | | | | | | | | | | | |
| BSPT | 2 | | | | | | | | | | | | | | | | | | | | | | | | | | | | | | | | | | | | | | | |
| NPT | 9 | | | | | | | | | | | | | | | | | | | | | | | | | | | | | | | | | | | | | | | |
| 1/4 | 2 | | | | | | | | | | | | | | | | | | | | | | | | | | | | | | | | | | | | | | | |
| With square gauge | | | | | | | | | | | | | | | | | | | | | | | | | | | | | | | | | | | | | | | | |
| psig | bar | | | | | | | | | | | | | | | | | | | | | | | | | | | | | | | | | | | | | | | |
| 30* = 1 | 2* = V | | | | | | | | | | | | | | | | | | | | | | | | | | | | | | | | | | | | | | | |
| 60 = 3 | 4 = S | | | | | | | | | | | | | | | | | | | | | | | | | | | | | | | | | | | | | | | |
| 125 = 5 | 8 = T | | | | | | | | | | | | | | | | | | | | | | | | | | | | | | | | | | | | | | | |
| Without gauge† | | | | | | | | | | | | | | | | | | | | | | | | | | | | | | | | | | | | | | | | |
| psig | bar | | | | | | | | | | | | | | | | | | | | | | | | | | | | | | | | | | | | | | | |
| 30 = Y | 2 = Y | | | | | | | | | | | | | | | | | | | | | | | | | | | | | | | | | | | | | | | |
| 60 = L | 4 = L | | | | | | | | | | | | | | | | | | | | | | | | | | | | | | | | | | | | | | | |
| 125 = N | 8 = N | | | | | | | | | | | | | | | | | | | | | | | | | | | | | | | | | | | | | | | |
| Plastic panel mount nut | | | | | | | | | | | | | | | | | | | | | | | | | | | | | | | | | | | | | | | | |
| | P | | | | | | | | | | | | | | | | | | | | | | | | | | | | | | | | | | | | | | | |
| | | Relief | | | | | | | | | | | | | | | | | | | | | | | | | | | | | | | | | | | | | | |
| | | <table border="1" style="width: 100%; border-collapse: collapse;"> <tr> <td>Relieving</td> <td style="text-align: center;">B</td> </tr> <tr> <td>Non relieving</td> <td style="text-align: center;">N</td> </tr> <tr> <td>Reverse flow / relieving</td> <td style="text-align: center;">R</td> </tr> </table> | | Relieving | B | Non relieving | N | Reverse flow / relieving | R | | | | | | | | | | | | | | | | | | | | | | | | | | | | | | | |
| Relieving | B | | | | | | | | | | | | | | | | | | | | | | | | | | | | | | | | | | | | | | | |
| Non relieving | N | | | | | | | | | | | | | | | | | | | | | | | | | | | | | | | | | | | | | | | |
| Reverse flow / relieving | R | | | | | | | | | | | | | | | | | | | | | | | | | | | | | | | | | | | | | | | |
| | | | | | | | | <p>* Unit comes with 0-4 bar or 0-60 psig gauge respectively.</p> <p>† Order round gauges separately - see next page.</p> | | | | | | | | | | | | | | | | | | | | | | | | | | | | | | | | |

* Engineering Level will be entered at factory.

| Port size | Description | Order Code† | Flow‡ dm ³ /s (scfm) | Max. bar (psig) | Height mm (inches) | Width mm (inches) | Depth mm (inches) |
|-----------|----------------------------|--------------------|------------------------------------|--------------------|-----------------------|----------------------|----------------------|
| 1/4" | 8 bar (125 psig) relieving | P31R*92BNNP | 30 (64) | 20 (300) | 100.1 (3.94) | 40 (1.58) | 40 (1.58) |
| 1/4" | 8 bar (125 psig) + gauge | P31R*92BN5P | 30 (64) | 20 (300) | 100.1 (3.94) | 40 (1.58) | 64.3 (2.53) |

† Standard part numbers shown in bold. For other models refer to Options chart above.

‡ Flow with 10 bar (145 psig) inlet pressure, 6.3 bar (91.3 psig) set pressure and 1 bar (14.5 psig) pressure drop.

Global Air Preparation System

Specifications

| | | |
|--------------------------|---------------------------------|---------------------------------|
| Flow Capacity* | 1/4 | 30 dm ³ /s (64 scfm) |
| Operating Temperature† | -20°C to 65.5°C (-4°F to 150°F) | |
| Max. Supply Pressure | 20 bar (300 psig) | |
| Adjusting Range Pressure | 0-2 bar (30 psig) | |
| | 0-4 bar (60 psig) | |
| | 0-8 bar (125 psig) | |
| Port Size | BSPP / BSPT / NPT | 1/4 |
| Gauge Port (2 ea.)** | BSPP / BSPT / NPT | 1/8 |
| Weight | 0.17 kg (0.37 lbs) | |

* Inlet pressure 10 bar (145 psig). Secondary pressure 6.3 bar (91.3 psig).

** Non-gauge option only.

† Units with square gauges: -15°C to 65.5°C (5°F to 150°F)

Materials of Construction

| | |
|--------------------|------------------------|
| Body | Aluminum |
| Adjustment Knob | Acetal |
| Body Cap | ABS |
| Bonnet | PBT |
| Diaphragm Assembly | Brass / Nitrile |
| Bottom Plug | 33% Glass-Filled Nylon |
| Valve Assembly | Brass / Nitrile |
| Springs | Steel |
| Seals | Nitrile |
| Panel Nut | Acetal |

Dimensions mm (inches)

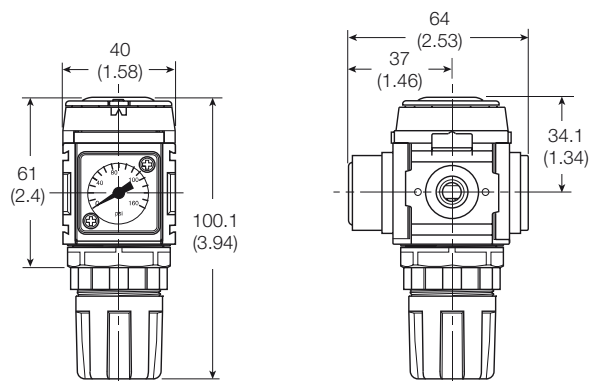

NOTE: 31.7 mm (1.25 in.) hole required for panel nut mounting.

WARNING

**Product rupture can cause serious injury.
Do not connect regulator to bottled gas.
Do not exceed Maximum primary pressure rating.**

CAUTION:

REGULATOR PRESSURE ADJUSTMENT – The working range of knob adjustment is designed to permit outlet pressures within their full range. Pressure adjustment beyond this range is also possible because the knob is not a limiting device. This is a common characteristic of most industrial regulators, and limiting devices may be obtained only by special design. For best performance, regulated pressure should always be set by increasing the pressure up to the desired setting.

Flow Charts

1/4 Regulator

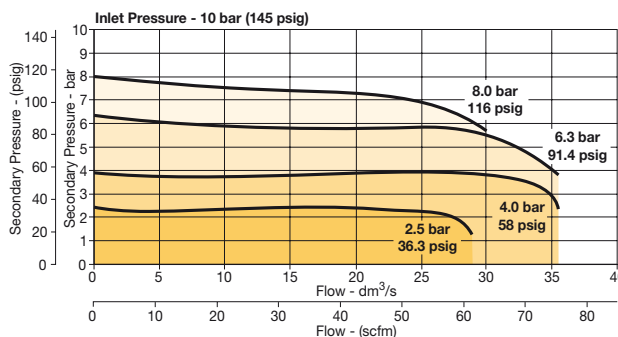

Repair and Service Kits

| | |
|------------------------------------------|------------------|
| Regulator repair kit - Relieving | P31KA00RB |
| Regulator repair kit - Non-relieving | P31KA00RC |
| Panel mount nut - Aluminum | P31KA00MM |
| Panel mount nut - Plastic | P31KA00MP |
| Angle Bracket (uses panel mount threads) | P31KA00MR |
| C-Bracket (fits to body) | P31KA00MW |
| T-Bracket with body connector | P31KA00MT |
| Body connector | P31KA00CB |

Gauges

Square flush mount gauge

| | |
|------------|--------------------|
| 0-4 bar | K4511SCR04B |
| 0-10 bar | K4511SCR11B |
| 0-60 psig | K4511SCR060 |
| 0-150 psig | K4511SCR150 |

1.00" Round 1/8" center back mount

| | |
|-----------------------|--------------------|
| 0-60 psig / 0-4 bar | K4510N18060 |
| 0-160 psig / 0-11 bar | K4510N18160 |

40mm Round 1/8" center back mount

(Not for use with Common Port Regulators)

| | |
|-----------------------|--------------------|
| 0-30 psig / 0-2 bar | K4515N18030 |
| 0-60 psig / 0-4 bar | K4515N18060 |
| 0-160 psig / 0-11 bar | K4515N18160 |

For best performance, regulated pressure should always be set by increasing the pressure up to the desired setting.

Global Air Preparation System

Mini Common - P1 Regulator - P31

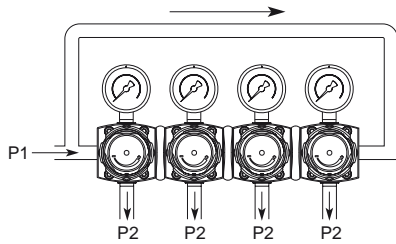
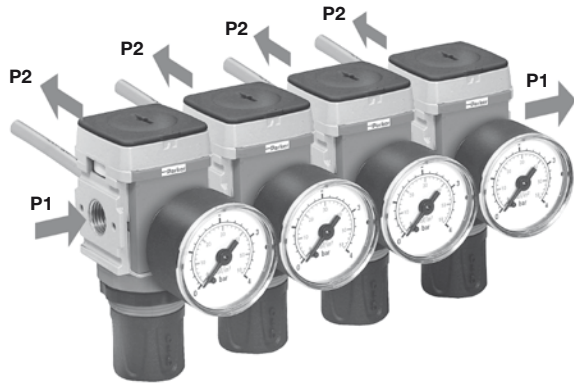

Symbols

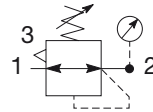

Self relieving regulator with gauge

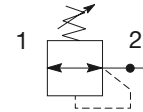

Non relieving regulator

- Manifold style regulator with line pressure on both sides.
- Pressure output is at front or rear.
- Integral 1/4" ports (NPT, BSPP & BSPT)
- Robust construction
- Secondary pressure ranges 0-2 bar (0-30 psig), 0-4 bar, (0-60 psig), 0-8 bar (0-125 psig)
- Secondary aspiration plus balanced poppet provides quick response and accurate pressure regulation
- Relieving & Non-relieving types
- Non-rising knob

Options:

| | | | | | | | | | |
|------------------------------|---|---------------------------|--|------------------|--|--------------------------------|--|-----------------------------------------------------------|---------------------------|
| P 3 1 H | * | | | | | N | | | P |
| Engr. level | | Thread type | | Port size | | Relief | | Adjustment range | Mounting |
| * Will be entered at factory | | BSPP 1 BSPT 2 NPT 9 | | 1/4 2 | | Relieving B Non relieving N | | Without gauge | Plastic panel mount nut P |
| | | | | | | | | 2 bar; 30 psig Y 4 bar; 60 psig L 8 bar; 125 psig N | |

Order gauges separately - see next page.

* Engineering Level will be entered at factory.

| Port size | Description | Order Code† | Flow‡ dm ³ /s (scfm) | Max. bar (psig) | Height mm (inches) | Width mm (inches) | Depth mm (inches) |
|-----------|----------------------------|--------------------|------------------------------------|--------------------|-----------------------|----------------------|----------------------|
| 1/4" | 8 bar (125 psig) Relieving | P31H*92BNNP | 18 (38) | 20 (300) | 100.1 (3.94) | 40 (1.58) | 40 (1.58) |

† Standard part numbers shown in bold. For other models refer to Options chart above.

‡ Flow with 10 bar (145 psig) inlet pressure, 6.3 bar (91.3) set pressure and 1 bar (14.5 psig) pressure drop.

Global Air Preparation System

Specifications

| | | |
|-------------------------------|---------------------------------|---------------------------------|
| Flow Capacity* | 1/4 | 18 dm ³ /s (38 scfm) |
| Operating Temperature | -20°C to 65.5°C (-4°F to 150°F) | |
| Max. Supply Pressure | 20 bar (300 psig) | |
| Adjusting Range Pressure | 0-2 bar (30 psig) | |
| | 0-4 bar (60 psig) | |
| | 0-8 bar (125 psig) | |
| P1 Port Size (Inlet / Outlet) | BSPP / BSPT / NPT | 1/4 |
| P2 Regulated Ports (2 ea.) | BSPP / BSPT / NPT | 1/8 |
| Weight | 0.30 kg (0.66 lbs) | |

* Inlet pressure 10 bar (145 psig). Secondary pressure 6.3 bar (91.3 psig).

Materials of Construction

| | |
|--------------------|------------------------|
| Body | Zinc |
| Adjustment Knob | Acetal |
| Body Cap | ABS |
| Bonnet | 33% Glass-filled PBT |
| Diaphragm Assembly | Brass / Nitrile |
| Bottom Plug | 33% Glass-filled Nylon |
| Valve Assembly | Brass / Nitrile |

Dimensions mm (inches)

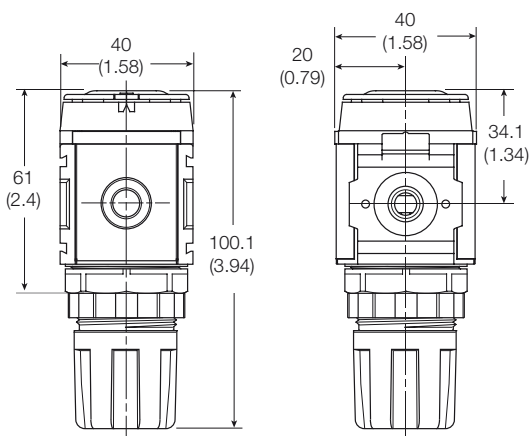

NOTE: 31.7 mm (1.25 in.) hole required for panel nut mounting.



WARNING

**Product rupture can cause serious injury.
Do not connect regulator to bottled gas.
Do not exceed Maximum primary pressure rating.**

CAUTION:

REGULATOR PRESSURE ADJUSTMENT – The working range of knob adjustment is designed to permit outlet pressures within their full range. Pressure adjustment beyond this range is also possible because the knob is not a limiting device. This is a common characteristic of most industrial regulators, and limiting devices may be obtained only by special design. For best performance, regulated pressure should always be set by increasing the pressure up to the desired setting.

Flow Charts

1/4 Common Regulator

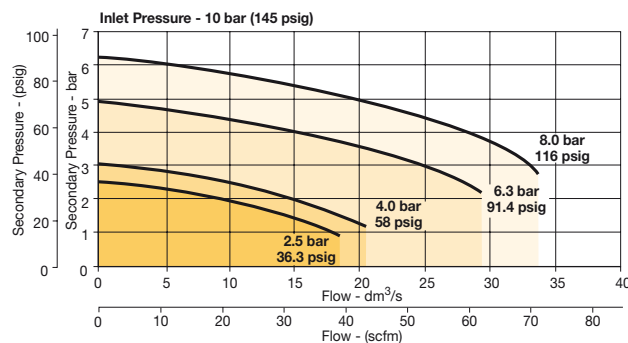

Repair and Service Kits

| | |
|------------------------------------------|------------------|
| Regulator repair kit - Relieving | P31KA00RB |
| Regulator repair kit - Non-relieving | P31KA00RC |
| Panel mount nut - Aluminum | P31KA00MM |
| Panel mount nut - Plastic | P31KA00MP |
| Angle Bracket (uses panel mount threads) | P31KA00MR |
| T-Bracket with body connector | P31KA00MT |
| Body connector | P31KA00CB |

Gauges

1.00" Round 1/8" center back mount

| | |
|-----------------------|--------------------|
| 0-60 psig / 0-4 bar | K4510N18060 |
| 0-160 psig / 0-11 bar | K4510N18160 |

For best performance, regulated pressure should always be set by increasing the pressure up to the desired setting.

Global Air Preparation System

Compact Regulator – P32

Symbols

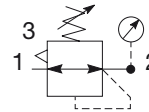

Self relieving regulator with gauge

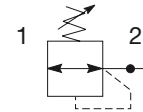

Non relieving regulator

- Integral 1/4", 3/8" or 1/2" ports (NPT, BSPP & BSPT)
- Robust but lightweight aluminum construction
- Secondary pressure ranges 0-2 bar (0-30 psig), 0-4 bar, (0-60 psig), 0-8 bar (0-125 psig), 0-17 bar (0-250 psig)
- Secondary aspiration plus balanced poppet provides quick response and accurate pressure regulation
- Relieving & Non-relieving types
- Non-rising knob

Options:

| | | | | | | | |
|------------------------------|---|--------------------|------------------|-----------------------------------|------------------------------------|--|----------------------------------|
| P 3 2 R | * | | | | N | | P |
| Engr. level | | Thread type | Port size | | Adjustment range | | Mounting |
| * Will be entered at factory | | BSPP 1 | 1/4 2 | | With round gauge | | Plastic panel mount nut P |
| | | BSPT 2 | 3/8 3 | | 2 bar; 30 psig; 0.2 MPa Z | | |
| | | NPT 9 | 1/2 4 | | 4 bar; 60 psig; 0.4 MPa M | | |
| | | | | Relief | 8 bar; 125 psig; 0.8 MPa G | | |
| | | | | Relieving B | 17 bar; 250 psig; 1.7 MPa J | | |
| | | | | Non relieving N | Without gauge | | |
| | | | | Reverse flow / relieving R | 2 bar; 30 psig; 0.2 MPa Y | | |
| | | | | | 4 bar; 60 psig; 0.4 MPa L | | |
| | | | | | 8 bar; 125 psig; 0.8 MPa N | | |
| | | | | | 17 bar; 250 psig; 1.7 MPa H | | |

* Engineering Level will be entered at factory.

| Port size | Description | Order Code† | Flow‡ dm ³ /s (scfm) | Max. bar (psig) | Height mm (inches) | Width mm (inches) | Depth mm (inches) |
|-----------|------------------------------------|--------------------|------------------------------------|--------------------|-----------------------|----------------------|----------------------|
| 1/4" | 8 bar (125 psig) Relieving | P32R*92BNNP | 41 (81) | 20 (300) | 136 (5.4) | 60 (2.36) | 60 (2.36) |
| 1/4" | 8 bar (125 psig) Relieving + Gauge | P32R*92BNGP | 41 (81) | 20 (300) | 136 (5.4) | 60 (2.36) | 60 (2.36) |
| 3/8" | 8 bar (125 psig) Relieving | P32R*93BNNP | 65 (138) | 20 (300) | 136 (5.4) | 60 (2.36) | 60 (2.36) |
| 3/8" | 8 bar (125 psig) Relieving + Gauge | P32R*93BNGP | 65 (138) | 20 (300) | 136 (5.4) | 60 (2.36) | 60 (2.36) |
| 1/2" | 8 bar (125 psig) Relieving | P32R*94BNNP | 67 (142) | 20 (300) | 136 (5.4) | 60 (2.36) | 60 (2.36) |
| 1/2" | 8 bar (125 psig) Relieving + Gauge | P32R*94BNGP | 67 (142) | 20 (300) | 136 (5.4) | 60 (2.36) | 60 (2.36) |

† Standard part numbers shown in bold. For other models refer to Options chart above.

‡ Flow with 10 bar (145 psig) inlet pressure, 6.3 bar (91.3 psig) set pressure and 1 bar (14.5 psig) pressure drop.



Global Air Preparation System

Specifications

| | | |
|--------------------------|-------------------------------------------------------------------------------------|----------------------------------|
| Flow Capacity* | 1/4 | 41 dm ³ /s (81 scfm) |
| | 3/8 | 65 dm ³ /s (138 scfm) |
| | 1/2 | 67 dm ³ /s (142 scfm) |
| Operating Temperature | -25°C to 65.5°C (-13°F to 150°F) | |
| Max. Supply Pressure | 20 bar (300 psig) | |
| Adjusting Range Pressure | 0-2 bar (30 psig) 0-4 bar (60 psig) 0-8 bar (125 psig) 0-17 bar (250 psig) | |
| Port Size | BSPP / BSPT / NPT | 1/4, 3/8, 1/2 |
| Gauge Port (2 ea.) | BSPP / BSPT / NPT | 1/4 |
| Weight | 0.41 kg (0.90 lbs) | |

* Inlet pressure 10 bar (145 psig). Secondary pressure 6.3 bar (91.3 psig).

Materials of Construction

| | | |
|--------------------|------------------------|------------|
| Body | Aluminum | |
| Adjustment Knob | Acetal | |
| Body Cap | ABS | |
| Bonnet | 33% Glass-filled nylon | |
| Diaphragm Assembly | Nitrile / Zinc | |
| Bottom Plug | 33% Glass-filled Nylon | |
| Valve Assembly | Brass / Nitrile | |
| Springs | Main Regulating Valve | Steel S.S. |
| Seals | Nitrile | |
| Panel Nut | Acetal | |

Dimensions mm (inches)

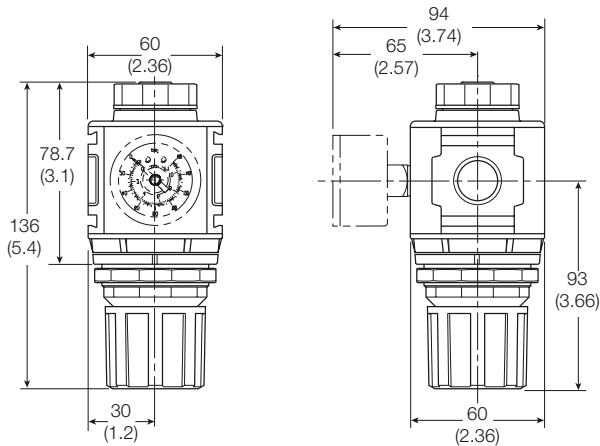

NOTE: 51 mm (2.00 in.) hole required for panel nut mounting.

WARNING

**Product rupture can cause serious injury.
Do not connect regulator to bottled gas.
Do not exceed Maximum primary pressure rating.**

CAUTION:

REGULATOR PRESSURE ADJUSTMENT – The working range of knob adjustment is designed to permit outlet pressures within their full range. Pressure adjustment beyond this range is also possible because the knob is not a limiting device. This is a common characteristic of most industrial regulators, and limiting devices may be obtained only by special design. For best performance, regulated pressure should always be set by increasing the pressure up to the desired setting.

Flow Charts

1/4 Regulator

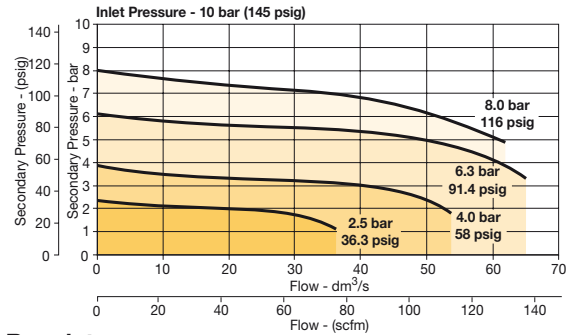

3/8 Regulator

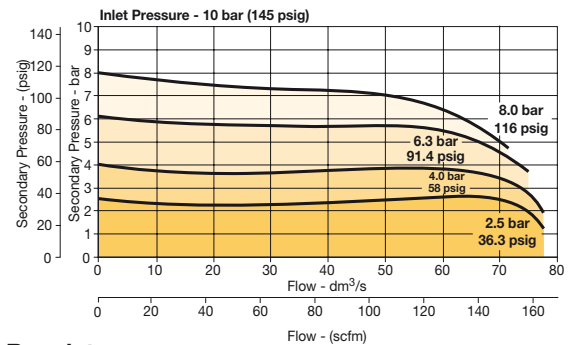

1/2 Regulator

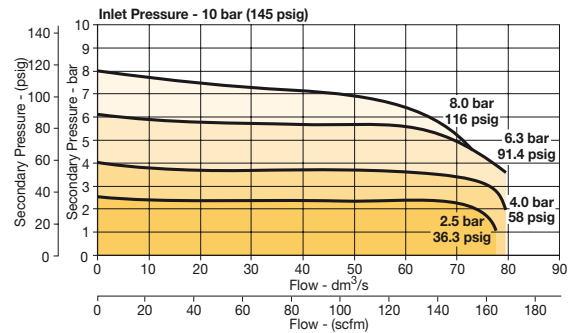

Repair and Service Kits

| | |
|------------------------------------------|------------------|
| Regulator repair kit - Relieving | P32KA00RB |
| Regulator repair kit - Non-relieving | P32KA00RC |
| Panel mount nut - Aluminum | P32KA00MM |
| Panel mount nut - Plastic | P32KA00MP |
| Angle Bracket (uses panel mount threads) | P32KA00MR |
| T-Bracket with body connector | P32KA00MT |
| T-Bracket | P32KA00MB |
| Body connector | P32KA00CB |

Gauges

| | |
|-----------------------------------------------|--------------------|
| 50mm (2") Round 1/4" center back mount | |
| 0-30 psig / 0-2 bar / 0-0.2 MPa | K4520N14030 |
| 0-60 psig / 0-4 bar / 0-0.4 MPa | K4520N14060 |
| 0-160 psig / 0-11 bar / 0-1.1 MPa | K4520N14160 |
| 0-300 psig / 0-20 bar / 0-2 MPa | K4520N14300 |

For best performance, regulated pressure should always be set by increasing the pressure up to the desired setting.



Global Air Preparation System

Compact Common P1 Regulator - P32

Symbols

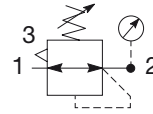
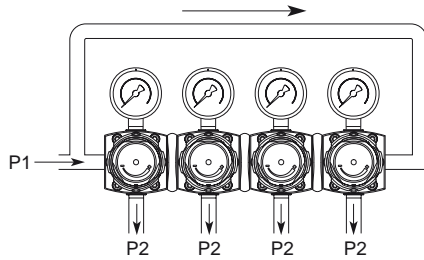

Self relieving regulator with gauge

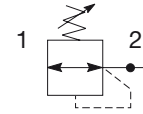

Non relieving regulator

- Manifold style regulator with line pressure on both sides.
- Pressure output is at front or rear.
- Integral 1/4", 3/8" or 1/2" ports (NPT, BSPP & BSPT)
- Robust construction
- Secondary pressure ranges 0-2 bar (0-30 psig), 0-4 bar, (0-60 psig), 0-8 bar (0-125 psig), 0-17 bar (0-250 psig)
- Secondary aspiration plus balanced poppet provides quick response and accurate pressure regulation
- Relieving & Non-relieving types
- Non-rising knob

Options:

| | | | | | | | |
|------------------------------|---|--------------------|------------------|------------------------|------------------------------------|----------------------------------|----------|
| P 3 2 H | * | | | | N | | P |
| Engr. level | | Thread type | Port size | | | Mounting | |
| * Will be entered at factory | | BSPP 1 | 1/4 2 | | | Plastic panel mount nut P | |
| | | BSPT 2 | 3/8 3 | | | | |
| | | NPT 9 | 1/2 4 | | | | |
| | | | | Relief | | | |
| | | | | Relieving B | | | |
| | | | | Non relieving N | | | |
| | | | | | Adjustment range | | |
| | | | | | Without gauge | | |
| | | | | | 2 bar; 30 psig; 0.2 MPa Y | | |
| | | | | | 4 bar; 60 psig; 0.4 MPa L | | |
| | | | | | 8 bar; 125 psig; 0.8 MPa N | | |
| | | | | | 17 bar; 250 psig; 1.7 MPa H | | |

Order gauges separately- see next page.

* Engineering Level will be entered at factory.

| Port size | Description | Order Code† | Flow‡ dm³/s (scfm) | Max. bar (psig) | Height mm (inches) | Width mm (inches) | Depth mm (inches) |
|-----------|----------------------------|--------------------|-----------------------|--------------------|-----------------------|----------------------|----------------------|
| 1/4" | 8 bar (125 psig) Relieving | P32H*92BNNP | 28 (59) | 20 (300) | 136 (5.4) | 60 (2.36) | 60 (2.36) |
| 3/8" | 8 bar (125 psig) Relieving | P32H*93BNNP | 28 (59) | 20 (300) | 136 (5.4) | 60 (2.36) | 60 (2.36) |
| 1/2" | 8 bar (125 psig) Relieving | P32H*94BNNP | 28 (59) | 20 (300) | 136 (5.4) | 60 (2.36) | 60 (2.36) |

† Standard part numbers shown in bold. For other models refer to Options chart above.

‡ Flow with 10 bar (145 psig) inlet pressure, 6.3 bar (91.3) psig set pressure and 1 bar (14.5 psig) pressure drop.

Global Air Preparation System

Specifications

| | | |
|--------------------------|-------------------------------------------------------------------------------------|---------------------------------|
| Flow Capacity* | 1/4 | 28 dm ³ /s (59 scfm) |
| | 3/8 | 28 dm ³ /s (59 scfm) |
| | 1/2 | 28 dm ³ /s (59 scfm) |
| Operating Temperature | -25°C to 65.5°C (-13°F to 150°F) | |
| Max. Supply Pressure | 20 bar (300 psig) | |
| Adjusting Range Pressure | 0-2 bar (30 psig) 0-4 bar (60 psig) 0-8 bar (125 psig) 0-17 bar (250 psig) | |
| Port Size | BSPP / BSPT / NPT | 1/4, 3/8, 1/2 |
| Gauge Port (2 ea.) | BSPP / BSPT / NPT | 1/4 |
| Weight | 0.50 kg (1.10 lbs) | |

* Inlet pressure 10 bar (145 psig). Secondary pressure 6.3 bar (91.3 psig).

Materials of Construction

| | | |
|--------------------|------------------------|---------------|
| Body | Zinc | |
| Adjustment Knob | Acetal | |
| Body Cap | ABS | |
| Bonnet | 33% Glass-filled nylon | |
| Diaphragm Assembly | Nitrile / Zinc | |
| Bottom Plug | 33% Glass-filled Nylon | |
| Valve Assembly | Brass / Nitrile | |
| Springs | Main Regulating Valve | Steel S.S. |
| Seals | Nitrile | |
| Panel Nut | Acetal | |

Dimensions mm (inches)

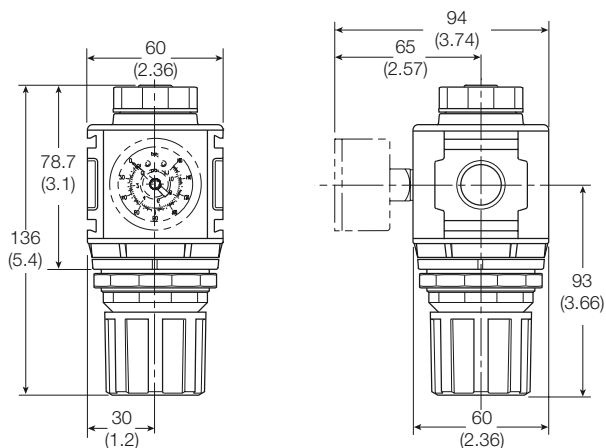

NOTE: 51 mm (2.00 in.) hole required for panel nut mounting.

WARNING

**Product rupture can cause serious injury.
Do not connect regulator to bottled gas.
Do not exceed Maximum primary pressure rating.**

CAUTION:

REGULATOR PRESSURE ADJUSTMENT – The working range of knob adjustment is designed to permit outlet pressures within their full range. Pressure adjustment beyond this range is also possible because the knob is not a limiting device. This is a common characteristic of most industrial regulators, and limiting devices may be obtained only by special design. For best performance, regulated pressure should always be set by increasing the pressure up to the desired setting.

Flow Charts

P32 Common Port Regulator

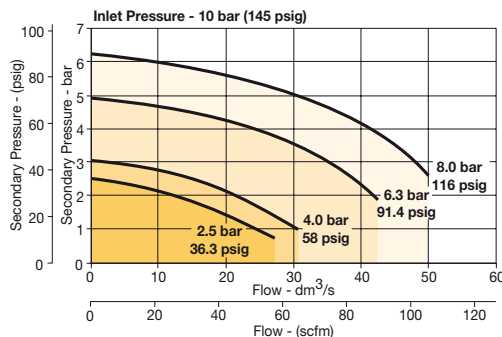

Repair and Service Kits

| | |
|------------------------------------------|------------------|
| Regulator repair kit - Relieving | P32KA00RB |
| Regulator repair kit - Non-relieving | P32KA00RC |
| Panel mount nut - Aluminum | P32KA00MM |
| Panel mount nut - Plastic | P32KA00MP |
| Angle Bracket (uses panel mount threads) | P32KA00MR |
| T-Bracket with body connector | P32KA00MT |
| T-Bracket | P32KA00MB |
| Body connector | P32KA00CB |

Gauges

50mm (2") Round 1/4" center back mount

| | |
|-----------------------------------|--------------------|
| 0-30 psig / 0-2 bar / 0-0.2 MPa | K4520N14030 |
| 0-60 psig / 0-4 bar / 0-0.4 MPa | K4520N14060 |
| 0-160 psig / 0-11 bar / 0-1.1 MPa | K4520N14160 |
| 0-300 psig / 0-20 bar / 0-2 MPa | K4520N14300 |

For best performance, regulated pressure should always be set by increasing the pressure up to the desired setting.

Global Air Preparation System

Standard Regulator - P33

Symbols

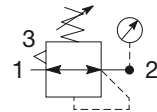

Self relieving regulator with gauge

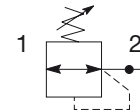

Non relieving regulator

- Integral 1/2" or 3/4" ports (NPT, BSPP & BSPT)
- Robust but lightweight aluminum construction
- Secondary pressure ranges 0-2 bar (0-30 psig), 0-4 bar, (0-60 psig), 0-8 bar (0-125 psig), 0-17 bar (0-250 psig)
- Secondary aspiration plus balanced poppet provides quick response and accurate pressure regulation
- Relieving & Non-relieving types
- Non-rising knob

Options:

| | | | | | | | | |
|----------------------------------------------------|---|----------------------------------------------------------------------------------------------------|--------------------------------------------------|--|----------|----------------------------------------------------------------------------------------------------------------------------------------------------------------------------------------------------------------------------------------------------------------------------------------------------------------------------------------------------------------------------------|-----------------------------------------------------|--|
| P 3 3 R | * | | | | N | | P | |
| Engr. level * Will be entered at factory | | Thread type BSPP 1 BSPT 2 NPT 9 | Port size 1/2 4 3/4 6 | | | Adjustment range With round gauge 2 bar; 30 psig; 0.2 MPa Z 4 bar; 60 psig; 0.4 MPa M 8 bar; 125 psig; 0.8 MPa G 17 bar; 250 psig; 1.7 MPa J Without gauge 2 bar; 30 psig; 0.2 MPa Y 4 bar; 60 psig; 0.4 MPa L 8 bar; 125 psig; 0.8 MPa N 17 bar; 250 psig; 1.7 MPa H | Mounting Plastic panel mount nut P | |
| | | Relief Relieving B Non relieving N Reverse flow / relieving R | | | | | | |

* Engineering Level will be entered at factory.

| Port size | Description | Order Code† | Flow‡ dm³/s (scfm) | Max. bar (psig) | Height mm (inches) | Width mm (inches) | Depth mm (inches) |
|-----------|------------------------------------|--------------------|-----------------------|--------------------|-----------------------|----------------------|----------------------|
| 1/2" | 8 bar (125 psig) Relieving | P33R*94BNNP | 100 (212) | 20 (300) | 149 (5.9) | 73 (2.9) | 73 (2.9) |
| 1/2" | 8 bar (125 psig) Relieving + Gauge | P33R*94BNGP | 100 (212) | 20 (300) | 149 (5.9) | 73 (2.9) | 73 (2.9) |
| 3/4" | 8 bar (125 psig) Relieving | P33R*96BNNP | 100 (212) | 20 (300) | 149 (5.9) | 73 (2.9) | 73 (2.9) |
| 3/4" | 8 bar (125 psig) Relieving + Gauge | P33R*96BNGP | 100 (212) | 20 (300) | 149 (5.9) | 73 (2.9) | 73 (2.9) |

† Standard part numbers shown in bold. For other models refer to Options chart above.

‡ Flow with 10 bar (145 psig) inlet pressure, 6.3 bar (91.3 psig) set pressure and 1 bar (14.5 psig) pressure drop.

Global Air Preparation System

Specifications

| | | |
|--------------------------|----------------------------------|-----------------------------------|
| Flow Capacity* | 1/2 | 100 dm ³ /s (212 scfm) |
| | 3/4 | 100 dm ³ /s (212 scfm) |
| Operating Temperature | -25°C to 65.5°C (-13°F to 150°F) | |
| Max. Supply Pressure | 20 bar (300 psig) | |
| Adjusting Range Pressure | 0-2 bar (30 psig) | |
| | 0-4 bar (60 psig) | |
| | 0-8 bar (125 psig) | |
| | 0-17 bar (250 psig) | |
| Port Size | BSP / BSPT / NPT | 1/2, 3/4 |
| Gauge Port (2 ea.) | BSP / BSPT / NPT | 1/4 |
| Weight | 0.62 kg (1.37 lbs) | |

* Inlet pressure 10 bar (145 psig). Secondary pressure 6.3 bar (91.3 psig).

Materials of Construction

| | | |
|--------------------|--------------------------|---------------|
| Body | Aluminum | |
| Adjustment Knob | Acetal | |
| Body Cap | ABS | |
| Bonnet | 33% Glass-filled Nylon | |
| Diaphragm Assembly | Nitrile / Zinc | |
| Valve Assembly | Brass / Nitrile / Acetal | |
| Springs | Main Regulating Valve | Steel S.S. |
| Seals | Nitrile | |
| Panel Nut | Acetal | |

Dimensions mm (inches)

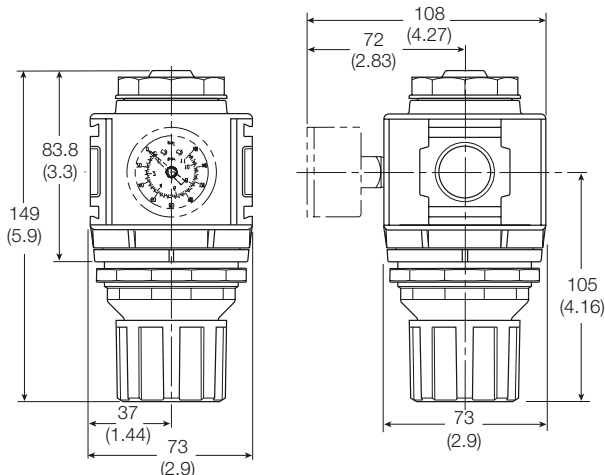

NOTE: 61 mm (2.40 in.) hole required for panel nut mounting.

WARNING

**Product rupture can cause serious injury.
Do not connect regulator to bottled gas.
Do not exceed Maximum primary pressure rating.**

CAUTION:

REGULATOR PRESSURE ADJUSTMENT – The working range of knob adjustment is designed to permit outlet pressures within their full range. Pressure adjustment beyond this range is also possible because the knob is not a limiting device. This is a common characteristic of most industrial regulators, and limiting devices may be obtained only by special design. For best performance, regulated pressure should always be set by increasing the pressure up to the desired setting.

Flow Charts

1/2 Regulator

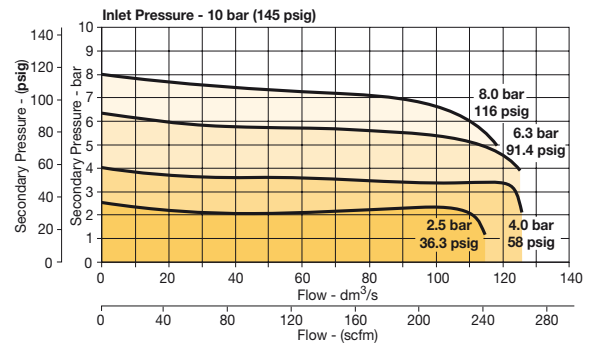

3/4 Regulator

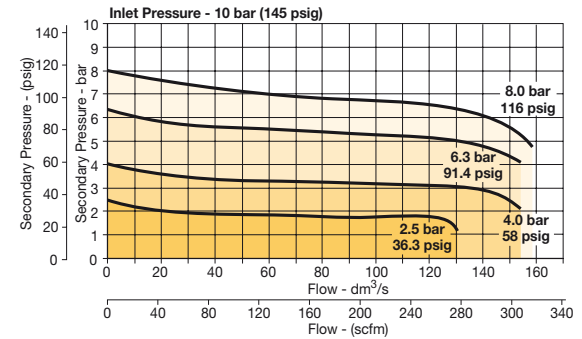

Repair and Service Kits

| | |
|------------------------------------------|------------------|
| Regulator repair kit - Relieving | P33KA00RB |
| Regulator repair kit - Non-relieving | P33KA00RC |
| Panel mount nut - Aluminum | P33KA00MM |
| Panel mount nut - Plastic | P33KA00MP |
| Angle Bracket (uses panel mount threads) | P33KA00MR |
| T-Bracket with body connector | P32KA00MT |
| T-Bracket | P32KA00MB |
| Body connector | P32KA00CB |

Gauges

50mm (2") Round 1/4" center back mount

| | |
|-----------------------------------|--------------------|
| 0-30 psig / 0-2 bar / 0-0.2 MPa | K4520N14030 |
| 0-60 psig / 0-4 bar / 0-0.4 MPa | K4520N14060 |
| 0-160 psig / 0-11 bar / 0-1.1 MPa | K4520N14160 |
| 0-300 psig / 0-20 bar / 0-2 MPa | K4520N14300 |

For best performance, regulated pressure should always be set by increasing the pressure up to the desired setting.

Global Air Preparation System

Mini Filter / Regulator - P31

Symbols

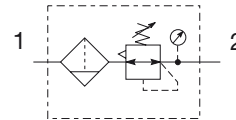

- Integral 1/4" ports (NPT, BSPP & BSPT)
 - High efficiency 5 micron element as standard
 - Excellent water removal efficiency
 - Robust but lightweight aluminum construction
 - Positive bayonet latch to ensure correct & safe fitting
- Secondary pressure ranges 0-2 bar (0-30 psig), 0-4 bar, (0-60 psig), 0-8 bar (0-125 psig)
- Secondary aspiration plus balanced poppet provides quick response and accurate pressure regulation

Options:

| | | | | | | | | | | | | | | | | |
|------------------------------|----------|-----------------------------------------------------------------|----------|---------------------------------|--|--------------------------------|--|-------------------------------------------------------------------------------------------------------------------------------------------------------------------------------------------------------------|--|---------------------------|--|----------|--|--|--|----------|
| P | 3 | 1 | E | * | | | | E | | | | N | | | | P |
| Engr. level | | Thread type | | Drain type | | Relief | | Adjustment range | | Mounting | | | | | | |
| * Will be entered at factory | | BSPP 1 BSPT 2 NPT 9 | | Pulse drain B Manual drain M | | Relieving B Non relieving N | | With square gauge psig bar 30* = 1 2* = V 60 = 3 4 = S 125 = 5 8 = T Without gauge psig bar 30 = Y 2 = Y 60 = L 4 = L 125 = N 8 = N | | Plastic panel mount nut P | | | | | | |
| | | Port size | | | | | | | | | | | | | | |
| | | 1/4 2 | | | | | | | | | | | | | | |
| | | Element | | | | | | | | | | | | | | |
| | | 5µ Element E | | | | | | | | | | | | | | |
| | | Bowl type | | | | | | | | | | | | | | |
| | | Poly bowl with bowl guard G Metal bowl without sight gauge M | | | | | | | | | | | | | | |

* Unit comes with 0-4 bar, 0-60 psig gauge respectively

* Engineering Level will be entered at factory.

| Port size | Description | Order Code† | Flow‡ dm³/s (scfm) | Max. bar (psig) | Height mm (inches) | Width mm (inches) | Depth mm (inches) |
|-----------|--------------------------------------------------------|-----------------------|-----------------------|-----------------|--------------------|-------------------|-------------------|
| 1/4" | 8 bar (125 psig) Relieving - Poly bowl - Manual drain | P31E*92EGMBN5P | 14 (30) | 10 (150) | 164.1 (6.46) | 40 (1.58) | 64 (2.53) |
| 1/4" | 8 bar (125 psig) Relieving - Poly bowl - Pulse drain | P31E*92EGBBN5P | 14 (30) | 10 (150) | 164.1 (6.46) | 40 (1.58) | 64 (2.53) |
| 1/4" | 8 bar (125 psig) Relieving - Metal bowl - Manual drain | P31E*92EMMBN5P | 14 (30) | 17 (250) | 164.1 (6.46) | 40 (1.58) | 64 (2.53) |
| 1/4" | 8 bar (125 psig) Relieving - Metal bowl - Pulse drain | P31E*92EMBBN5P | 14 (30) | 17 (250) | 164.1 (6.46) | 40 (1.58) | 64 (2.53) |

† Standard part numbers shown in bold. For other models refer to Options chart above.

‡ Flow with 10 bar (145 psig) inlet pressure, 6.3 bar (91.3) set pressure and 1 bar (14.5 psig) pressure drop.

Global Air Preparation System

Specifications

| | | |
|--------------------------|---------------------------------|-----------------------------------|
| Flow Capacity* | 1/4 | 14 dm ³ /s (30.0 scfm) |
| Operating Temperature† | Plastic Bowl | -10°C to 52°C (14°F to 125°F) |
| | Metal Bowl | -10°C to 65.5°C (14°F to 150°F) |
| Max. Supply Pressure | Plastic Bowl | 10 bar (150 psig) |
| | Metal Bowl | 17 bar (250 psig) |
| Standard Filtration | 5 Micron | |
| Useful Retention | 12 cm ³ (0.4 US oz.) | |
| Adjusting Range Pressure | 0-2 bar (30 psig) | |
| | 0-4 bar (60 psig) | |
| | 0-8 bar (125 psig) | |
| Port Size | BSPP / BSPT / NPT | 1/4 |
| Gauge Port (2 ea.)** | BSPP / BSPT / NPT | 1/8 |
| Weight | 0.19 kg (0.42 lbs) | |

* Inlet pressure 10 bar (145 psig). Secondary pressure 6.3 bar (91.3 psig).

** Non-gauge option only.

† Units with square gauges: -15°C to 65.5°C (5°F to 150°F)

Air quality:

Within ISO 8573-1: 1991 Class 3 (Particulates)

Within ISO 8573-1: 2001 Class 6 (Particulates)

Materials of Construction

| | | |
|--------------------|-----------------|---------------|
| Body | Aluminum | |
| Adjustment Knob | Acetal | |
| Body Cap | ABS | |
| Bonnet | PBT | |
| Bowl | Plastic Bowl | Polycarbonate |
| | Metal Bowl | Aluminum |
| Bowl Guard | Nylon | |
| Filter Element | Polyethylene | |
| Seals | Nitrile | |
| Springs | Steel | |
| Valve Assembly | Brass / Nitrile | |
| Diaphragm Assembly | Brass / Nitrile | |
| Panel Nut | Acetal | |

For best performance, regulated pressure should always be set by increasing the pressure up to the desired setting.

Dimensions mm (inches)

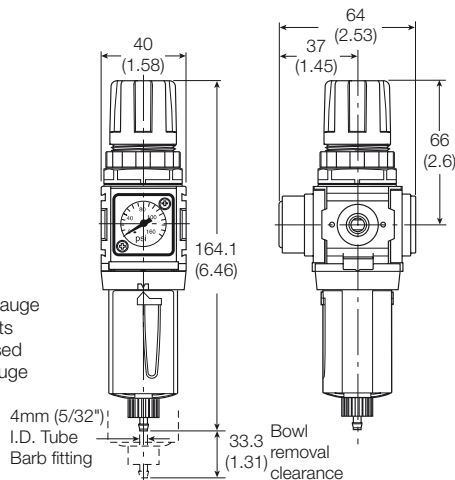

Note:
Flush-mounted gauge kits will not fit units originally purchased with threaded gauge ports.

Flow Charts

1/4 Filter/Regulator

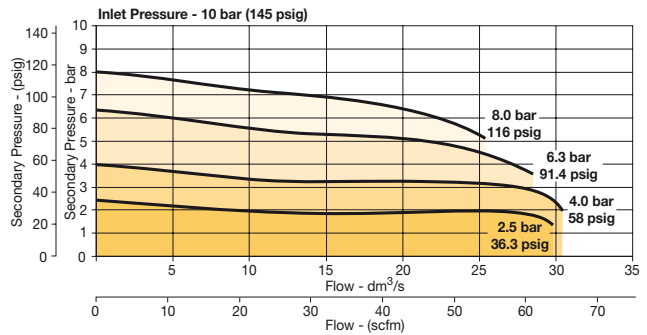

Repair and Service Kits

| | |
|-------------------------------------------|-------------------|
| Plastic bowl / Bowl guard manual drain | P31KA00BGM |
| Metal bowl / w/o sight gauge manual drain | P31KA00BMM |
| Plastic bowl / Bowl guard pulse drain | P31KA00BGB |
| Metal bowl / w/o sight gauge pulse drain | P31KA00BMB |
| 5µ particle filter element | P31KA00ESE |
| Regulator repair kit - Relieving | P31KA00RB |
| Regulator repair kit - Non-relieving | P31KA00RC |
| Panel mount nut - Aluminum | P31KA00MM |
| Panel mount nut - Plastic | P31KA00MP |
| Angle Bracket (uses panel mount threads) | P31KA00MR |
| C-Bracket (fits to body) | P31KA00MW |
| T-Bracket with body connector | P31KA00MT |
| Body connector | P31KA00CB |

Gauges

Square flush mount gauge

| | |
|------------|--------------------|
| 0-4 bar | K4511SCR04B |
| 0-10 bar | K4511SCR11B |
| 0-60 psig | K4511SCR060 |
| 0-150 psig | K4511SCR150 |

For best performance, regulated pressure should always be set by increasing the pressure up to the desired setting.

⚠ WARNING

**Product rupture can cause serious injury.
Do not connect regulator to bottled gas.
Do not exceed Maximum primary pressure rating.**

Global Air Preparation System

Compact Filter / Regulator - P32

Symbols

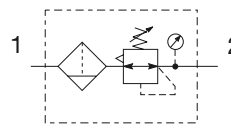

- Integral 1/4", 3/8" or 1/2" ports (NPT, BSPP & BSPT)
- High efficiency 5 micron element as standard
- Excellent water removal efficiency
- Robust but lightweight aluminum construction
- Positive bayonet latch to ensure correct & safe fitting
- Secondary pressure ranges 0-2 bar (0-30 psig), 0-4 bar (0-60 psig), 0-8 bar (0-125 psig), 0-17 bar (0-250 psig)
- Secondary aspiration plus balanced poppet provides quick response and accurate pressure regulation

Options:

| | | | | | | | | | | |
|------------------------------|----------|--------------------------------|----------|-------------------|----------|---------------------------|--|-----------|--|-------------------------|
| P 3 2 E | * | | | E | | | | N | | P |
| Thread type | | Port size | | Drain type | | Adjustment range | | | | Mounting |
| BSPP | 1 | 1/4 | 2 | Manual drain | M | With round gauge | | | | Plastic panel mount nut |
| BSPT | 2 | 3/8 | 3 | Auto drain | A | 2 bar; 30 psig; 0.2 MPa | | Z | | |
| NPT | 9 | 1/2 | 4 | | | 4 bar; 60 psig; 0.4 MPa | | M | | |
| Engr. level | | Element | | Relief | | 8 bar; 125 psig; 0.8 MPa | | G | | |
| * Will be entered at factory | | 5µ Element | | Relieving | | 17 bar; 250 psig; 1.7 MPa | | J* | | |
| | | Bowl type | | Non relieving | | Without gauge | | | | |
| | | Poly bowl with bowl guard | | N | | 2 bar; 30 psig; 0.2 MPa | | Y | | |
| | | Metal bowl without sight gauge | | | | 4 bar; 60 psig; 0.4 MPa | | L | | |
| | | Metal bowl with sight gauge | | | | 8 bar; 125 psig; 0.8 MPa | | N | | |
| | | | | | | 17 bar; 250 psig; 1.7 MPa | | H* | | |

* Not available with poly bowl with bowl guard.

* Engineering Level will be entered at factory.

| Port size | Description | Order Code† | Flow‡ dm³/s (scfm) | Max. bar (psig) | Height mm (inches) | Width mm (inches) | Depth mm (inches) |
|-----------|--------------------------------------------------------|-----------------------|-----------------------|-----------------|-----------------------|----------------------|----------------------|
| 1/4" | 8 bar (125 psig) Relieving - Poly bowl - Manual drain | P32E*92EGMBNGP | 42 (89) | 10 (150) | 254 (10.0) | 60 (2.36) | 60 (2.36) |
| 1/4" | 8 bar (125 psig) Relieving - Poly bowl - Auto drain | P32E*92EGABNGP | 42 (89) | 10 (150) | 248 (9.76) | 60 (2.36) | 60 (2.36) |
| 1/4" | 8 bar (125 psig) Relieving - Metal bowl - Manual drain | P32E*92ESMBNGP | 42 (89) | 17 (250) | 245 (9.66) | 60 (2.36) | 60 (2.36) |
| 1/4" | 8 bar (125 psig) Relieving - Metal bowl - Auto drain | P32E*92ESABNGP | 42 (89) | 17 (250) | 254 (10.0) | 60 (2.36) | 95 (3.74) |
| 3/8" | 8 bar (125 psig) Relieving - Poly bowl - Manual drain | P32E*93EGMBNGP | 58 (123) | 10 (150) | 254 (10.0) | 60 (2.36) | 60 (2.36) |
| 3/8" | 8 bar (125 psig) Relieving - Poly bowl - Auto drain | P32E*93EGABNGP | 58 (123) | 10 (150) | 248 (9.76) | 60 (2.36) | 60 (2.36) |
| 3/8" | 8 bar (125 psig) Relieving - Metal bowl - Manual drain | P32E*93ESMBNGP | 58 (123) | 17 (250) | 245 (9.66) | 60 (2.36) | 60 (2.36) |
| 3/8" | 8 bar (125 psig) Relieving - Metal bowl - Auto drain | P32E*93ESABNGP | 58 (123) | 17 (250) | 254 (10.0) | 60 (2.36) | 95 (3.74) |
| 1/2" | 8 bar (125 psig) Relieving - Poly bowl - Manual drain | P32E*94EGMBNGP | 64 (136) | 10 (150) | 245 (9.66) | 60 (2.36) | 95 (3.74) |
| 1/2" | 8 bar (125 psig) Relieving - Poly bowl - Auto drain | P32E*94EGABNGP | 64 (136) | 10 (150) | 248 (9.76) | 60 (2.36) | 95 (3.74) |
| 1/2" | 8 bar (125 psig) Relieving - Metal bowl - Manual drain | P32E*94ESMBNGP | 64 (136) | 17 (250) | 245 (9.66) | 60 (2.36) | 60 (2.36) |
| 1/2" | 8 bar (125 psig) Relieving - Metal bowl - Auto drain | P32E*94ESABNGP | 64 (136) | 17 (250) | 254 (10.0) | 60 (2.36) | 60 (2.36) |

† Standard part numbers shown in bold. For other models refer to Options chart above.

‡ Flow with 10 bar (145 psig) inlet pressure, 6.3 bar (91.3 psig) set pressure and 1 bar (14.5 psig) pressure drop.



Global Air Preparation System

Specifications

| | | |
|--------------------------|-------------------|-------------------------------------------------------------------------------------|
| Flow Capacity* | 1/4 | 42 dm ³ /s (89 scfm) |
| | 3/8 | 58 dm ³ /s (123 scfm) |
| | 1/2 | 64 dm ³ /s (136 scfm) |
| Operating Temperature | Plastic Bowl | -25°C to 52°C (-13°F to 125°F) |
| | Metal Bowl | -25°C to 65.5°C (-13°F to 150°F) |
| Max. Supply Pressure | Plastic Bowl | 10 bar (150 psig) |
| | Metal Bowl | 17 bar (250 psig) |
| Standard Filtration | | 5 Micron |
| Useful Retention† | | 51 cm ³ (1.7 US oz.) |
| Adjusting Range Pressure | | 0-2 bar (30 psig) 0-4 bar (60 psig) 0-8 bar (125 psig) 0-17 bar (250 psig) |
| Port Size | BSPB / BSPT / NPT | 1/4, 3/8, 1/2 |
| Gauge Port (2 ea.) | BSPB / BSPT / NPT | 1/4 |
| Weight | | 0.53 kg (1.17 lbs) |

* Inlet pressure 10 bar (145 psig). Secondary pressure 6.3 bar (91.3 psig).
 † Useful retention refers to volume below the quiet zone baffle.

Air quality:

Within ISO 8573-1: 1991 Class 3 (Particulates)
 Within ISO 8573-1: 2001 Class 6 (Particulates)

Materials of Construction

| | | |
|---------------------------|-------------------------|---------------|
| Body | Aluminum | |
| Adjustment Knob | Acetal | |
| Body Cap | ABS | |
| Element Retainer / Baffle | Acetal | |
| Bowl | Plastic Bowl | Polycarbonate |
| | Metal Bowl | Zinc |
| Bowl Guard | Nylon | |
| Filter Element | Sintered Polyethylene | |
| Seals | Nitrile | |
| Springs | Main Regulating / Valve | Steel / S.S. |
| Valve Assembly | Brass / Nitrile | |
| Diaphragm Assembly | Nitrile / Zinc | |
| Panel Nut | Acetal | |
| Sight Gauge | Metal Bowl | Polycarbonate |

Dimensions mm (inches)

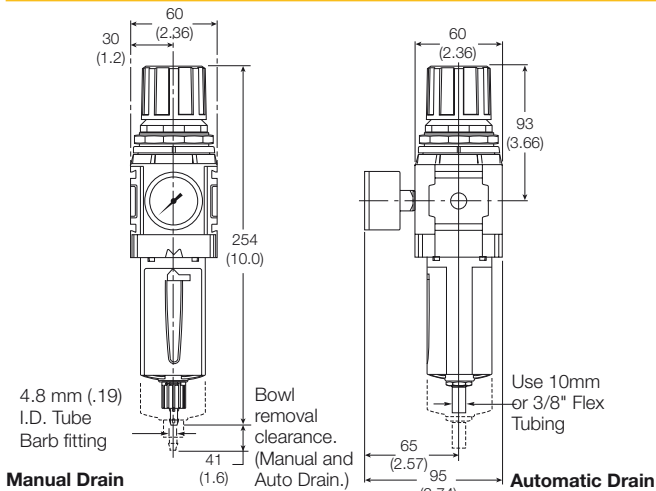

WARNING
 Product rupture can cause serious injury.
 Do not connect regulator to bottled gas.
 Do not exceed Maximum primary pressure rating.

Flow Charts

1/4 Filter/Regulator

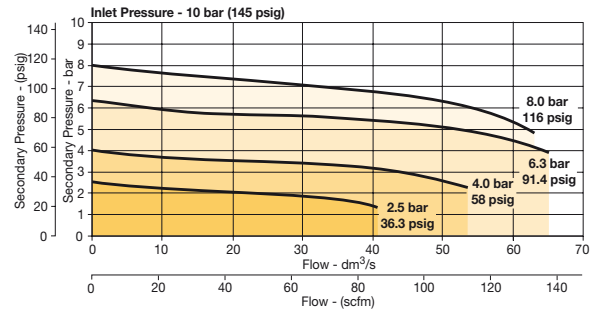

3/8 Filter/Regulator

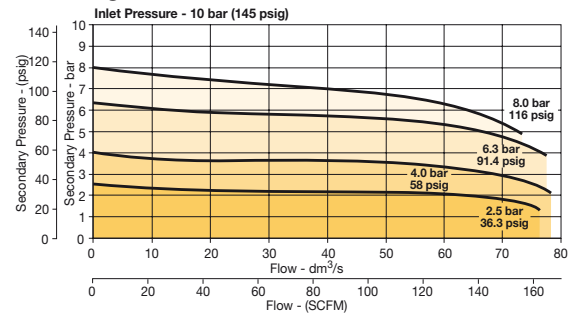

1/2 Filter/Regulator

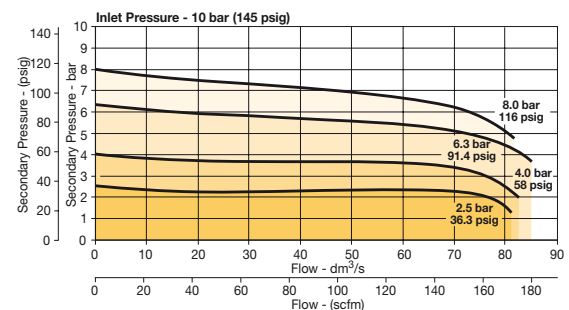

Repair and Service Kits

| | |
|---------------------------------------------|-------------------|
| Plastic bowl / Bowl guard manual drain | P32KA00BGM |
| Metal bowl / Sight gauge manual drain | P32KA00BSM |
| Auto drain | P32KA00DA |
| 5µ particle filter element | P32KA00ESE |
| Regulator repair kit - Relieving | P32KA00RB |
| Regulator repair kit - Non-relieving | P32KA00RC |
| Panel mount nut - Aluminum | P32KA00MM |
| Panel mount nut - Plastic | P32KA00MP |
| Angle Bracket (fits to panel mount threads) | P32KA00MR |
| T-Bracket (fits to body connector) | P32KA00MB |
| T-Bracket with body connector | P32KA00MT |
| Body connector | P32KA00CB |

Gauges

50mm (2") Round 1/4" center back mount

| | |
|-----------------------------------|--------------------|
| 0-30 psig / 0-2 bar / 0-0.2 MPa | K4520N14030 |
| 0-60 psig / 0-4 bar / 0-0.4 MPa | K4520N14060 |
| 0-160 psig / 0-11 bar / 0-1.1 MPa | K4520N14160 |
| 0-300 psig / 0-20 bar / 0-2 MPa | K4520N14300 |

For best performance, regulated pressure should always be set by increasing the pressure up to the desired setting.

Global Air Preparation System

Standard Filter / Regulator - P33

Symbols

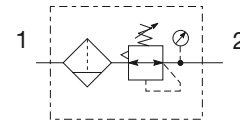

- Integral 1/2" or 3/4" ports (NPT, BSPP & BSPT)
- High efficiency 5 micron element as standard
- Excellent water removal efficiency
- Robust but lightweight aluminum construction
- Positive bayonet latch to ensure correct & safe fitting
- Secondary pressure ranges 0-2 bar (0-30 psig), 0-4 bar, (0-60 psig), 0-8 bar (0-125 psig), 0-17 bar (0-250 psig)
- Secondary aspiration plus balanced poppet provides quick response and accurate pressure regulation

Options:

| | | | | | | | | | | |
|------------------------------|----------|--------------------------------|----------|-------------------|----------|---------------------------|--|-------------------------|--|----------|
| P 3 3 E | * | | | E | | | | N | | P |
| Thread type | | Port size | | Drain type | | Adjustment range | | Mounting | | |
| BSPP | 1 | 1/2 | 4 | Manual drain | M | With round gauge | | Plastic panel mount nut | | |
| BSPT | 2 | 3/4 | 6 | Auto drain | A | 2 bar; 30 psig; 0.2 MPa | | Z | | |
| NPT | 9 | | | | | 4 bar; 60 psig; 0.4 MPa | | M | | |
| Engr. level | | Element | | Relief | | 8 bar; 125 psig; 0.8 MPa | | G | | |
| * Will be entered at factory | | 5µ Element | | Relieving | | 17 bar; 250 psig; 1.7 MPa | | J* | | |
| | | Bowl type | | Non relieving | | Without gauge | | N | | |
| | | Poly bowl with bowl guard | | B | | 2 bar; 30 psig; 0.2 MPa | | Y | | |
| | | Metal bowl without sight gauge | | N | | 4 bar; 60 psig; 0.4 MPa | | L | | |
| | | Metal bowl with sight gauge | | S | | 8 bar; 125 psig; 0.8 MPa | | N | | |
| | | | | | | 17 bar; 250 psig; 1.7 MPa | | H* | | |

* Not available with poly bowl with bowl guard.

* Engineering Level will be entered at factory.

| Port size | Description | Order Code† | Flow‡ dm ³ /s (scfm) | Max. bar (psig) | Height mm (inches) | Width mm (inches) | Depth mm (inches) |
|-----------|--------------------------------------------------------|-----------------------|------------------------------------|--------------------|-----------------------|----------------------|----------------------|
| 1/2" | 8 bar (125 psig) Relieving - Poly bowl - Manual drain | P33E*94EGMBNGP | 90 (191) | 10 (150) | 291 (11.44) | 73 (2.9) | 73 (2.9) |
| 1/2" | 8 bar (125 psig) Relieving - Poly bowl - Auto drain | P33E*94EGABNGP | 90 (191) | 10 (150) | 285 (11.22) | 73 (2.9) | 73 (2.9) |
| 1/2" | 8 bar (125 psig) Relieving - Metal bowl - Manual drain | P33E*94ESMBNGP | 90 (191) | 17 (250) | 282 (11.0) | 73 (2.9) | 73 (2.9) |
| 1/2" | 8 bar (125 psig) Relieving - Metal bowl - Auto drain | P33E*94ESABNGP | 90 (191) | 17 (250) | 291 (11.44) | 73 (2.9) | 108 (4.27) |
| 3/4" | 8 bar (125 psig) Relieving - Poly bowl - Manual drain | P33E*96EGMBNGP | 98 (208) | 10 (150) | 282 (11.0) | 73 (2.9) | 108 (4.27) |
| 3/4" | 8 bar (125 psig) Relieving - Poly bowl - Auto drain | P33E*96EGABNGP | 98 (208) | 10 (150) | 285 (11.22) | 73 (2.9) | 108 (4.27) |
| 3/4" | 8 bar (125 psig) Relieving - Metal bowl - Manual drain | P33E*96ESMBNGP | 98 (208) | 17 (250) | 291 (11.44) | 73 (2.9) | 73 (2.9) |
| 3/4" | 8 bar (125 psig) Relieving - Metal bowl - Auto drain | P33E*96ESABNGP | 98 (208) | 17 (250) | 282 (11.0) | 73 (2.9) | 73 (2.9) |

† Standard part numbers shown in bold. For other models refer to Options chart above.

‡ Flow with 10 bar (145 psig) inlet pressure, 6.3 bar (91.3) set pressure and 1 bar (14.5 psig) pressure drop.



Global Air Preparation System

Specifications

| | | |
|--------------------------|---------------------------------|----------------------------------|
| Flow Capacity* | 1/2 | 90 dm ³ /s (191 scfm) |
| | 3/4 | 98 dm ³ /s (208 scfm) |
| Operating Temperature | Plastic Bowl | -25°C to 52°C (-13°F to 125°F) |
| | Metal Bowl | -25°C to 65.5°C (-13°F to 150°F) |
| Supply Pressure | Plastic Bowl | 10 bar (150 psig) |
| | Metal Bowl | 17 bar (250 psig) |
| Standard Filtration | 5 Micron | |
| Useful Retention† | 85 cm ³ (2.8 US oz.) | |
| Adjusting Range Pressure | 0-2 bar (30 psig) | |
| | 0-4 bar (60 psig) | |
| | 0-8 bar (125 psig) | |
| | 0-17 bar (250 psig) | |
| Port Size | BSP / BSPT / NPT | 1/2, 3/4 |
| Gauge Port (2 ea.) | BSP / BSPT / NPT | 1/4 |
| Weight | 0.85 kg (1.87 lbs) | |

* Inlet pressure 10 bar (145 psig). Secondary pressure 6.3 bar (91.3 psig).

† Useful retention refers to volume below the quiet zone baffle.

Air quality:

Within ISO 8573-1: 1991 Class 3 (Particulates)

Within ISO 8573-1: 2001 Class 6 (Particulates)

Materials of Construction

| | | |
|---------------------------|-------------------------|---------------|
| Body | Aluminum | |
| Adjustment Knob | Acetal | |
| Body Cap | ABS | |
| Element Retainer / Baffle | Acetal | |
| Bowls | Plastic Bowl | Polycarbonate |
| | Metal Bowl | Aluminum |
| Filter Element | Sintered Polyethylene | |
| Seals | Nitrile | |
| Springs | Main Regulating / Valve | Steel / S.S. |
| Valve Assembly | Brass / Nitrile | |
| Diaphragm Assembly | Nitrile / Zinc | |
| Panel Nut | Acetal | |
| Sight Gauge | Metal Bowl | Polycarbonate |

Dimensions mm (inches)

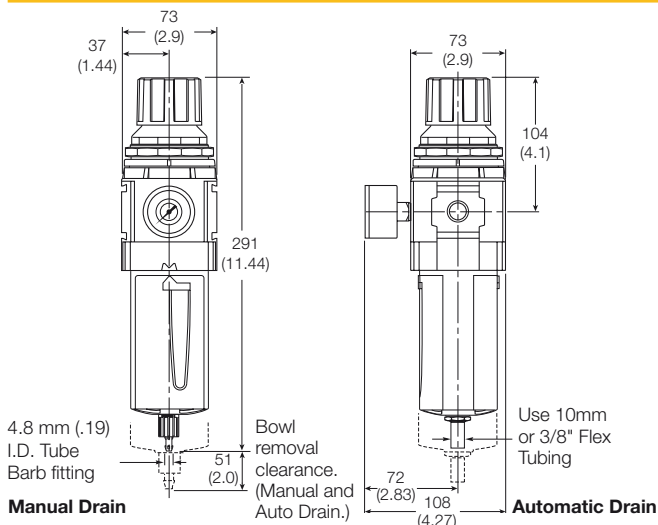

WARNING
 Product rupture can cause serious injury.
 Do not connect regulator to bottled gas.
 Do not exceed Maximum primary pressure rating.

Flow Charts

1/2 Filter/Regulator

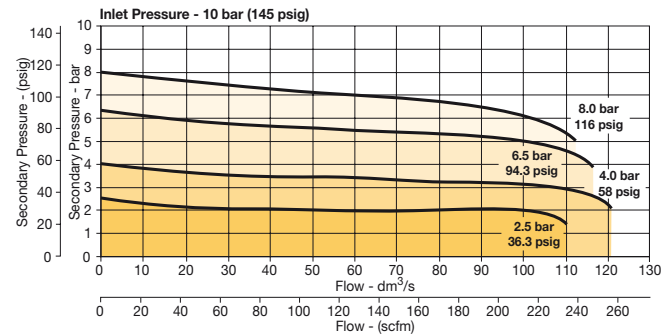

3/4 Filter/Regulator

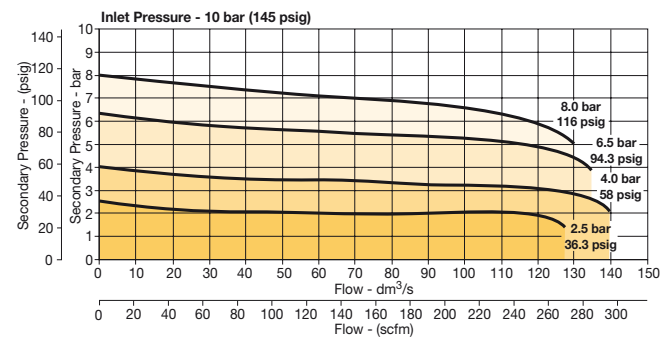

Repair and Service Kits

| | |
|---------------------------------------------|-------------------|
| Plastic bowl / Bowl guard manual drain | P33KA00BGM |
| Metal bowl / Sight gauge manual drain | P33KA00BSM |
| Auto drain | P32KA00DA |
| 5µ particle filter element | P33KA00ESE |
| Regulator repair kit - Relieving | P33KA00RB |
| Regulator repair kit - Non-relieving | P33KA00RC |
| Panel mount nut - Aluminum | P33KA00MM |
| Panel mount nut - Plastic | P33KA00MP |
| Angle Bracket (fits to panel mount threads) | P33KA00MR |
| T-Bracket (fits to body connector) | P32KA00MB |
| T-Bracket with body connector | P32KA00MT |
| Body connector | P32KA00CB |

Gauges

50mm (2") Round 1/4" center back mount

| | |
|-----------------------------------|--------------------|
| 0-30 psig / 0-2 bar / 0-0.2 MPa | K4520N14030 |
| 0-60 psig / 0-4 bar / 0-0.4 MPa | K4520N14060 |
| 0-160 psig / 0-11 bar / 0-1.1 MPa | K4520N14160 |
| 0-300 psig / 0-20 bar / 0-2 MPa | K4520N14300 |

For best performance, regulated pressure should always be set by increasing the pressure up to the desired setting.



Global Air Preparation System

Mini Lubricator - P31

Symbols

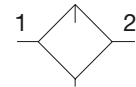

Lubricator with drain

- Integral 1/4" ports (NPT, BSPP & BSPT)
- Robust but lightweight aluminum construction
- Proportional oil delivery over a wide range of air flows
- Finger tip ratchet control for precise oil drip rate adjustment

Options:

| | | | | | | | |
|------------------------------|------------------------------------------------|------------------|-------------------------------------------------------------------------------|-------------------------------|---------------------|----------|----------|
| P 3 1 L | * | | | L | | N | N |
| Engr. level | Thread type | Port size | Bowl type | Drain type | Mounting | | |
| * Will be entered at factory | BSPP 1 BSPT 2 NPT 9 | 1/4 2 | Poly bowl with bowl guard G Metal bowl without sight gauge M | No drain; closed end N | No bracket N | | |
| | Type | | | | | | |
| | Oil mist standard sight dome L | | | | | | |

* Engineering Level will be entered at factory.

| Port size | Description | Order Code† | Flow‡ dm ³ /s (scfm) | Max. bar (psig) | Height mm (inches) | Width mm (inches) | Depth mm (inches) |
|-----------|-----------------------|--------------------|------------------------------------|--------------------|-----------------------|----------------------|----------------------|
| 1/4" | Poly bowl - No drain | P31L*92LGNN | 13 (28) | 10 (150) | 147.5 (5.80) | 40 (1.58) | 42.7 (1.68) |
| 1/4" | Metal bowl - No drain | P31L*92LMNN | 13 (28) | 17 (250) | 147.5 (5.80) | 40 (1.58) | 42.7 (1.68) |

† Standard part numbers shown in bold. For other models refer to Options chart above.

‡ Flow with 6.3 bar (91.3 psig) inlet pressure and 0.34 bar (4.9 psig) pressure drop.

Global Air Preparation System

Specifications

| | | |
|-----------------------|-------------------|---------------------------------|
| Flow Capacity* | 1/4 | 13 dm ³ /s (28 scfm) |
| Operating Temperature | Plastic Bowl | -10°C to 52°C (14°F to 125°F) |
| | Metal Bowl | -10°C to 65.5°C (14°F to 150°F) |
| Max. Supply Pressure | Plastic Bowl | 10 bar (150 psig) |
| | Metal Bowl | 17 bar (250 psig) |
| Useful Retention | | 18 cm ³ (0.6 US oz.) |
| Port Size | BSPP / BSPT / NPT | 1/4 |
| Weight | | 0.13 kg (0.29 lbs) |

* Inlet pressure 6.3 bar (91.3 psig). Pressure drop 0.34 bar (4.9 psig).

Materials of Construction

| | | |
|---------------------|-----------------|---------------|
| Body | Aluminum | |
| Body Cap | ABS | |
| Bowl | Plastic Bowl | Polycarbonate |
| | Metal Bowl | Aluminum |
| Seals | Nitrile | |
| Sight Dome | Polycarbonate | |
| Suggested Lubricant | ISO / ASTM VG32 | |
| Pick-up Filter | Sintered Bronze | |

Flow Charts

1/4 Lubricator

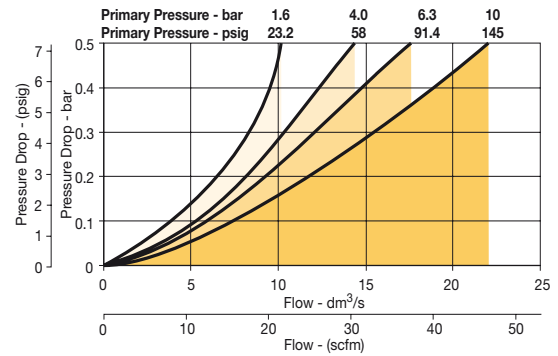

Dimensions mm (inches)

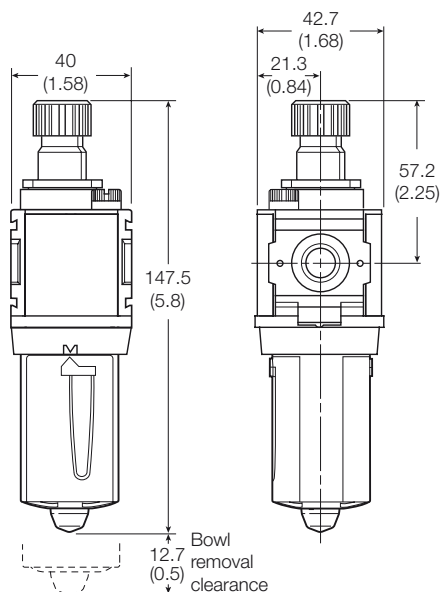

Repair and Service Kits

| | |
|------------------------------------|-------------------|
| Plastic bowl / Bowl guard no drain | P31KA00BGN |
| Drip control assembly | P32KA00PG |
| Fill plug | P31KA00PL |
| C-Bracket (fits to body) | P31KA00MW |
| T-Bracket with body connector | P31KA00MT |
| Body connector | P31KA00CB |

Suggested Lubricant F442 Oil

Petroleum based oil of 100 to 200 SUS viscosity at 38°C (100°F) and an aniline point greater than 93°C (200°F)
 (DO NOT USE OILS WITH ADDITIVES, COMPOUNDED OILS CONTAINING SOLVENTS, GRAPHITE, DETERGENTS, OR SYNTHETIC OILS.)

Global Air Preparation System

Compact Lubricator - P32

Symbols

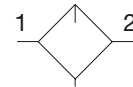

Lubricator with drain

- Integral 1/4", 3/8" or 1/2" ports (NPT, BSPP & BSPT)
- Robust but lightweight aluminum construction
- Proportional oil delivery over a wide range of air flows
- Finger tip ratchet control for precise oil drip rate adjustment
- Fill from top under system pressure

Options:

| | | | | | | | |
|------------------------------|---|--------------------|------------------|---------------------------------------|--|-------------------------------|---------------------|
| P 3 2 L | * | | | L | | N | N |
| Engr. level | | Thread type | Port size | Bowl type | | Drain type | Mounting |
| * Will be entered at factory | | BSPP 1 | 1/4 2 | Poly bowl with bowl guard G | | No drain; closed end N | No bracket N |
| | | BSPT 2 | 3/8 3 | Metal bowl with sight gauge S | | | |
| | | NPT 9 | 1/2 4 | | | | |
| | | | | Type | | | |
| | | | | Oil mist standard sight dome L | | | |

* Engineering Level will be entered at factory.

| Port size | Description | Order Code† | Flow‡ dm ³ /s (scfm) | Max. bar (psig) | Height mm (inches) | Width mm (inches) | Depth mm (inches) |
|-----------|-----------------------|--------------------|------------------------------------|--------------------|-----------------------|----------------------|----------------------|
| 1/4" | Poly bowl - No drain | P32L*92LGNN | 18 (38) | 10 (150) | 211 (8.30) | 60 (2.36) | 60 (2.36) |
| 1/4" | Metal bowl - No drain | P32L*92LSNN | 18 (38) | 17 (250) | 211 (8.30) | 60 (2.36) | 60 (2.36) |
| 3/8" | Poly bowl - No drain | P32L*93LGNN | 32 (68) | 10 (150) | 211 (8.30) | 60 (2.36) | 60 (2.36) |
| 3/8" | Metal bowl - No drain | P32L*93LSNN | 32 (68) | 17 (250) | 211 (8.30) | 60 (2.36) | 60 (2.36) |
| 1/2" | Poly bowl - No drain | P32L*94LGNN | 47 (100) | 10 (150) | 211 (8.30) | 60 (2.36) | 60 (2.36) |
| 1/2" | Metal bowl - No drain | P32L*94LSNN | 47 (100) | 17 (250) | 211 (8.30) | 60 (2.36) | 60 (2.36) |

† Standard part numbers shown in bold. For other models refer to Options chart above.

‡ Flow with 6.3 bar (91.3 psig) inlet pressure and 0.34 bar (4.9 psig) pressure drop.

Global Air Preparation System

Specifications

| | | |
|-----------------------|-------------------|-----------------------------------|
| Flow Capacity* | 1/4 | 18 dm ³ /s (38 scfm) |
| | 3/8 | 32 dm ³ /s (68 scfm) |
| | 1/2 | 47 dm ³ /s (100 scfm) |
| Operating Temperature | Plastic Bowl | -10°C to 52°C (14°F to 125°F) |
| | Metal Bowl | -10°C to 65.5°C (14°F to 150°F) |
| Max. Supply Pressure | Plastic Bowl | 10 bar (150 psig) |
| | Metal Bowl | 17 bar (250 psig) |
| Useful Retention | | 121 cm ³ (4.09 US oz.) |
| Port Size | BSPP / BSPT / NPT | 1/4, 3/8, 1/2 |
| Weight | | 0.31 kg (0.68 lbs) |

* Inlet pressure 6.3 bar (91.3 psig). Pressure drop 0.34 bar (4.9 psig).

Materials of Construction

| | | |
|---------------------|-----------------|---------------|
| Body | Aluminum | |
| Body Cap | ABS | |
| Bowls | Plastic Bowl | Polycarbonate |
| | Metal Bowl | Aluminum |
| Seals | Nitrile | |
| Sight Dome | Polycarbonate | |
| Sight Gauge | Metal Bowl | Polycarbonate |
| Suggested Lubricant | ISO / ASTM VG32 | |
| Pick-up Filter | Sintered Bronze | |

Dimensions mm (inches)

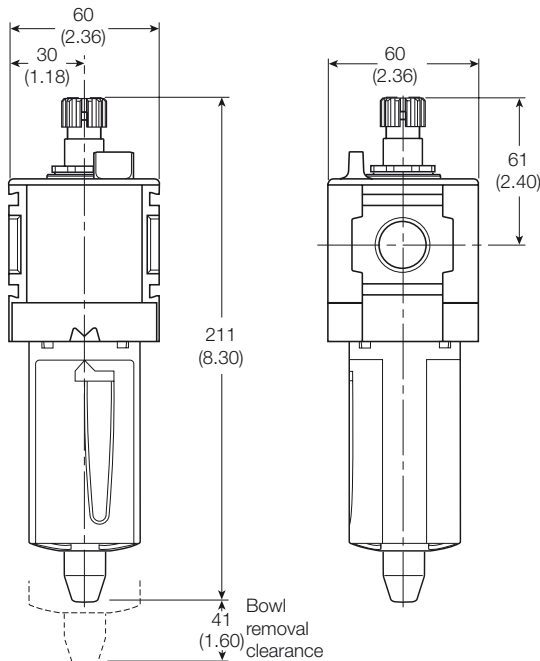

Flow Charts

1/4 Lubricator

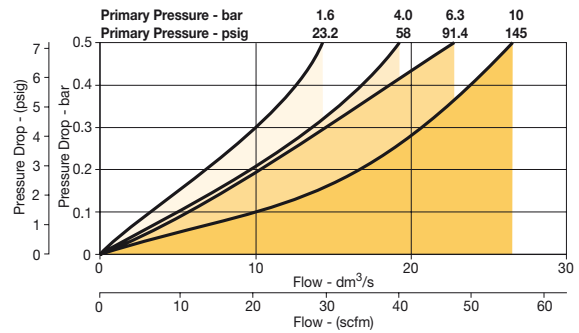

3/8 Lubricator

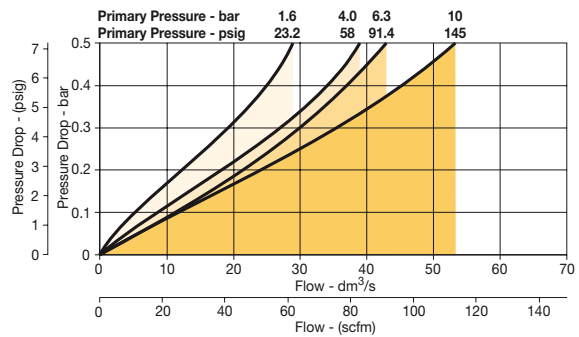

1/2 Lubricator

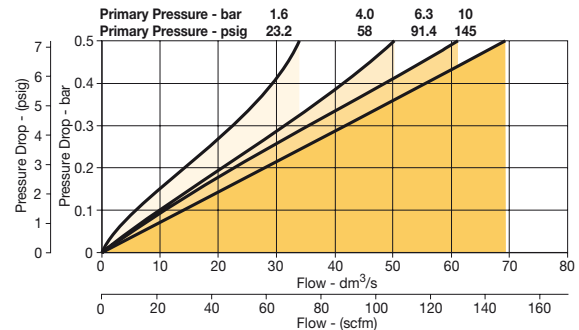

Repair and Service Kits

| | |
|------------------------------------|-------------------|
| Plastic bowl / Bowl guard no drain | P32KA00BGN |
| Drip control assembly | P32KA00PG |
| Fill plug | P32KA00PL |
| L-Bracket (fits to body) | P32KA00ML |
| T-Bracket (fits to body connector) | P32KA00MB |
| T-Bracket with body connector | P32KA00MT |
| Body connector | P32KA00CB |

Suggested Lubricant F442 Oil

Petroleum based oil of 100 to 200 SUS viscosity at 38°C (100°F) and an aniline point greater than 93°C (200°F)
 (DO NOT USE OILS WITH ADDITIVES, COMPOUNDED OILS CONTAINING SOLVENTS, GRAPHITE, DETERGENTS, OR SYNTHETIC OILS.)

Global Air Preparation System

Standard Lubricator - P33

Symbols

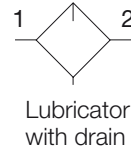

- Integral 1/2" or 3/4" ports (NPT, BSPP & BSPT)
- Robust but lightweight aluminum construction
- Proportional oil delivery over a wide range of air flows
- Finger tip ratchet control for precise oil drip rate adjustment
- Fill from top under system pressure

Options:

| | | | | | | | |
|------------------------------|---|--------------------|------------------|---------------------------------------|--------------------------------------|----------|---------------------|
| P 3 3 L | * | | | L | | N | N |
| Engr. level | | Thread type | Port size | | Bowl type | | Mounting |
| * Will be entered at factory | | BSPP 1 | 1/2 4 | | Poly bowl with bowl guard G | | No bracket N |
| | | BSPT 2 | 3/4 6 | | Metal bowl with sight gauge S | | |
| | | NPT 9 | | | | | |
| | | | | Type | Drain type | | |
| | | | | Oil mist standard sight dome L | No drain; closed end N | | |

* Engineering Level will be entered at factory.

| Port size | Description | Order Code† | Flow‡ dm ³ /s (scfm) | Max. bar (psig) | Height mm (inches) | Width mm (inches) | Depth mm (inches) |
|-----------|-----------------------|--------------------|------------------------------------|--------------------|-----------------------|----------------------|----------------------|
| 1/2" | Poly bowl - No drain | P33L*94LGNN | 48 (102) | 10 (150) | 234 (9.21) | 73 (2.9) | 73 (2.9) |
| 1/2" | Metal bowl - No drain | P33L*94LSNN | 48 (102) | 17 (250) | 234 (9.21) | 73 (2.9) | 73 (2.9) |
| 3/4" | Poly bowl - No drain | P33L*96LGNN | 68 (144) | 10 (150) | 234 (9.21) | 73 (2.9) | 73 (2.9) |
| 3/4" | Metal bowl - No drain | P33L*96LSNN | 68 (144) | 17 (250) | 234 (9.21) | 73 (2.9) | 73 (2.9) |

† Standard part numbers shown in bold. For other models refer to Options chart above.

‡ Flow with 6.3 bar (91.3 psig) inlet pressure and 0.34 bar (4.9 psig) pressure drop.

Global Air Preparation System

Specifications

| | | |
|-----------------------|-------------------|----------------------------------|
| Flow Capacity* | 1/2 | 48 dm ³ /s (102 scfm) |
| | 3/4 | 68 dm ³ /s (144 scfm) |
| Operating Temperature | Plastic Bowl | -10°C to 52°C (14°F to 125°F) |
| | Metal Bowl | -10°C to 65.5°C (14°F to 150°F) |
| Max. Supply Pressure | Plastic Bowl | 10 bar (150 psig) |
| | Metal Bowl | 17 bar (250 psig) |
| Useful Retention | | 181 cm ³ (6.1 US oz.) |
| Port Size | BSPP / BSPT / NPT | 1/2, 3/4 |
| Weight | | 0.47 kg (1.04 lbs) |

* Inlet pressure 6.3 bar (91.3 psig). Pressure drop 0.34 bar (4.9 psig).

Materials of Construction

| | | |
|---------------------|-----------------|---------------|
| Body | Aluminum | |
| Body Cap | ABS | |
| Bowls | Plastic Bowl | Polycarbonate |
| | Metal Bowl | Aluminum |
| Seals | Nitrile | |
| Sight Dome | Polycarbonate | |
| Sight Gauge | Metal Bowl | Polycarbonate |
| Suggested Lubricant | ISO / ASTM VG32 | |
| Pick-up Filter | Sintered Bronze | |

Dimensions mm (inches)

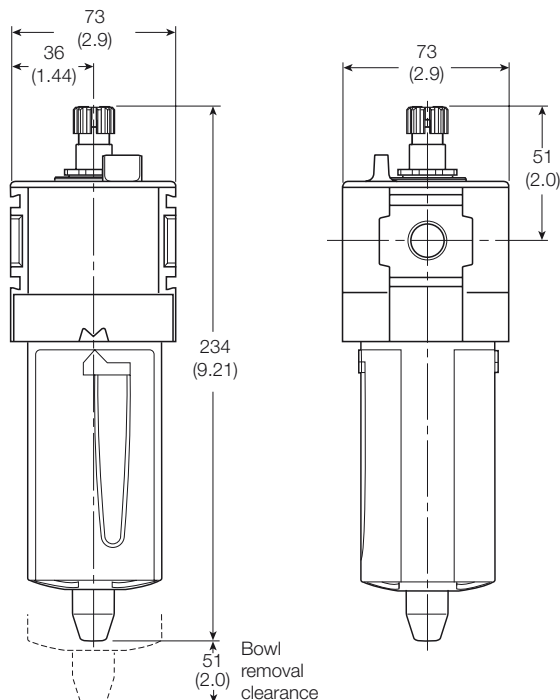

Flow Charts

1/2 Lubricator

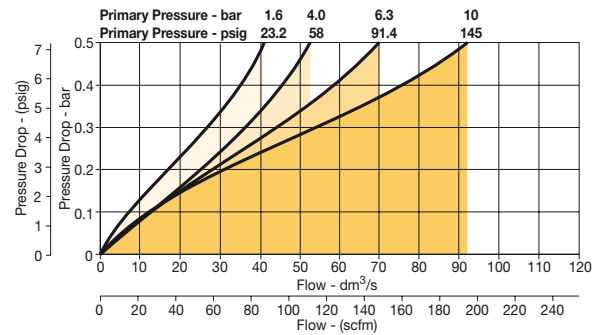

3/4 Lubricator

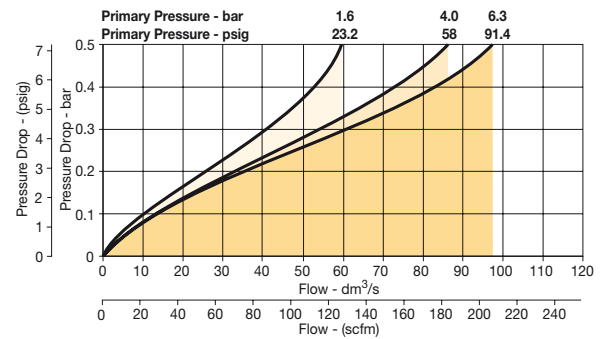

Repair and Service Kits

| | |
|------------------------------------|-------------------|
| Plastic bowl / Bowl guard no drain | P33KA00BGN |
| Drip control assembly | P32KA00PG |
| Fill plug | P32KA00PL |
| L-Bracket (fits to body) | P33KA00ML |
| T-Bracket (fits to body connector) | P32KA00MB |
| T-Bracket with body connector | P32KA00MT |
| Body connector | P32KA00CB |

Suggested Lubricant F442 Oil

Petroleum based oil of 100 to 200 SUS viscosity at 38°C (100°F) and an aniline point greater than 93°C (200°F) (DO NOT USE OILS WITH ADDITIVES, COMPOUNDED OILS CONTAINING SOLVENTS, GRAPHITE, DETERGENTS, OR SYNTHETIC OILS.)

Global Air Preparation System



P31P Series
Bottom exhaust



P32P Series
Bottom exhaust

- Very fast response times
- Accurate output pressure
- Micro parameter settings
- Selectable I/O parameters
- Quick, full flow exhaust
- LED display indicates output pressure
- No air consumption in steady state
- Multiple mounting options
- Protection to IP65
- P31P flows to 19 dm³/s (40 scfm)
- P32P flows to 57 dm³/s (120 scfm)

Order Key

| | | | | | | | |
|----------------------------------------------------------------------------------------------------------|------------|---------------------------------------------------------------------------------------------------------|----------|-------------------------------------------------------------------------------------------------|----------|----------------------------------------------------------------------------------------------------------------------------------------------------------------------------------------------------------------------------------------------------------------------------------------------------------------------------------------------------------------------------------------------------|--|
| P 3 | P * | 1 | A | 2 | 1 | A | |
| Body size Global Mini (1/4") 1 Global Compact (1/2") 2 | | Thread type BSPP 1 BSPT 2 NPT 9 | | Pressure range 0 - 2 bar (0-29 psig) Z 0 - 10 bar (0-145 psig) D | | Output signal Digital, PNP D PNP or 0-10V P NPN or 0-10V N 4-20mA fixed M | |
| Port size Global Mini (1/4") 2 Global Compact (1/2") 4 | | Power supply 24 volts 2 | | Control signal 0-10 V† V | | D) Digital PNP output only, no analog output selectable P) Digital PNP and analogue 0-10V outputs selectable, by means of parameter 6. (Factory default 0-10V) N) Digital NPN and analogue 0-10 V outputs selectable by means of parameter 6. (Factory default 0-10V) M) Analog 4-20mA output only. Note: On all analog outputs the F.S. value can be adjusted by means of parameter 8 | |
| Version Bottom ported exhaust (NC) A Bottom ported forced exhaust (NO)* E | | † Factory setting is 0-10 V control signal. 4-20 mA control signal available via parameter 4 on keypad. | | Input connector M12 (4 pin) 1 | | | |

* When the supply voltage is lost the unit will automatically exhaust the regulated pressure to 0 bar (atmospheric pressure)

* Engineering Level will be entered at factory.

P31P Mounting brackets

| Order Code | Description |
|------------------|---------------------------|
| P3HKA00ML | L-Bracket mounting kit |
| P3HKA00MC | Foot bracket mounting kit |

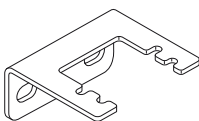

L-Bracket

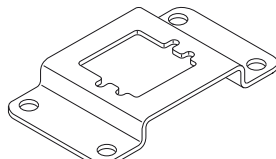

Foot Bracket

P32P Mounting brackets

| Order Code | Description |
|------------------|---------------------------|
| P3KKA00ML | L-Bracket mounting kit |
| P3KKA00MC | Foot bracket mounting kit |

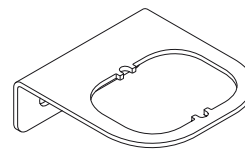

L-Bracket

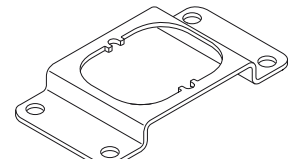

Foot Bracket

Cables

| Order Code | Description |
|---------------------|----------------------------------------------------|
| CB-M12-4P-2M | 2 mtr. cable with moulded straight M12x1 connector |

Note:

These brackets fit both Proportional Regulators and Combined Soft Start & Dump Valves.



Global Air Preparation System

Technical Information

Working medium

Compressed air or inert gasses, filtered to 40µ.

Supply pressure

Max. Operating Pressure:

2 bar unit: 3 bar (43.5 psig)
 10 bar unit: 10.5 bar (152 psig)
 Min. Operating Pressure P2 Pressure + 0.5 bar (7.3 psig)

Pressure control range

Available in three pressure ranges, 0-2 bar (0-29 psig), 0-7 bar (0-101.5 psig) or 0-10 bar (0-145 psig). Pressure range can be changed through the software at all times. (parameter 19)

Temperature range

0°C up to +50°C (32°F up to 122°F)

Weights:

P31P = 0.291 kg (0.64 lbs)
 P32P = 0.645 kg (1.42 lbs)

Air consumption

No consumption in stable regulated situation.

Display

The regulator is provided with a digital display, indicating the output pressure, either in bar or psig. The factory setting is as indicated on the label, can be changed through to software at all times (parameter 14)

Supply voltage

24 VDC +/- 10%

Power consumption

Max. 1.1W with unloaded signal outputs

Control signals

The electronic pressure regulator can be externally controlled through an analogue control signal of either 0-10V or 4-20mA. (parameter 4).

Output signals

As soon as the output pressure is within the signal band a signal is given of 24VDC, PNP Ri = 1 kOhm Outside the signal band this connection is 0V.

Connections

(In case of output signal (Option D))

Central M12 connector 4-pole
 The electrical connections are as follows:

| Pin No. | Function | Color | |
|---------|-----------|----------------------------|-------|
| 1 | 24 V | Supply | Brown |
| 2 | 0 to 10 V | Control Signal Ri = 100k Ω | White |
| | 4 to 20mA | Control Signal Ri = 500 Ω | |
| 3 | 0 V (GND) | Supply | Blue |
| 4 | 24 V | Alarm Output Signal | Black |

Schematic

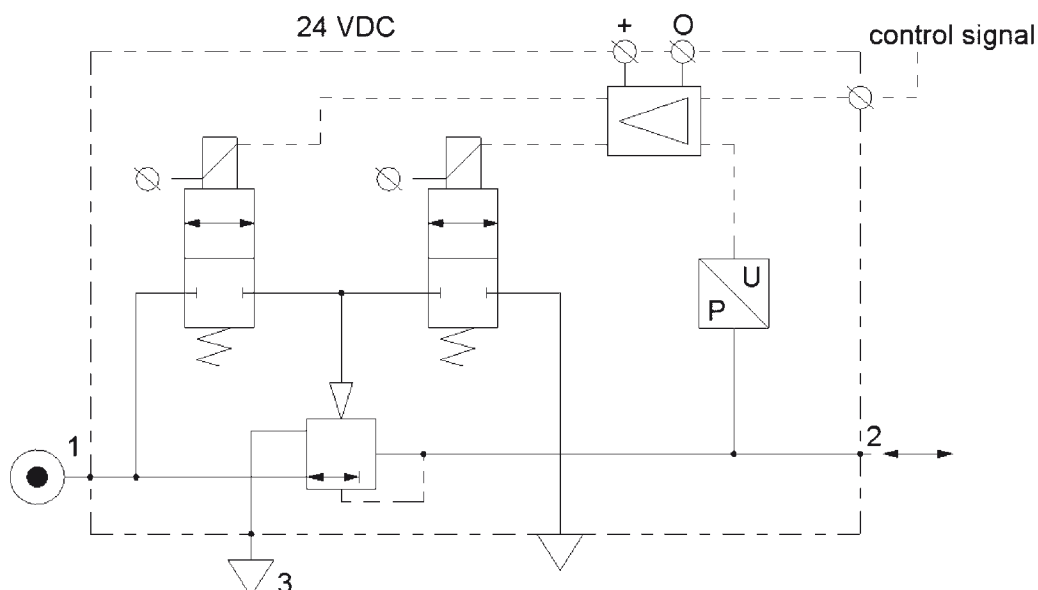

Global Air Preparation System

Technical information

Dead band

The dead band is preset at 1.3% of Full Scale*, adjustable via parameter 13.

Accuracy

Linearity: = < 0.3% of Full Scale.*

Proportional band

The proportional band is preset at 10% of Full Scale.*

Fail safe operation

- If the P31P / P32P unit has an “0” or “A” in the 12th digit of the model number
 - When the supply voltage drops, the electronic control reverts to the fail safe mode. The last known output pressure is maintained at approximately the same level depending upon air consumption. The digital display indicates the last known pressure setting.
 - When the supply voltage is reinstated to the correct level, the valve moves from the fail safe mode and the output pressure immediately follows the control signal requirement. The display indicates the actual output pressure.
 - Note: In the event of loss of both power and inlet pressure the unit will exhaust downstream pressure.
- If the P31P / P32P unit has an “E” in the 12th digit of the model number
 - When the supply voltage drops, the electronic control reverts to “Forced Exhaust Mode” and will automatically exhaust the downstream (regulated) pressure.
 - When the supply voltage is reinstated to the correct level the unit will return to normal operation and follows the control signal requirement. The display indicates the actual pressure.
- If the unit has been programmed in manual mode (not with a control signal) the unit will EXHAUST and the regulator will need to be reset when power is applied.

Full exhaust

Complete exhaust of the regulator is defined as $P2 \leq 1\%$ Full Scale

*** Full scale (F.S.)**

For 2 bar (29 psig) versions this will be 2 bar (29 psig), for the 10 bar (145 psig) version full scale will be 10 bar (145 psig).

Degree of protection

IP65

EU conformity

CE: standard

EMC: according to directive 89/336/EEC

The new pressure regulator is in accordance with:

- EN 61000-6-1:2001
- EN 61000-6-2:2001
- EN 61000-6-3:2001
- EN 61000-6-4:2001

These standards ensure that this unit meets the highest level of EMC protection.

Mounting position

Preferably vertical, with the cable gland on top.

Materials: P31P & P32P

- Magnet Core Steel
- Solenoid Valve Poppet FPM
- Solenoid Valve Housing Techno Polymer
- Regulator Body (P31P & P32P versions) Aluminium
- Regulator Top Housing Nylon
- Valve Head Brass & NBR
- Remaining Seals NBR

Advanced functionality

Pilot valve protection

When the required output pressure can not be achieved because of a lack of input pressure the unit will open fully and will display NoP. Approximately every 10 seconds the unit will retry. The output pressure will then be approximately equal to the inlet pressure. As soon as the input pressure is back on the required level, the normal control function follows.

Safety exhaust

Should the **control signal** fall below 0.1 volts the valve will automatically dump downstream system pressure .

Input protection

The unit has built-in protection against failure and burnout resulting from incorrect input value, typically:

The 24VDC supply is incorrectly connected to the setpoint input, the display will show ‘OL’, as an overload indication. The unit will need to be rewired and when correctly connected will operate normally.

The overload indicator ‘OL’ will also appear should the wrong input value be applied or the wrong input value be programmed: 4 - 20m instead of 0 - 10V. To correct this a different set point value should be input or the unit reprogrammed to correct the set point value acceptance. (via parameter 4).

| Response time | P31P | P32P |
|---------------|----------|-----------|
| 2 to 4 bar | 25 msecs | 35 msecs |
| 1 to 6 bar | 55 msecs | 135 msecs |
| 4 to 2 bar | 70 msecs | 85 msecs |
| 6 to 1 bar | 80 msecs | 225 msecs |

To fill volume of:
 100cm³ - P31P
 330cm³ - P32P
 connected to the outlet of the regulator.

Settings

The regulator is pre-set at the factory. If required, adjustments can be made.

Flow Charts

P31P Regulator 1/4” Ports

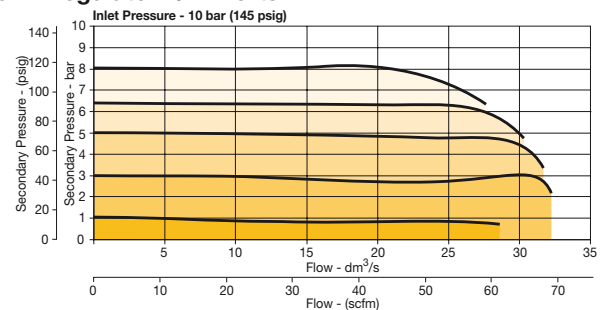

P32P Regulator 1/2” Ports

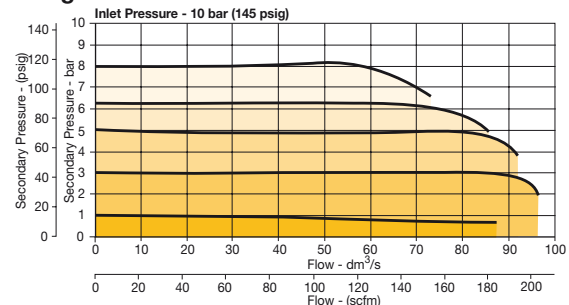

Global Air Preparation System

How to change parameters

Pressing the Accept key “acc” for more than 3 seconds, will activate parameter change mode. The user can then select the parameters by pressing up or down key. (display will show Pxx). When parameter number is correct, pressing accept again will enter parameter number.(display will show parameter value).

Pressing the up or down key will change the parameter itself. (display will flash indicating parameter editing mode). Pressing the accept key will accept the new parameter value. (all digits will flash whilst being accepted).

After releasing all keys , the next parameter number will be presented on the display. (you may step to the next parameter). When no key is pressed, after 3 seconds the display will show the actual output pressure.

When the unit is initially powered up allow approximately 10 seconds for the unit to “boot-up” before changing parameter settings.

Only parameter numbers 0, 4, 6, 8, 9, 14, 18, 19, 20, 12, 13 and 21 are accessible to edit. All other parameters are fixed.

Manual mode:

When keys DOWN and UP are pressed during startup, (connecting to the 24V power supply) manual mode is activated. This means that the user is able to in/decrease the output pressure of the regulator, by pressing the UP or DOWN key. During this action the display will blink, indicating that the manual mode is activated. After powering up again, the unit will revert back to normal mode.















Back to Factory Setting

After start up. (Power is on)

Entering this value in parameter 0 will store the calibrated factory data into the working parameters.

(Default calibration data is used)















Parameter Number 0 – Reset Back to Factory Settings

| Step | 1 | 2 | 3 | 4 | 5 | |
|--------------------------------------------------------------------------------------------|--------------------------------------------------------------------------------------------------|------------------------------------------------------------------------------------------------------------------------------------------------------------------------|---------------------------------------------------------------------------------------------------------|--------------------------------------------------------------------------------------------------------------------------------------------------------------------------|---------------------------------------------------------------------------------------------------|---------------------------------------------------------------------------------------|
| Press  |  3-6 seconds |  or  |  |  or  |  | |
| Until Display Reads |  |  |  Flashing Decimal |  Flashing Decimal |  Flashing |  |
| Description | Accesses changeable parameters. | Accesses parameter no. 0. | Displays current parameter value. | Edits parameter. 3 = standard factory settings. If other than 3, use Up or Down Arrow and accept 3 | Accepts and saves new parameter setting. | Sequences to next parameter. |

Set Control Signal

The unit is factory set for 0-10 V control signal. If 4-20 mA control signal is required, change parameter 4.

Parameter Number 4 – Set Control Signal in Volts or Milliamps

| Step | 1 | 2 | 3 | 4 | 5 | |
|----------------------------------------------------------------------------------------------|----------------------------------------------------------------------------------------------------|----------------------------------------------------------------------------------------------------------------------------------------------------------------------------|---------------------------------------------------------------------------------------------------------|------------------------------------------------------------------------------------------------------------------------------------------------------------------------------|---------------------------------------------------------------------------------------------------|---------------------------------------------------------------------------------------|
| Press  |  3-6 seconds |  or  |  |  or  |  | |
| Until Display Reads |  |  |  Flashing Decimal |  Flashing Decimal |  Flashing |  |
| Description | Accesses changeable parameters. | Accesses parameter no. 4. | Displays current parameter value. 1 = V 0 = mA | Edits parameter. | Accepts and saves new parameter setting. | Sequences to next parameter. |











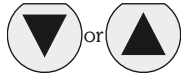

Global Air Preparation System

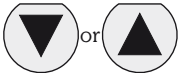
Set Output Signal

Parameter 6 is used to set the type of output signal to your PLC.
This parameter is used as follows:

- Output Signal option “0” = Digital Output – PNP
 - Factory set at “0” Non Adjustable
- Output Signal option “P” = Digital PNP or Analog 1-10V
 - Factory set at “1” for Analog Signal
 - Convert to Digital PNP by changing parameter to “0” setting
- Output Signal option “N” = Digital NPN or Analog 1-10V
 - Factory set at “1” Analog Signal
 - Convert to Digital NPN by changing parameter to “0”
- Output Signal option “M” = Analog 4-20 mA
 - Factory set at “2” Non Adjustable

Parameter Number 6 – Set Output Signal

| Step | 1 | 2 | 3 | 4 | 5 | |
|--------------------------------------------------------------------------------------------|--------------------------------------------------------------------------------------------------|-----------------------------------------------------------------------------------|-------------------------------------------------------------------------------------------------------|-----------------------------------------------------------------------------------------------------------------------------|-------------------------------------------------------------------------------------------------|-------------------------------------------------------------------------------------|
|  Press |  3-6 seconds |  |  |  |  | |
| Until Display Reads |  |  |  Flashing Decimal |  Flashing Decimal (Value 0, 1 or 2) |  Flashing |  |
| Description | Accesses changeable parameters. | Accesses parameter no. 6. | Displays current parameter value. 1 = m factory default for P3H with analog options | Edits parameter. 0 = digital (NPN or PNP) 1 = analog 0..10V 2 = analog 4..20 mA | Accepts and saves new parameter setting. | Sequences to next parameter. |













Adjust Span Analog Output Signal

Set value is a % of Full Analog range. As an example for a 0-10V output signal, the original factory setting of 100% will give you an adjustment of 0-10V. If you reset Parameter 8 to 50%, the new output range would be 0-5V or 50% of the full range.

In the event that the output signal is to low, in a certain application, you can adjust it by increasing Parameter 8 to a maximum value of 130% of scale.

Note that all values are nominal and that an actual measurement may be required to ensure signal strength.

Parameter Number 8 – Adjust Span Analog Output Signal









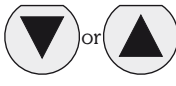

| Step | 1 | 2 | 3 | 4 | 5 | |
|----------------------------------------------------------------------------------------------|----------------------------------------------------------------------------------------------------|-------------------------------------------------------------------------------------|--------------------------------------------------------------------------------------------------------------------------------------------|---------------------------------------------------------------------------------------------------------------------------------------|---------------------------------------------------------------------------------------------------|---------------------------------------------------------------------------------------|
|  Press |  3-6 seconds |  |  |  |  | |
| Until Display Reads |  |  |  Flashing Decimal (For 2 bar versions value = 92) |  Flashing Decimal (Value between 0 and 130) |  Flashing |  |
| Description | Accesses changeable parameters. | Accesses parameter no. 8. | Displays current parameter value. | Edits parameter. | Accepts and saves new parameter setting and implements the new analog signal span. | Sequences to next parameter. |

Global Air Preparation System

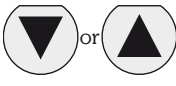
Adjust Digital Display

If necessary, adjustments can be made to the digital display when using an external pressure sensor.



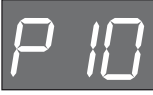







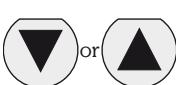

Parameter Number 9 – Adjust Digital Display Value (Pressure Calibration)

| Step | 1 | 2 | 3 | 4 | 5 | |
|---------------------------------------------------------------------------------------------------|--------------------------------------------------------------------------------------------------|-----------------------------------------------------------------------------------|-------------------------------------------------------------------------------------------------------|--------------------------------------------------------------------------------------------------------|-------------------------------------------------------------------------------------------------|-------------------------------------------------------------------------------------|
| Press  |  3-6 seconds |  |  |  |  | |
| Until Display Reads |  |  |  Flashing Decimal |  Flashing Decimal |  Flashing |  |
| Description | Accesses changeable parameters. | Accesses parameter no. 9. | Displays current digital display | Use up or down arrows and accept to adjust the display value if using an external pressure sensor. | Accepts and saves new parameter setting. | Sequences to next parameter. |

Set Pressure Scale

Units with NPT port threads are supplied with a factory set psig pressure scale. Use parameter 14 to change scale to bar.

Parameter Number 14 – Set Pressure Scale in psig or bar









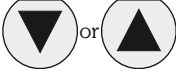

| Step | 1 | 2 | 3 | 4 | 5 | |
|-----------------------------------------------------------------------------------------------------|----------------------------------------------------------------------------------------------------|-------------------------------------------------------------------------------------|---------------------------------------------------------------------------------------------------------|----------------------------------------------------------------------------------------------------------|---------------------------------------------------------------------------------------------------|---------------------------------------------------------------------------------------|
| Press  |  3-6 seconds |  |  |  |  | |
| Until Display Reads |  |  |  Flashing Decimal |  Flashing Decimal |  Flashing |  |
| Description | Accesses changeable parameters. | Accesses parameter no. 14. | Displays current parameter value. 1 = psig 0 = bar 2 = MPA | Edits parameter. | Accepts and saves new parameter setting. | Sequences to next parameter. |

Global Air Preparation System

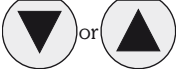
Preset Minimum Pressure

If there is a need for a pre-set Minimum pressure, use parameter 18. (Note: preset pressure is affected by % P19.)

Parameter Number 18 – Set Minimum Preset Pressure

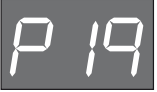
| Step | 1 | 2 | 3 | 4 | 5 | |
|---------------------------------------------------------------------------------------------------|--------------------------------------------------------------------------------------------------|-----------------------------------------------------------------------------------|------------------------------------------------------------------------------------------------------------------------------------------------------|-------------------------------------------------------------------------------------------------------------------------------------|-------------------------------------------------------------------------------------------------|-------------------------------------------------------------------------------------|
| Press  |  3-6 seconds |  |  |  |  | |
| Until Display Reads |  |  |  Flashing Decimal |  Flashing Decimal (value between 0 and 200) |  Flashing |  |
| Description | Accesses changeable parameters. | Accesses parameter no. 18. | Displays current parameter value. Incremental value is: <u>2 bar unit:</u> x 2 mbar x % P19 <u>10 bar unit:</u> x 10 mbar x % P19 | Edits parameter. | Accepts and saves new parameter setting. | Sequences to next parameter. |

Set Pressure Correction













Pressure correction allows the user to set a Maximum pressure as a percentage of secondary pressure F.S.

Example: If F.S. is 10 bar, set parameter 19 to 50 for Maximum preset pressure of 5 bar.

Pressure correction also affects the Minimum preset pressure in parameter 18.

Example: If F.S. is 10 bar and parameter 18 is set to a value of 100 (1 bar), and parameter 19 is set to 50%, then the actual Minimum preset pressure seen is 0.5 bar.

Parameter Number 19 – Set Maximum Preset Pressure

| Step | 1 | 2 | 3 | 4 | 5 | |
|-----------------------------------------------------------------------------------------------------|----------------------------------------------------------------------------------------------------|-------------------------------------------------------------------------------------|---------------------------------------------------------------------------------------------------------|---------------------------------------------------------------------------------------------------------------------------------------|---------------------------------------------------------------------------------------------------|---------------------------------------------------------------------------------------|
| Press  |  3-6 seconds |  |  |  |  | |
| Until Display Reads |  |  |  Flashing Decimal |  Flashing Decimal (value between 0 and 100) |  Flashing |  |
| Description | Accesses changeable parameters. | Accesses parameter no. 19. | Displays current parameter value. Incremental value is: % of F.S. | Edits parameter. | Accepts and saves new parameter setting. | Sequences to next parameter. |











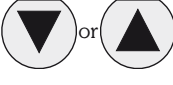

Global Air Preparation System

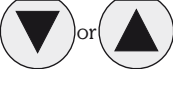
Behavior Control

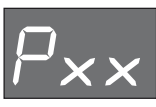
The regulation speed of the pressure regulator can be modified by means of one parameter. (P 20)

The value in this parameter has a range from 0-5. A higher value indicates slower regulation speed, but will be more stable.

Parameter Number 20 – Set Behavior Control

| Step | 1 | 2 | 3 | 4 | 5 | |
|---------------------------------------------------------------------------------------------------|--------------------------------------------------------------------------------------------------|-----------------------------------------------------------------------------------|-------------------------------------------------------------------------------------------------------|----------------------------------------------------------------------------------------------------------------------------------------------------------------|-------------------------------------------------------------------------------------------------|-------------------------------------------------------------------------------------|
| Press  |  3-6 seconds |  |  |  |  | |
| Until Display Reads |  |  |  Flashing Decimal |  Flashing Decimal (value between 0 and 5) |  Flashing |  |
| Description | Accesses changeable parameters. | Accesses parameter no. 20. | Displays current parameter value. | Edits parameter 0 = custom set* 1 = fastest (narrow proportional band) 2 = fast 3 = normal 4 = slow 5 = slowest (proportional band is broad) | Accepts and saves new parameter setting. | Sequences to next parameter. |











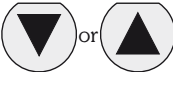

* When the value 0 is entered, you are able to create your own custom settings true parameters 12, 13 and 21.

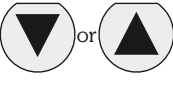
Fine Settings

Set Proportional Band

Proportional band is used for setting the reaction sensitivity of the regulator. The displayed value is X 10 mbar and has a range between 50 (0.5 bar) and 250 (2.5 bar).

Parameter Number 12 – Set Proportional Band (P20 Must be Set to 0)











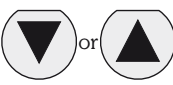

| Step | 1 | 2 | 3 | 4 | 5 | |
|-----------------------------------------------------------------------------------------------------|----------------------------------------------------------------------------------------------------|-------------------------------------------------------------------------------------|---------------------------------------------------------------------------------------------------------|----------------------------------------------------------------------------------------------------------------------------------------|---------------------------------------------------------------------------------------------------|---------------------------------------------------------------------------------------|
| Press  |  3-6 seconds |  |  |  |  | |
| Until Display Reads |  |  |  Flashing Decimal |  Flashing Decimal (value between 50 and 250) |  Flashing |  |
| Description | Accesses changeable parameters. | Accesses parameter no. 12. | Displays current parameter value. Incremental value is: x 10 mbar | Edits parameter. | Accepts and saves new parameter setting. | Sequences to next parameter. |

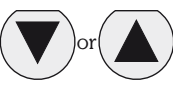
Global Air Preparation System

Set Deadband











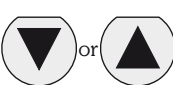

Deadband is the Minimum limit of accuracy at which the regulator is set for normal operation. The displayed value is X 10 mbar and has a range between 4 (40 mbar) and 40 (400 mbar).

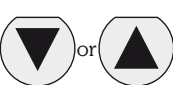
Parameter Number 13 – Set Deadband (P20 Must be Set to 0)







| Step | 1 | 2 | 3 | 4 | 5 | |
|---------------------------------------------------------------------------------------------------|--------------------------------------------------------------------------------------------------|-----------------------------------------------------------------------------------|-------------------------------------------------------------------------------------------------------|------------------------------------------------------------------------------------------------------------------------------------|-------------------------------------------------------------------------------------------------|-------------------------------------------------------------------------------------|
| Press  |  3-6 seconds |  |  |  |  | |
| Until Display Reads |  |  |  Flashing Decimal |  Flashing Decimal (value between 4 and 40) |  Flashing |  |
| Description | Accesses changeable parameters. | Accesses parameter no. 13. | Displays current parameter value. Incremental value is x 10 mbar | Edits parameter. | Accepts and saves new parameter setting. | Sequences to next parameter. |

Proportional Effect

Parameter Number 21 – Set Proportional Effect (P20 Must be Set to 0)

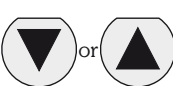
| Step | 1 | 2 | 3 | 4 | 5 | |
|----------------------------------------------------------------------------------------------------|---------------------------------------------------------------------------------------------------|-------------------------------------------------------------------------------------|---------------------------------------------------------------------------------------------------------|---------------------------------------------------------------------------------------------------------------------------------------|---------------------------------------------------------------------------------------------------|---------------------------------------------------------------------------------------|
| Press  |  3-6 seconds |  |  |  |  | |
| Until Display Reads |  |  |  Flashing Decimal |  Flashing Decimal (value between 5 and 100) |  Flashing |  |
| Description | Accesses changeable parameters. | Accesses parameter no. 21. | Displays current parameter value. | Edits parameter. 5 = fastest regulation 100 = slowest regulation. | Accepts and saves new parameter setting. | Sequences to next parameter. |

Parameter Number 39 – Displays Current Software Version

| Step | 1 | 2 | 3 | |
|-----------------------------------------------------------------------------------------------------|----------------------------------------------------------------------------------------------------|-------------------------------------------------------------------------------------|---------------------------------------------------------------------------------------------------------|--|
| Press  |  3-6 seconds |  |  | |
| Until Display Reads |  |  |  Flashing Decimal | |
| Description | Accesses changeable parameters. | Accesses parameter no. 39. | Displays current parameter value. XXX = current software version | |

Global Air Preparation System

P31P

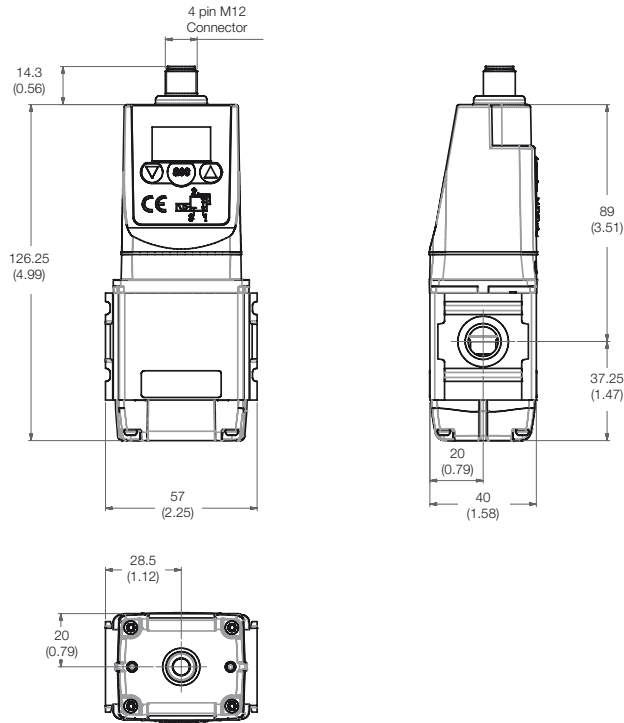

L-Bracket

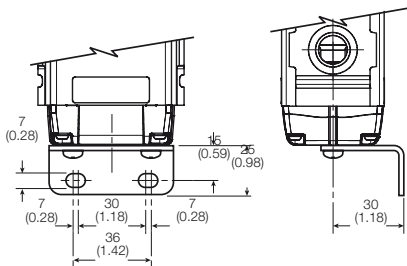

Foot Bracket

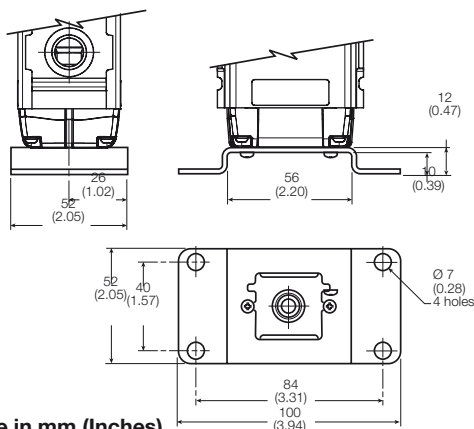

Dimensions are in mm (Inches)

P32P

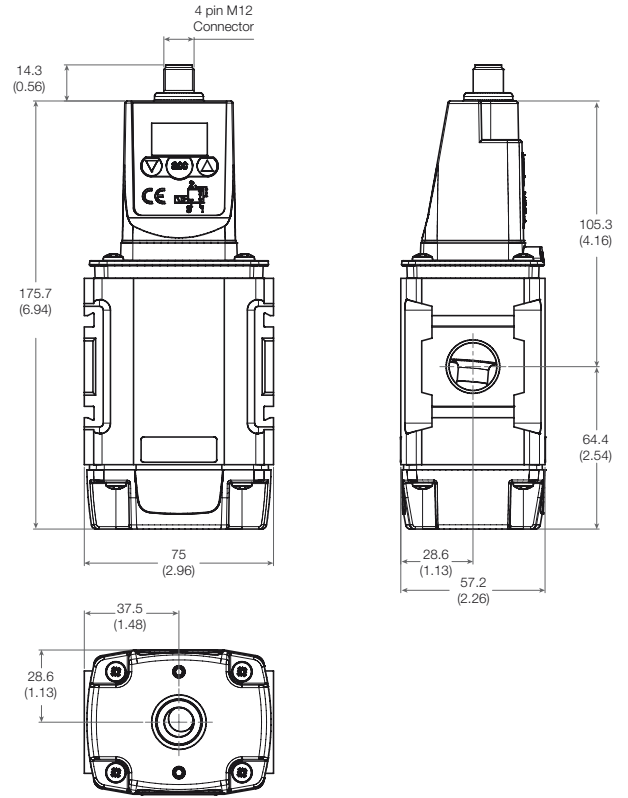

L-Bracket

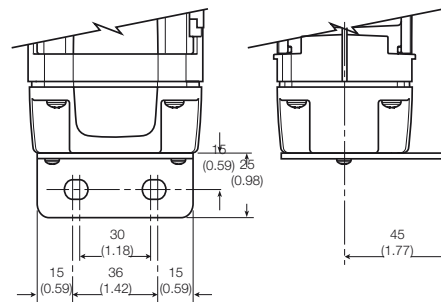

Foot Bracket

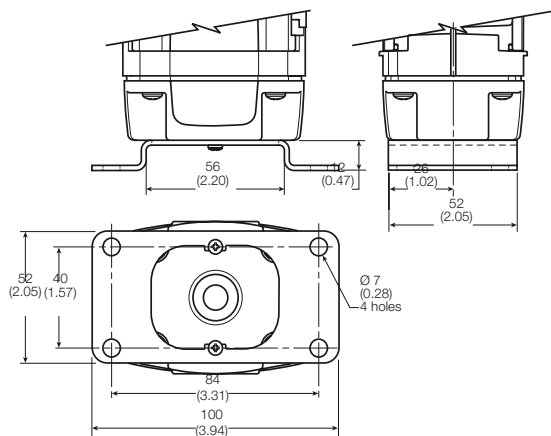

Global Air Preparation System

Combined Soft Start / Dump Valve

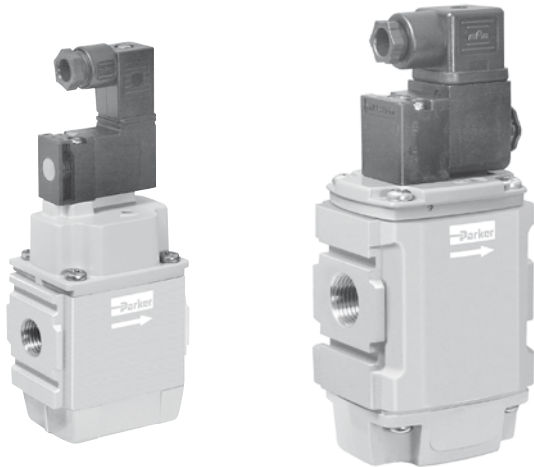

Symbols

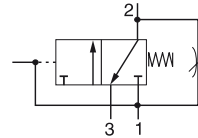

- Modular design with 1/4" or 1/2" integral ports (NPT, BSPP & BSPT)
- Provides for the safe introduction of pressure
- The 3-way, 2-position function automatically dumps downstream pressure on the loss of pilot signal
- Adjustable slow start
- Solenoid or air pilot options
- High flow & exhaust capability
- Silencer included

Parker Global Series Combined Soft Start / Dump Valves, provide for the safe introduction of pressure to machines or systems. Soft Start / Dump Valves when set, allow the pressure to gradually build to the set point before fully opening to deliver full flow at line pressure.

The controlled introduction of pressure can be an important safety factor and prevent damage to tooling when air pressure is introduced at machine or system start up.

To maintain these units in the open position a pilot supply to the air pilot operated version or an electrical signal to the solenoid operated version must be maintained. The valve will automatically dump when the holding signal is removed.

Options:

| | | | | | |
|-------------------------|-----------------------------------|-----------------------------|---------------------------------------------|----------|------------------------------------------------------|
| P 3 | T * | N | Solenoid type only | | |
| Body size | Port size | Pilot type | 15mm (P31 series only) | C | 24VDC non locking manual override |
| Mini (1/4") 1 | Mini (1/4") 2 | External Air Pilot P | 30mm CNOMO coil (P32 only) | A | 120VAC non locking manual override |
| Compact (1/2") 2 | Compact (1/2") 4 | Solenoid Pilot S | 30mm CNOMO coil (M12 connection) (P32 only) | D | 120VAC non locking manual override (P31 series only) |
| Thread Type | Actuator interface | | | | |
| BSPP (G) 1 | 15mm solenoid (P31 only) G | | | | |
| BSPT 2 | 30mm solenoid C | | | | |
| NPT 9 | Threaded air pilot P | | | | |

Note:
P32 unit used for both P32 & P33 series

* Engineering Level will be entered at factory.

Compact combined soft start dump valve

| Port size | Description | Order Code† | Flow‡ dm³/s (scfm) | Max. bar (psig) | Height mm (inches) | Width mm (inches) | Depth mm (inches) | Weight |
|-----------|-------------------------------------|-----------------------|-----------------------|--------------------|-----------------------|----------------------|----------------------|-----------------|
| 1/4" | 120VAC Solenoid & cable plug | P31T*92SGNC1FN | 17 (36) | 10 (150) | 115.6 (4.5) | 57 (2.2) | 40 (1.5) | 0.37kg (0.8lbs) |
| 1/4" | 24VDC Solenoid & cable plug | P31T*92SGNC2CN | 17 (36) | 10 (150) | 166‡ (6.5) | 57 (2.2) | 40 (1.5) | 0.41kg (0.9lbs) |
| 1/4" | External air pilot operated | P31T*92PPN | 17 (36) | 17 (250) | 115.6 (4.5) | 57 (2.2) | 40 (1.5) | 0.37kg (0.8lbs) |
| 1/2" | 120VAC 30mm coil & cable plug incl. | P32T*94SCNA3GN | 46 (97) | 10 (150) | 162.5‡ (6.3) | 88 (3.4) | 57.2 (2.2) | 0.87kg (1.9lbs) |
| 1/2" | 24VDC 30mm coil & cable plug incl. | P32T*94SCNA2CN | 46 (97) | 10 (150) | 227.5‡ (8.9) | 88 (3.4) | 57.2 (2.2) | 0.91kg (2.0lbs) |
| 1/2" | External air pilot operated | P32T*94PPN | 46 (97) | 17 (250) | 162.5‡ (6.3) | 75 (2.9) | 57.2 (2.2) | 0.87kg (1.9lbs) |

‡ Includes exhaust silencer. Flow with 6.3 bar (91.3 psig) inlet and 1 bar (14.5 psig) pressure drop.

† **Standard part numbers shown in bold. For other models refer to Options chart above.**



Global Air Preparation System

Technical Information

| | | |
|-------------------------------------------------------------------|-----------------------------------------|----------------------------------|
| Fluid: | Compressed air | |
| Max. pressure Solenoid operated: | 10 bar (150 psig) | |
| Max. pressure Air Pilot operated: | 17 bar (250 psig) | |
| Min. operating pressure: | 3 bar (44 psig) | |
| Temperature Max.* Solenoid operated: | -10°C to 50°C (14°F to 122°F) | |
| Temperature Max.* Air Pilot operated: | -20°C to 80°C (-4°F to 176°F) | |
| Air Pilot port: | 1/8" | |
| Exhaust port: | P31T - 1/4" / P32T - 1/2" | |
| Typical flow with 6.3 bar inlet pressure and 1 bar pressure drop: | P31T | 17 dm ³ /s (36 scfm) |
| | P32T | 48 dm ³ /s (101 scfm) |

* Air supply must be dry enough to avoid ice formation at temperatures below +2°C
Snap pressure: Full flow when downstream pressure reaches 50% of the inlet pressure

Material Specification

| | |
|-------------|-------------|
| Body: | Aluminum |
| Body cover: | Polyester |
| Seals: | Nitrile NBR |

Mounting Brackets

| | |
|---------------------------|------------------|
| Description | Order code |
| | P31T |
| L-Bracket mounting kit | P3HKA00ML |
| Foot bracket mounting kit | P3HKA00MC |

Note:

For solenoid operators and cable plugs (connectors) see pages 68 to 69.

Dimensions mm (inches)

P31T

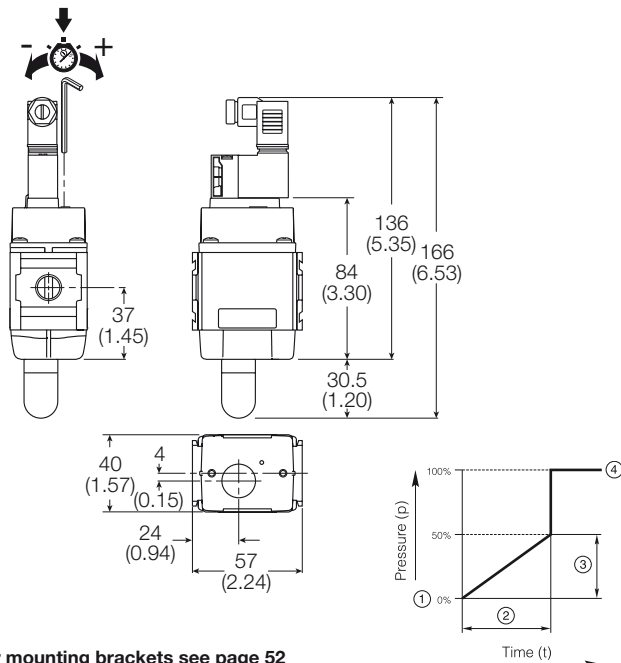

For mounting brackets see page 52

Flow characteristics

1/4 Soft Start & Dump Valve

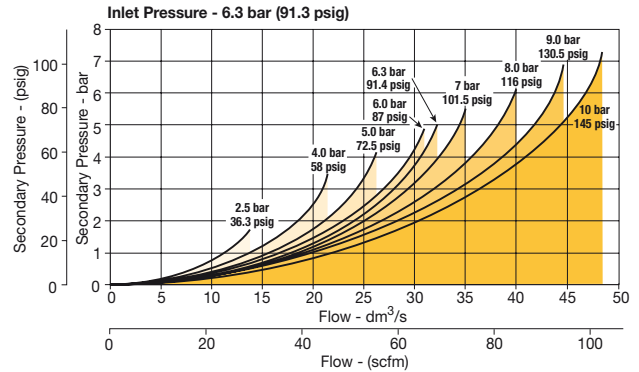

1/2 Soft Start & Dump Valve

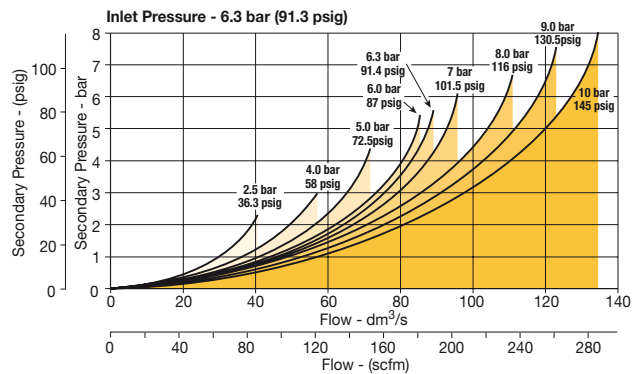

P32T

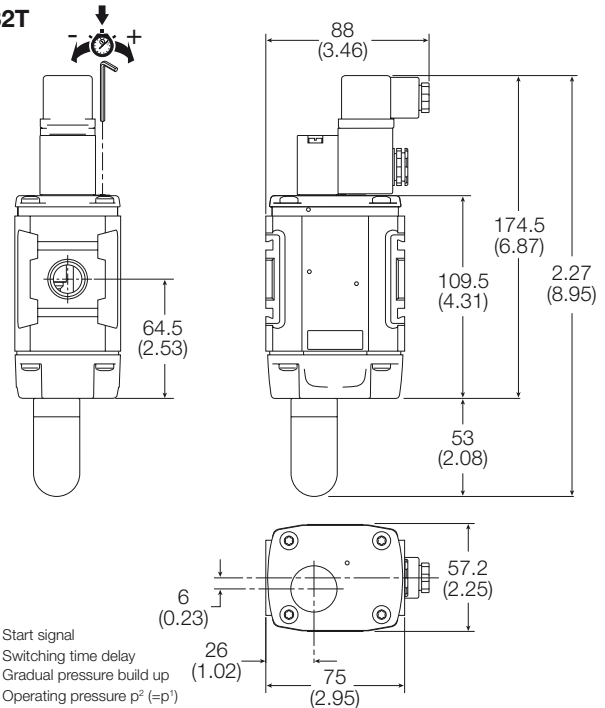

Global Air Preparation System

Dump Valve

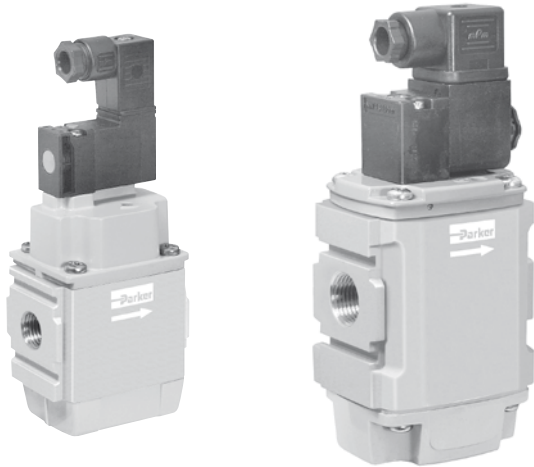

Symbols

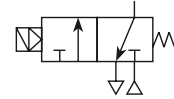

- Modular design with 1/4" or 1/2" integral ports (NPT, BSPP & BSPT)
- Provides for the safe introduction of pressure
- The 3-way, 2-position function automatically dumps downstream pressure on the loss of pilot signal
- Solenoid or air pilot options
- High flow & exhaust capability
- Silencer included

Remotely operated dump valves automatically shut off upstream pressure and exhaust the downstream pressure when the pilot pressure is released.

To maintain these units in the open position a pilot supply to the air pilot operated version or an electrical signal to the solenoid operated version must be maintained. The valve will automatically dump when the holding signal is removed.

Options:

| | | | | |
|-------------------------|-------------------------|-----------------------------------|---------------------------------------------|-----------------------------------------------------------------|
| P 3 | D * | N | Solenoid type only | |
| Body size | Port size | Pilot type | 15mm (P31 series only) | C |
| Mini (1/4") 1 | Mini (1/4") 2 | External Air Pilot P | 30mm CNOMO coil (P32 only) | A |
| Compact (1/2") 2 | Compact (1/2") 4 | Solenoid Pilot S | 30mm CNOMO coil (M12 connection) (P32 only) | D |
| Thread Type | | Actuator interface | | 24VDC non locking manual override 2CN |
| BSPP (G) 1 | | 15mm solenoid (P31 only) G | | 120VAC non locking manual override 3GN |
| BSPT 2 | | 30mm solenoid C | | 120VAC non locking manual override (P31 series only) 1FN |
| NPT 9 | | Threaded air pilot P | | |

Note:
P32 unit used for both P32 & P33 series

* Engineering Level will be entered at factory.

Remote operated dump valve

| Port size | Description | Order Code† | Flow dm ³ /s (scfm) | Max. bar (psig) | Height mm (inches) | Width mm (inches) | Depth mm (inches) | Weight |
|-----------|-------------------------------------|-----------------------|--------------------------------|-----------------|--------------------|-------------------|-------------------|-----------------|
| 1/4" | 120VAC Solenoid & cable plug | P31D*92SGNC1FN | 17 (36) | 10 (150) | 115.6 (4.5) | 57 (2.2) | 40 (1.5) | 0.37kg (0.8lbs) |
| 1/4" | 24VDC Solenoid & cable plug | P31D*92SGNC2CN | 17 (36) | 10 (150) | 166‡ (6.5) | 57 (2.2) | 40 (1.5) | 0.41kg (0.9lbs) |
| 1/4" | External air pilot operated | P31D*92PPN | 17 (36) | 17 (250) | 115.6 (4.5) | 57 (2.2) | 40 (1.5) | 0.37kg (0.8lbs) |
| 1/2" | 120VAC 30mm coil & cable plug incl. | P32D*94SCNA3GN | 51 (108) | 10 (150) | 162.5‡ (6.3) | 75 (2.9) | 57.2 (2.2) | 0.69kg (1.5lbs) |
| 1/2" | 24VDC 30mm coil & cable plug incl. | P32D*94SCNA2CN | 51 (108) | 10 (150) | 227.5‡ (8.9) | 75 (2.9) | 57.2 (2.2) | 0.91kg (2.0lbs) |
| 1/2" | External air pilot operated | P32D*94PPN | 51 (108) | 17 (250) | 162.5‡ (6.3) | 75 (2.9) | 57.2 (2.2) | 0.87kg (1.9lbs) |

‡ Includes exhaust silencer

† Standard part numbers shown in bold. For other models refer to Options chart above.



Global Air Preparation System

Technical Information

| | | |
|-------------------------------------------------------------------|-----------------------------------------|----------------------------------|
| Fluid: | Compressed air | |
| Max. pressure Solenoid operated: | 10 bar (150 psig) | |
| Max. pressure Air Pilot operated: | 17 bar (250 psig) | |
| Min. operating pressure: | 3 bar (44 psig) | |
| Temperature Max.* Solenoid operated: | -10°C to 50°C (14°F to 122°F) | |
| Temperature Max.* Air Pilot operated: | -20°C to 80°C (-4°F to 176°F) | |
| Air Pilot port: | 1/8" | |
| Exhaust port: | P31D - 1/4" / P32D - 1/2" | |
| Typical flow with 6.3 bar inlet pressure and 1 bar pressure drop: | P31D | 17 dm ³ /s (36 scfm) |
| | P32D | 51 dm ³ /s (108 scfm) |

* Air supply must be dry enough to avoid ice formation at temperatures below +2°C
Snap pressure: Full flow when downstream pressure reaches 50% of the inlet pressure

Material Specification

| | |
|-------------|-------------|
| Body: | Aluminum |
| Body cover: | Polyester |
| Seals: | Nitrile NBR |

Mounting Brackets

| | |
|---------------------------|------------------|
| Description | Order code |
| | P31D |
| L-Bracket mounting kit | P3HKA00ML |
| Foot bracket mounting kit | P3HKA00MC |

Note:

For solenoid operators and cable plugs (connectors) see pages 68 to 69.

Dimensions mm (inches)

P31D

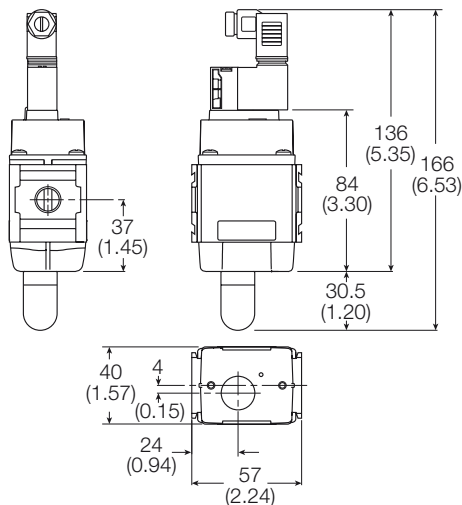

Flow characteristics

1/4 Remote Dump Valve

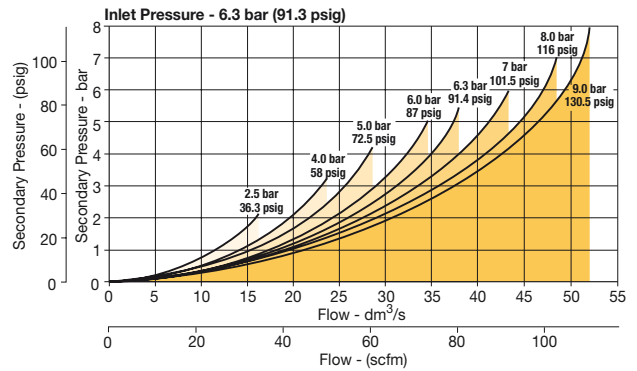

1/2 Remote Dump Valve

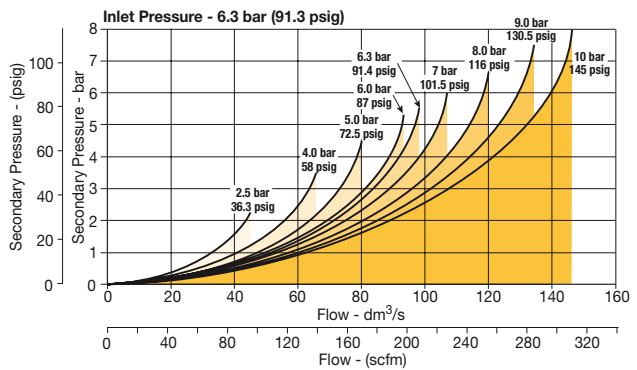

P32D

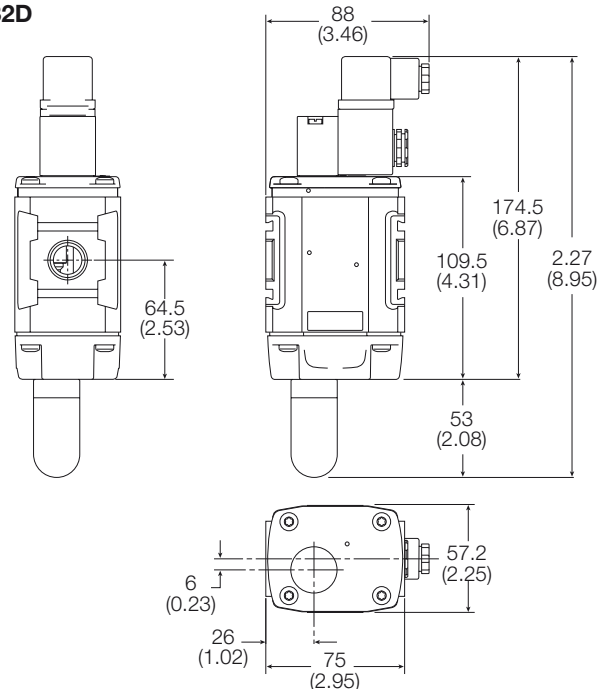

For mounting brackets see page 52



Global Air Preparation System

Soft Start Valve

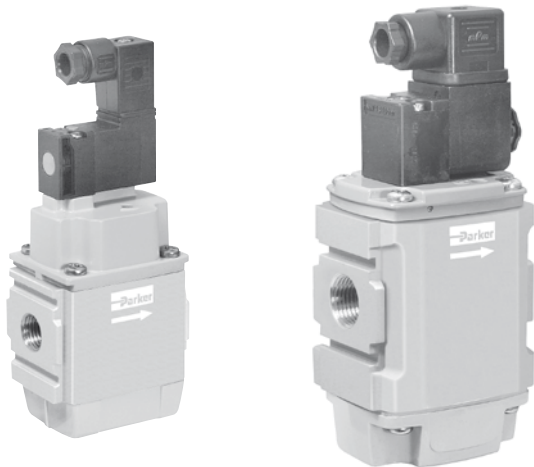

Symbols

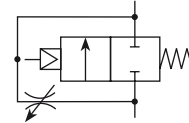

- Modular design with 1/4" or 1/2" integral ports (NPT, BSPP & BSPT)
- The 2-way, 2-position function provides for the safe introduction of pressure
- Adjustable slow start
- Solenoid or air pilot options
- High flow

Parker Global Series Soft Start Valves, provide for the safe introduction of pressure to machines or systems. Soft Start Valves, allow the pressure to gradually build to the set point before fully opening to deliver full flow at line pressure.

The controlled introduction of pressure can be an important safety factor and prevent damage to tooling when air pressure is introduced at machine or system start up.

Note: Soft Start Valves must be installed downstream of a 3/2 valve with exhaust capability

Options:

| | | | | | | | | | | | |
|--------------------|----------|------------------|----------|---------------------------|----------|---------------------------------------------|----------|------------------------------------------------------|------------|-----------------------------------|--|
| P 3 | | S * | | | | N | | | | Solenoid type only | |
| Body size | | Port size | | Pilot type | | 15mm (P31 series only) | | 30mm CNOMO coil (P32 only) | | 24VDC non locking manual override | |
| Mini (1/4") | 1 | Mini (1/4") | 2 | External Air Pilot | P | 30mm CNOMO coil (M12 connection) (P32 only) | A | 120VAC non locking manual override | 2CN | | |
| Compact (1/2") | 2 | Compact (1/2") | 4 | Solenoid Pilot | S | | D | 120VAC non locking manual override | 3GN | | |
| Thread Type | | | | Internal Air Pilot | Y | | | 120VAC non locking manual override (P31 series only) | 1FN | | |
| BSPP (G) | 1 | | | Actuator interface | | | | | | | |
| BSPT | 2 | | | Internal Pilot | O | | | | | | |
| NPT | 9 | | | 15mm solenoid (P31 only) | G | | | | | | |
| | | | | 30mm solenoid | C | | | | | | |
| | | | | Threaded air pilot | P | | | | | | |

Note: P32 unit used for both P32 & P33 series

* Engineering Level will be entered at factory.

Soft start valve

| Port size | Description | Order Code† | Flow dm ³ /s (scfm) | Max. bar (psig) | Height mm (inches) | Width mm (inches) | Depth mm (inches) | Weight |
|-----------|-------------------------------------|-----------------------|--------------------------------|-----------------|--------------------|-------------------|-------------------|-----------------|
| 1/4" | 120VAC Solenoid & cable plug | P31S*92SGNC1FN | 17 (36) | 10 (150) | 115.6 (4.5) | 57 (2.2) | 40 (1.5) | 0.37kg (0.8lbs) |
| 1/4" | 24VDC Solenoid & cable plug | P31S*92SGNC2CN | 17 (36) | 10 (150) | 166.0 (6.5) | 57 (2.2) | 40 (1.5) | 0.41kg (0.9lbs) |
| 1/4" | Internal air pilot operated | P31S*92Y0N | 17 (36) | 17 (250) | 115.6 (4.5) | 57 (2.2) | 40 (1.5) | 0.37kg (0.8lbs) |
| 1/4" | External air pilot (1/8" threaded) | P31S*92PPN | 17 (36) | 17 (250) | 115.6 (4.5) | 57 (2.2) | 40 (1.5) | 0.37kg (0.8lbs) |
| 1/2" | 120VAC 30mm coil & cable plug incl. | P32S*94SCNA3GN | 48 (101) | 10 (150) | 162.5 (6.3) | 88 (3.4) | 57.2 (2.28) | 0.87kg (1.5lbs) |
| 1/2" | 24VDC 30mm coil & cable plug | P32S*94SCNA2CN | 48 (101) | 10 (150) | 227.5 (8.9) | 88 (3.4) | 57.2 (2.28) | 0.90kg (2.0lbs) |
| 1/2" | Internal air pilot operated | P32S*94Y0N | 48 (101) | 17 (250) | 162.5 (6.3) | 75 (2.9) | 57.2 (2.28) | 0.90kg (2.0lbs) |
| 1/2" | External air pilot (1/8 threaded) | P32S*94PPN | 48 (101) | 17 (250) | 162.5 (6.3) | 75 (2.9) | 57.2 (2.28) | 0.87kg (1.5lbs) |

† Standard part numbers shown in bold. For other models refer to Options chart above.



Global Air Preparation System

Technical Information

| | | |
|------------------------------------------------------------------|----------------------------------|----------------------------------|
| Fluid: | Compressed air | |
| Max. pressure Solenoid operated: | 10 bar (150 psig) | |
| Max. pressure Air Pilot operated: | 17 bar (250 psig) | |
| Min. operating pressure: | 3 bar (44 psig) | |
| Temperature Max.* Solenoid operated: | -10°C to 50°C (14°F to 122°F) | |
| Temperature Max.* Air Pilot operated: | -20°C to 80°C (-4°F to 176°F) | |
| Air Pilot port: | 1/8" | |
| Typical flow with 6.3bar inlet pressure and 1 bar pressure drop: | P31S | 17 dm ³ /s (36 scfm) |
| | P32S | 48 dm ³ /s (101 scfm) |

* Air supply must be dry enough to avoid ice formation at temperatures below +2°C
Snap pressure: Full flow when downstream pressure reaches 50% of the inlet pressure

Material Specification

| | |
|-------------|-------------|
| Body: | Aluminum |
| Body cover: | Polyester |
| Seals: | Nitrile NBR |

Mounting Brackets

| Description | Order code |
|---------------------------|------------------|
| | P31S |
| L-Bracket mounting kit | P3HKA00ML |
| Foot bracket mounting kit | P3HKA00MC |

Note:

For solenoid operators and cable plugs (connectors) see pages 68 to 69.

Dimensions mm (inches)

P31S

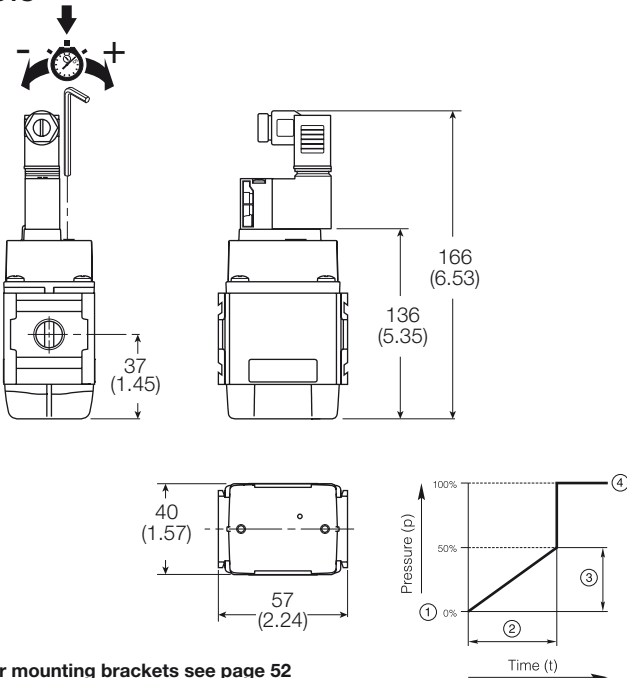

For mounting brackets see page 52

Flow characteristics

1/4 Soft Start Valve

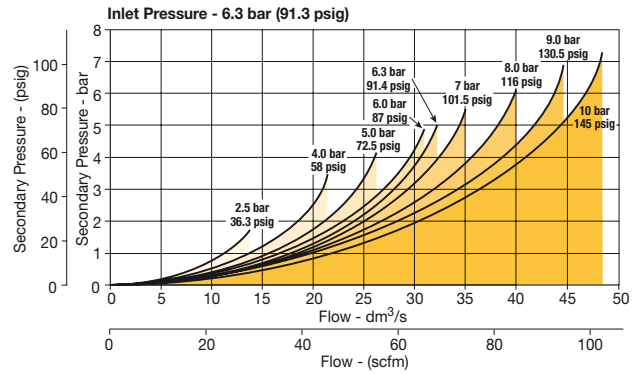

1/2 Soft Start Valve

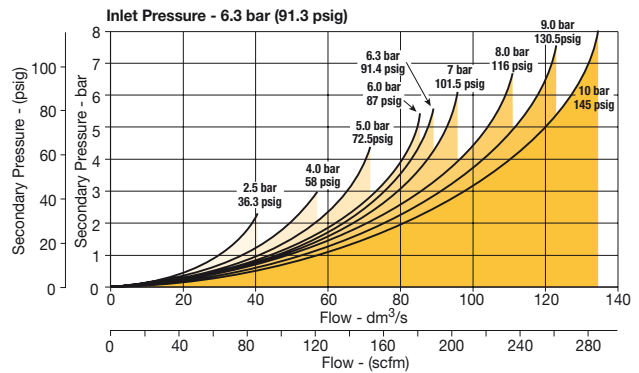

P32S

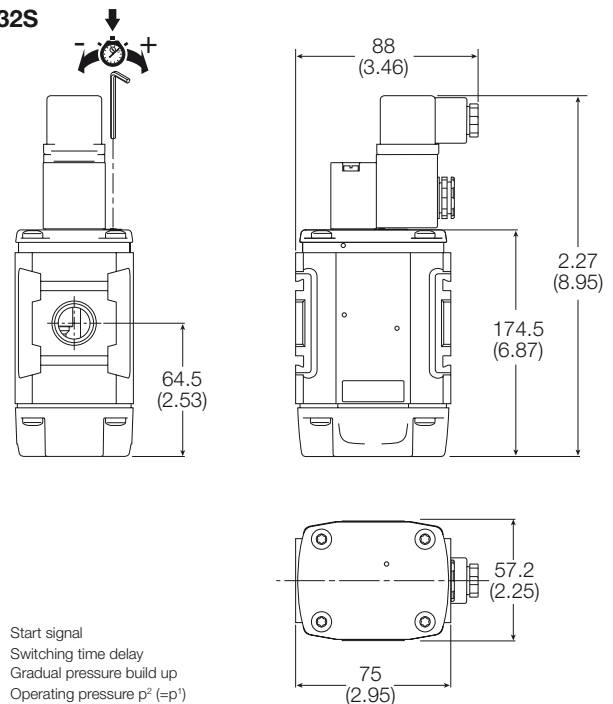

- ① Start signal
- ② Switching time delay
- ③ Gradual pressure build up
- ④ Operating pressure p₂ (=p₁)



Global Air Preparation System

Solenoid Operator - CNOMO

Technical data - Solenoid operators, coil combinations

| | NC Normal Operator with 15mm standard coil | NC Normal Operator with 22 x 30 standard coil | NC Normal Operator with 30 x 30 standard coil |
|---------------------|-----------------------------------------------------------|-----------------------------------------------|-----------------------------------------------|
| Working pressure | 0 to 10 bar | 0 to 10 bar | 0 to 10 bar |
| Ambient temperature | -15°C to 60°C * | -10°C to 60°C * | -10°C to 60°C * |
| Power (DC) | 1.2W | 4.8W | 2.7W |
| Power (AC) | 1.6VA | 8.5VA | 4.9VA |
| Voltage tolerance | +10%/-15% | +/-10% | +/-10% |
| Duty cycle | 100% | 100% | 100% |
| Insulation class | F | F | F |
| Electric connection | ISO 15217 | B Industrial | DIN 43650A |
| Protection | IP65 | IP65 | IP65 |
| Approval | UL/CSA | | UL/CSA |
| Working media | All neutral media such as compressed air and inert gases. | | |

* limited to 50°C if use with 100% duty cycle

Transients

Interrupting the current through the solenoid coil produces momentary voltage peaks which, under unfavourable conditions, can amount to several hundred times the rated operating voltage. Normally, these transients do not cause problems, but to achieve the Maximum life of relays in the circuit (and particularly of transistors, thyristors and integrated circuits) it is desirable to provide protection by means of voltage-dependent resistors (varistors). All connectors/cable plugs EN175301-803 with LED's include this type of circuit protection.

Materials

Pilot Valve

| | |
|-----------------|---------------------------------|
| Body: | Polyamide |
| Armature tube: | Brass |
| Plunger & core: | Corrosion resistant Cr-Ni steel |
| Seals: | Fluorocarbon |
| Screws: | Stainless steel |

Coil

| | |
|-------------------------|-----------------------------------------------------------|
| Encapsulation material: | Thermoplastic as standard Duroplast for M12 connection |
|-------------------------|-----------------------------------------------------------|

P31 Series only - Solenoid coils 15mm NC

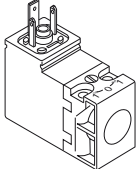
|  | Voltage | Order code Override, blue, non locking flush | Weight (Kg) |
|-------------------------------------------------------------------------------------|-------------------|----------------------------------------------------|----------------|
| | 24VDC | PS2982B49P | 0.038 |
| 115VAC 50Hz / 120VAC 60Hz | PS2982B53P | 0.038 | |

Spare solenoid operators

Base Solenoid pilot operator CNOMO NC

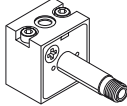
|  | Description | Order code Non-lock manual override | Weight (Kg) |
|-------------------------------------------------------------------------------------|------------------|-------------------------------------------|----------------|
| | Standard Duty | P2FP23N4B | 0.065 |
| No Override | P2FP23N4A | 0.065 | |

Note: Solenoid pilot operators are fitted to the Global range. Order the above part numbers for spares. The operators are supplied with mounting screws and interface 'O' rings. **Coils and connectors must be ordered separately.**

Solenoid coils with M12 connection

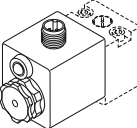
|  | Voltage | Order code | Weight (Kg) |
|-------------------------------------------------------------------------------------|----------------|------------|-----------------|
| | Direct current | 24VDC | P2FC6449 |

Solenoid coils with Din A or Industrial B connection

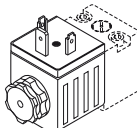
|  | Voltage | 22mm x 30mm Order code B Industrial Standard | Weight (Kg) | 30mm x 30mm Order code DIN 43650A Standard | Weight (Kg) |
|-------------------------------------------------------------------------------------|----------------------|----------------------------------------------------|-----------------|-----------------------------------------------------|-----------------|
| | Direct current | 24VDC | P2FCB449 | 0.093 | P2FCA449 |
| Alternative current | 110V 50Hz, 120V 60Hz | P2FCB453 | 0.093 | P2FCA453 | 0.105 |

Global Air Preparation System

Solenoid connectors / Cable plugs EN175301-803

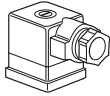
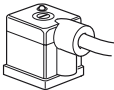
| | Description | Order code 15mm Form C ISO15217 | Order code 22mm Form B Industrial | Order code 30mm Form A DIN 43650A |
|----------------------------------------------------------------------------------------------------------|---------------------------------------------|---------------------------------------|-----------------------------------------|-----------------------------------------|
| With standard screw  | Standard IP65 without flying lead | PS2932BP | PS2429BP | PS2028BP |
| | With LED and protection 24VAC/DC | PS294679BP | PS243079BP | PS203279BP |
| | With LED and protection 110VAC | PS294683BP | PS243083BP | PS203283BP |
| With cable  | Standard with 2m cable IP65 | PS2932JBP | PS2429JBP | PS2028JCP |
| | 24VAC/DC, 2m cable LED and protection IP65 | PS2946J79BP | PS2430J79BP | PS2032J79CP |
| | 110VAC/DC, 2m cable LED and protection IP65 | PS2946J83BP | PS2430J83BP | PS2032J83CP |

Solenoid coil

Dimensions mm (inches)

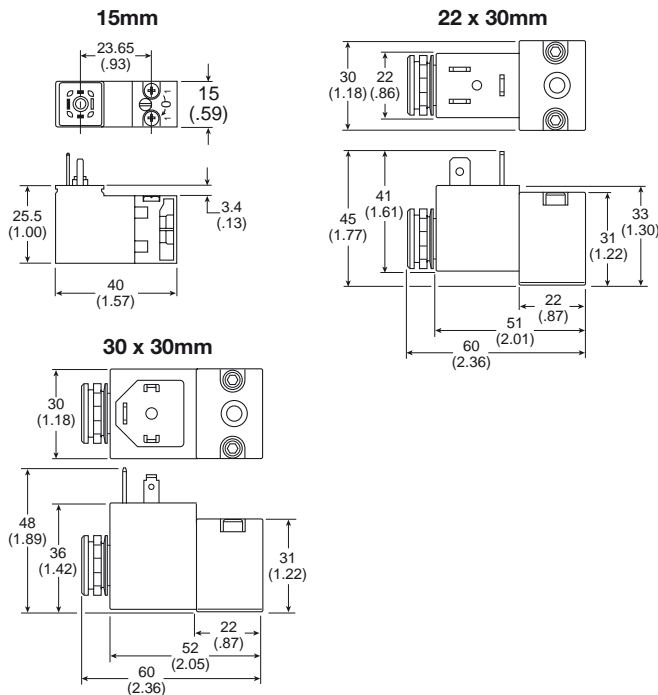

Electrical schematics



| | | |
|------------------|--------------------|--------------------|
| PS2028BP | PS243079BP | PS203279BP |
| PS2028JCP | PS2430J79BP | PS2032J79CP |
| PS2429BP | PS243083BP | PS203283BP |
| PS2429JBP | PS2430J83BP | PS2032J83CP |
| PS2932BP | PS294679BP | PS294683BP |
| PS2932JBP | PS2946J79BP | PS2946J83BP |

Cable plug

Dimensions mm (inches)

15mm ISO 15217
Cable plugs

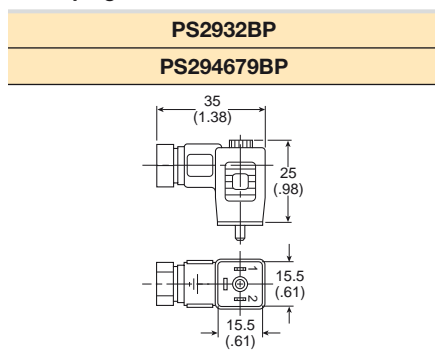

22mm Form B Industrial
Cable plugs

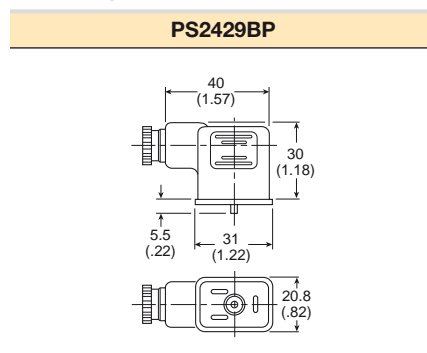

30mm DIN 43650A
Cable plugs

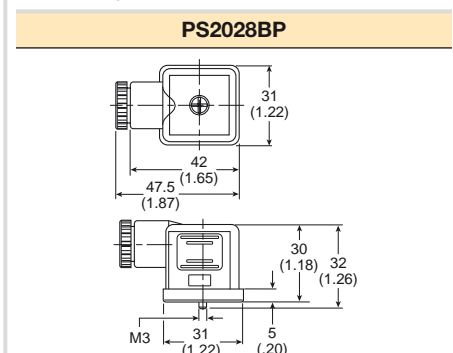

Global Air Preparation System

Safety Lockout Valves

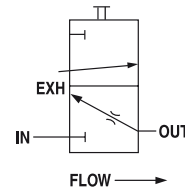
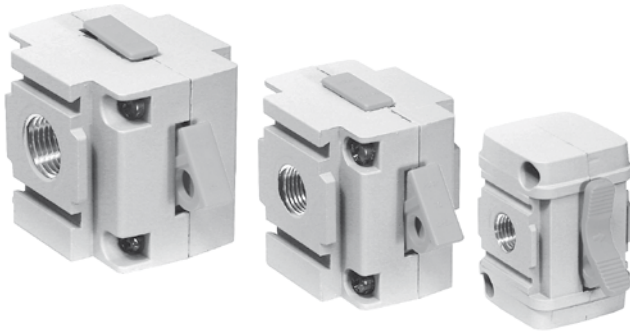

Features

- The Safety Lockout valve is a manually operated, slide-type, 2-position, 3-way valve. In the closed position, downstream air pressure is exhausted to atmosphere.
- The valve slide can be locked in the closed position with a customer supplied padlock.
- The Safety Lockout valves conform to OSHA #29 CFR part 1910 – control of hazardous energy source (lockout / tagout).
- Left to right flow — orange slide
- Right to left — yellow slide

Ordering Information

| Model type | Port size | Thread type | Flow dm ³ /s (scfm) | Safety Lockout Valve Flow from left to right | Safety Lockout Valve Flow from right to left |
|------------|-----------|-------------|--------------------------------|-----------------------------------------------------|-----------------------------------------------------|
| P31 | 1/4" | NPT | 47.2 (100) | P31V*92LSAN | — |
| P32 | 1/4" | NPT | 66.5 (141) | P32V*92LSAN | P32V*92LSBN |
| | 3/8" | NPT | 101.9 (216) | P32V*93LSAN | P32V*93LSBN |
| | 1/2" | NPT | 128.4 (272) | P32V*94LSAN | P32V*94LSBN |
| P33 | 1/2" | NPT | 136.9 (290) | P33V*94LSAN | P33V*94LSBN |
| | 3/4" | NPT | 141.6 (300) | P33V*96LSAN | P33V*96LSBN |

For thread type: BSPP **1**
 BSPT **2**
 NPT **9**

* Engineering Level will be entered at factory.

Materials of Construction

| | |
|-------|---------|
| Body | Zinc |
| Blade | Acetal |
| Seals | Nitrile |

Specifications

| | |
|-----------------------|----------------------------------------------------------------------------------------------------|
| Operating temperature | P31: -10°C to 65.5°C (14°F to 150°F) P32/P33: -25°C to 65.5°C (-13°F to 150°F) |
| Max. supply pressure | 10 bar (150 psig) |
| Port size | BSPP / BSPT / NPT 1/4, 3/8, 1/2, 3/4 |
| Weight | P31: 0.30 kg (0.66 lbs) P32: 0.34 kg (0.74 lbs) P33: 0.41 kg (0.90 lbs) |

Dimensions mm (inches)

P31

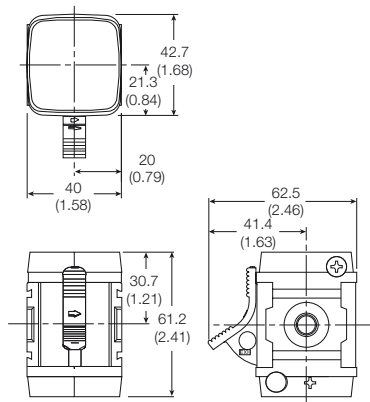

P32

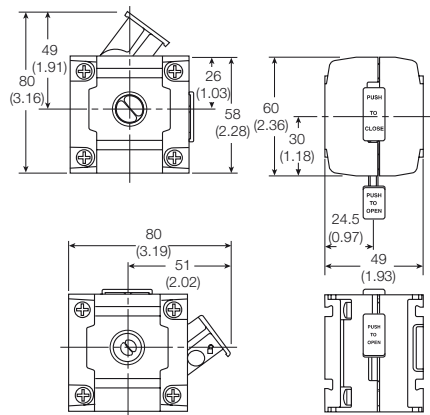

P33

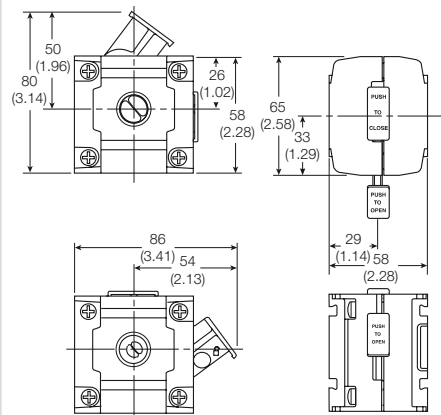

Global Air Preparation System

Modular Ball Valves

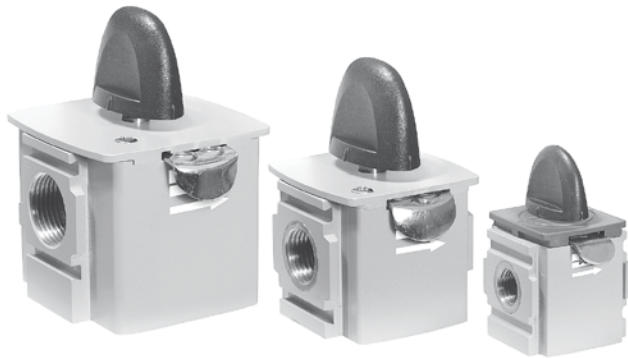
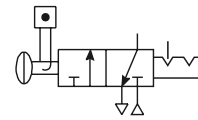

Features

The Modular Ball Valves provide shut off line pressure with a non-sticking 90° turn handle to prevent unauthorised adjustment. When the inlet pressure is turned off the downstream air pressure vents through the exhaust port. The padlock slide may be assembled on either side. It is recommended that this is assembled after mounting.

Note: This padlock slide is a permanent assembly and may not be removed later

Ordering Information

| Model type | Port size | Exhaust port | Thread type | Flow dm ³ /s (scfm) | Modular ball valve flow from left to right |
|------------|-----------|--------------|-------------|--------------------------------|--------------------------------------------|
| P31 | 1/4" | 1/4" | NPT | 20 (42.4) | P31V*92LBNN |
| P32 | 3/8" | 1/4" | NPT | 90 (190.7) | P32V*93LBNN |
| | 1/2" | 1/4" | NPT | 122 (258.5) | P32V*94LBNN |
| P33 | 1/2" | 1/2" | NPT | 265 (561.5) | P33V*94LBNN |
| | 3/4" | 1/2" | NPT | 320 (678) | P33V*96LBNN |

* Engineering Level will be entered at factory.

For thread type: BSPP **1**
 BSPT **2**
 NPT **9**

Specifications

| | | |
|-----------------------|-------------------------------|--------------------|
| Operating temperature | -20°C to 80°C (-4°F to 176°F) | |
| Max. supply pressure | 17 bar (250 psig) | |
| Port size | BSPP / BSPT / NPT | 1/4, 3/8, 1/2, 3/4 |
| Weight | P31: | 0.19 kg (0.41 lbs) |
| | P32: | 0.47 kg (1.00 lbs) |
| | P33: | 0.80 kg (1.70 lbs) |

Materials of Construction

| | |
|-------|--------------------------------------|
| Body | Aluminum |
| Seals | PTFE |
| Ball | P31 Brass |
| | P32 / P33 Chrome plated brass |

Dimensions mm (inches)

P31

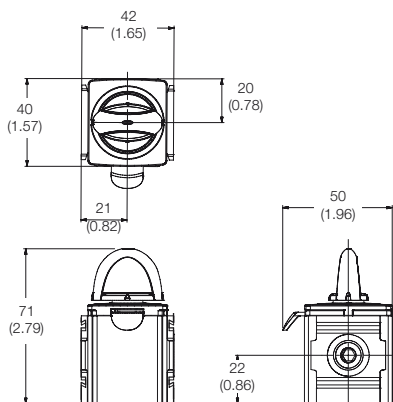

P32

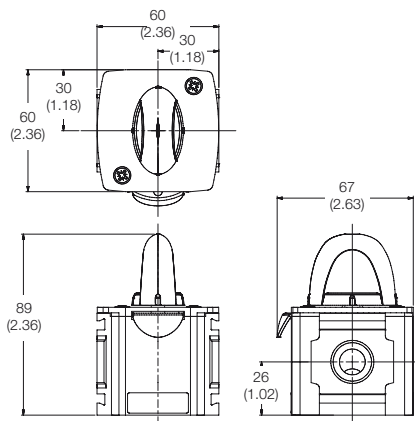

P33

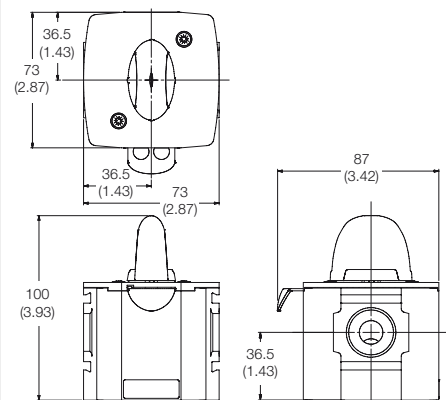

Global Air Preparation System

Manifold Blocks

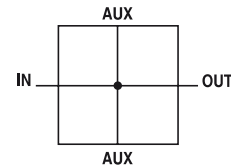

Features

- Available in 1/4" or 3/4" threaded inlet / outlet ports
- Two additional top and bottom auxiliary ports standard
- Can be mounted anywhere in the FRL system
- Includes one pipe plug

Ordering Information

| Model type | In / Out port size | Auxiliary port size top | Auxiliary port size bottom | Thread type | Order Code |
|------------|--------------------|-------------------------|----------------------------|-------------|--------------------|
| P31 | 1/4" | 1/4" | 1/4" | NPT | P31M*92022N |
| P32 | 1/2" | 1/4" | 1/2" | NPT | P32M*94024N |
| P33 | 3/4" | 1/4" | 1/2" | NPT | P33M*96024N |

* Engineering Level will be entered at factory.

For thread type: BSPP **1**
 BSPT **2**
 NPT **9**

Specifications

| | | |
|-----------------------|----------------------------------|--------------------|
| Operating temperature | -40°C to 65.5°C (-40°F to 150°F) | |
| Max. supply pressure | 20.7 bar (300 psig) | |
| Weight | P31: | 0.19 kg (0.26 lbs) |
| | P33: | 0.34 kg (0.42 lbs) |

Materials of Construction

Body Aluminum

Note:

P33 unit used for both P32 & P33 series

Dimensions mm (inches)

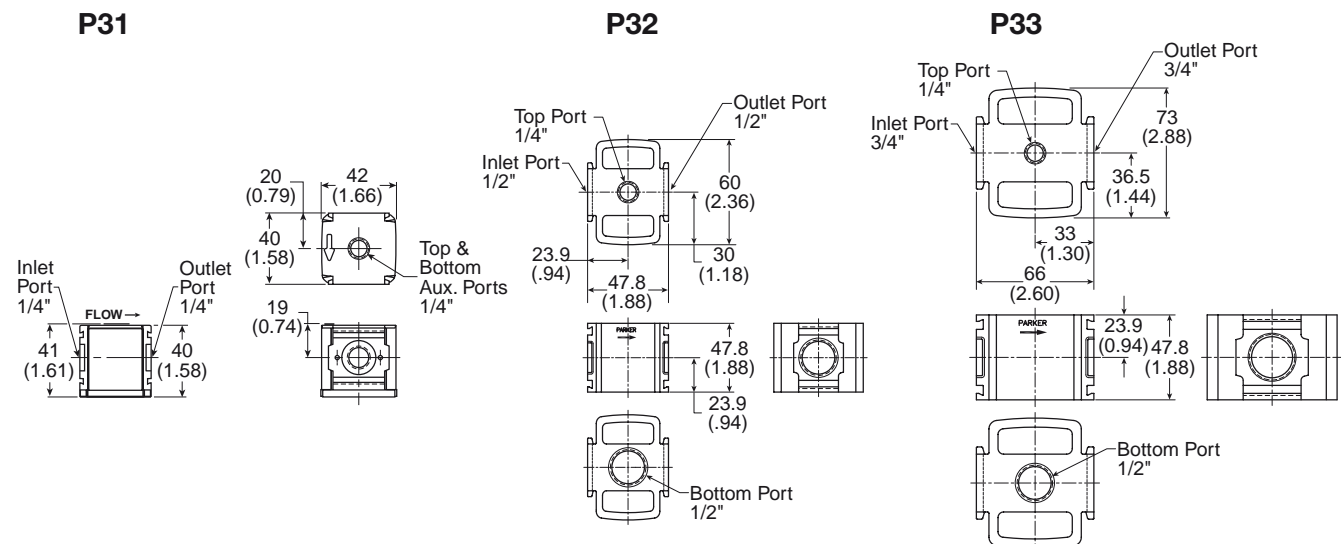

Global Air Preparation System

Accessories - P31 Series

C-Bracket

(Fits to filter and lubricator body)

P31KA00MW

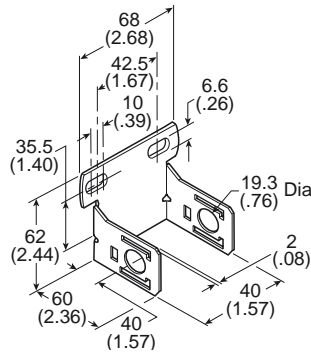

T-Bracket w/ Body Connector

(O-ring not shown)

P31KA00MT

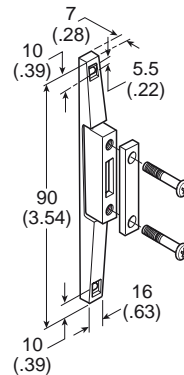

Body Connector

(O-ring not shown)

P31KA00CB

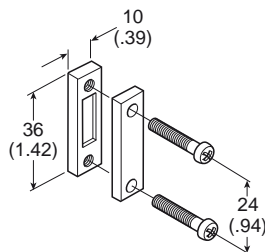

Port Block Kit

(O-ring not shown)

- | | | | |
|----------------|------------------|----------------|------------------|
| 1/8 NPT | P31KA91CP | 1/8 BSPT | P31KA21CP |
| 1/4 NPT | P31KA92CP | 1/4 BSPT | P31KA22CP |
| 3/8 NPT | P31KA93CP | 3/8 BSPT | P31KA23CP |
| 1/8 BSPP | P31KA11CP | | |
| 1/4 BSPP | P31KA12CP | | |
| 3/8 BSPP | P31KA13CP | | |



Port Block Kit w/ T-Bracket

(O-ring not shown)

- | | | | |
|----------------|------------------|----------------|------------------|
| 1/8 NPT | P31KA91CN | 1/8 BSPT | P31KA21CN |
| 1/4 NPT | P31KA92CN | 1/4 BSPT | P31KA22CN |
| 3/8 NPT | P31KA93CN | 3/8 BSPT | P31KA23CN |
| 1/8 BSPP | P31KA11CN | | |
| 1/4 BSPP | P31KA12CN | | |
| 3/8 BSPP | P31KA13CN | | |



Angle Bracket

(Fits to regulator and filter/regulator body)

P31KA00MR

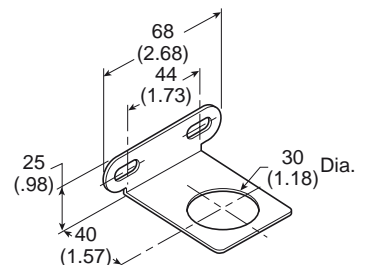

Global Air Preparation System

Accessories - P32 Series

T-Bracket w/ Body Connector

P32KA00MT

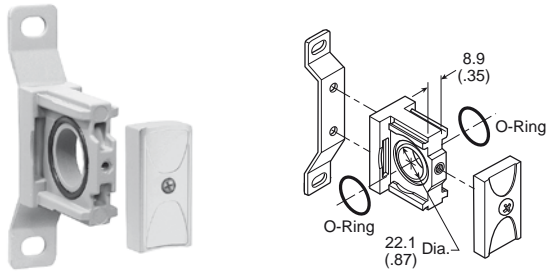

Body Connector

P32KA00CB

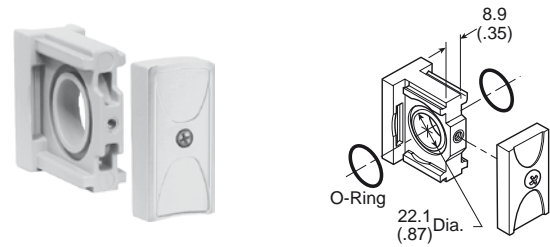

Port Block Kit

- | | | | |
|----------------|------------------|----------------|------------------|
| 1/4 NPT..... | P32KA92CP | 1/4 BSPT | P32KA22CP |
| 3/8 NPT..... | P32KA93CP | 3/8 BSPT | P32KA23CP |
| 1/2 NPT..... | P32KA94CP | 1/2 BSPT | P32KA24CP |
| 3/4 NPT..... | P32KA96CP | 3/4 BSPT | P32KA26CP |
| 1/4 BSPP | P32KA12CP | | |
| 3/8 BSPP | P32KA13CP | | |
| 1/2 BSPP | P32KA14CP | | |
| 3/4 BSPP | P32KA16CP | | |



Angle Bracket

(Fits to regulator and filter/regulator bonnet)

P32KA00MR

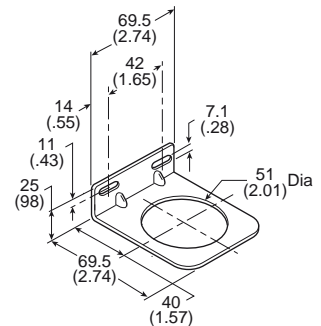

L-Bracket

(Fits to filter and lubricator body)

P32KA00ML

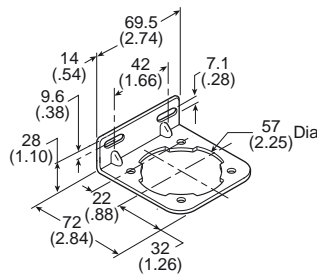

T-Bracket

(fits to body connector or port block)

P32KA00MB

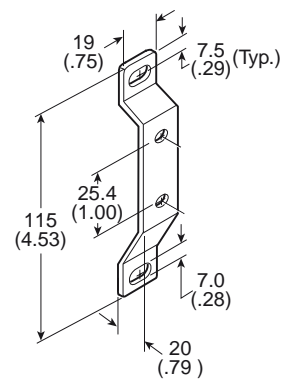

Global Air Preparation System

Accessories - P33 Series

T-Bracket w/ Body Connector

P32KA00MT

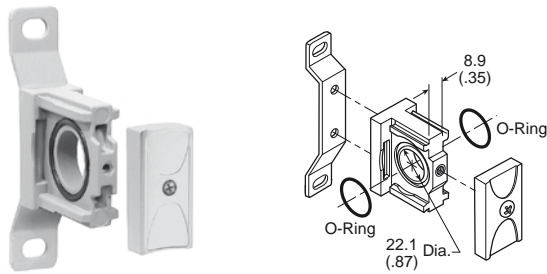

Body Connector

P32KA00CB

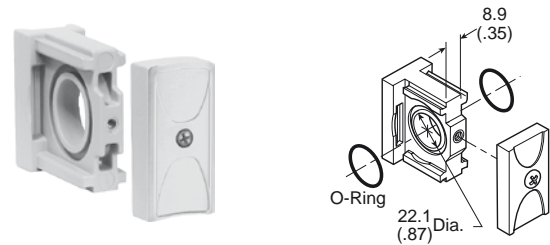

Port Block Kit

- | | | | |
|----------------|------------------|----------------|------------------|
| 1/4 NPT..... | P32KA92CP | 1/4 BSPT | P32KA22CP |
| 3/8 NPT..... | P32KA93CP | 3/8 BSPT | P32KA23CP |
| 1/2 NPT..... | P32KA94CP | 1/2 BSPT | P32KA24CP |
| 3/4 NPT..... | P32KA96CP | 3/4 BSPT | P32KA26CP |
| 1/4 BSPP | P32KA12CP | | |
| 3/8 BSPP | P32KA13CP | | |
| 1/2 BSPP | P32KA14CP | | |
| 3/4 BSPP | P32KA16CP | | |



Angle Bracket

(Fits to regulator and filter/regulator bonnet)

P33KA00MR

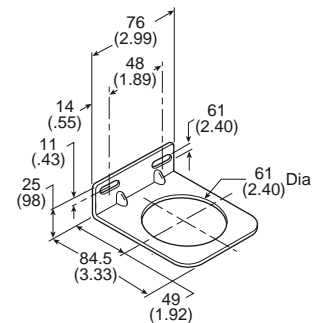

L-Bracket

(Fits to filter and lubricator body)

P33KA00ML

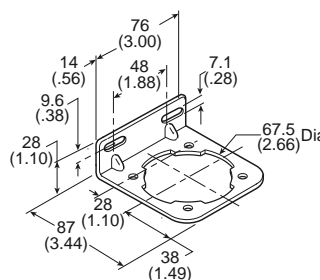

T-Bracket

(fits to body connector or port block)

P32KA00MB

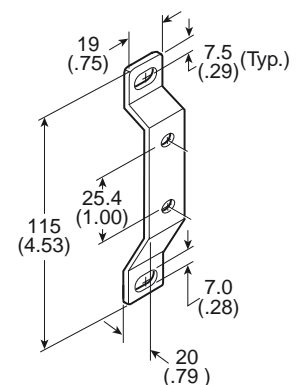









Global Air Preparation System

Kits

| Series | Description | Order Code | |
|-------------------|-------------------------------------|-------------------------------------------------|--|
| P31 P32 P33 | Panel Mount Nut (Plastic) | P31KA00MP P32KA00MP P33KA00MP | |
| P31 P32 P33 | Panel Mount Nut (Aluminum) | P31KA00MM P32KA00MM P33KA00MM | |
| P31 P32 P33 | 5µ Element Kit | P31KA00ESE P32KA00ESE P33KA00ESE | |
| P31 P32 P33 | 1µ Element Kit | P31KA00ES9 P32KA00ES9 P33KA00ES9 | |
| P31 P32 P33 | 0.01µ Element Kit | P31KA00ESC P32KA00ESC P33KA00ESC | |
| P31 P32 P33 | Adsorber Element Kit | P31KA00ESA P32KA00ESA P33KA00ESA | |
| P32 / P33 | Auto Drain Kit | P32KA00DA | |
| P32 / P33 | Differential Pressure Indicator Kit | P32KA00RQ | |
| P31 P32 / P33 | Fill Plug Kit | P31KA00PL P32KA00PL | |
| P31 / P32 / P33 | Drip Control Assembly Kit | P32KA00PG | |

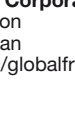

Global Air Preparation System

Kits

| Series | Description | Order Code | |
|-------------------|--------------------------------------------------|-------------------------------------------------------------|---------------------------------------------------------------------------------------|
| P31 P32 P33 | Plastic Bowl w/ Bowl Guard & Manual Drain | P31KA00BGM P32KA00BGM P33KA00BGM |  |
| P31 | Plastic Bowl w/ Bowl Guard & Pulse Drain | P31KA00BGB |  |
| P32 P33 | Plastic Bowl w/ Bowl Guard & Auto Drain | P32KA00BGA P33KA00BGA |  |
| P31 P32 P33 | Metal Bowl w/o Sight Gauge & Manual Drain | P31KA00BMM P32KA00BMM P33KA00BMM |  |
| P31 | Metal Bowl w/o Sight Gauge & Pulse Drain | P31KA00BMB |  |
| P32 P33 | Metal Bowl w/o Sight Gauge & Auto Drain | P32KA00BMA P33KA00BMA |  |
| P32 P33 | Metal Bowl w/ Sight Gauge & Manual Drain | P32KA00BSM P33KA00BSM |  |
| P32 P33 | Metal Bowl w/ Sight Gauge & Auto Drain | P32KA00BSA P33KA00BSA |  |
| P31 P32 P33 | Lubricator - Plastic Bowl w/ Bowl Guard No Drain | P31KA00BGN P32KA00BGN P33KA00BGN |  |
| P31 P32 P33 | Lubricator - Metal Bowl w/o Sight Gauge No Drain | P31KA00BMN P32KA00BMN P33KA00BMN |  |
| P32 P33 | Lubricator - Metal Bowl w/ Sight Gauge No Drain | P32KA00BSN P33KA00BSN | |

Global Air Preparation System

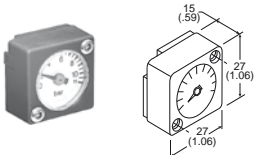
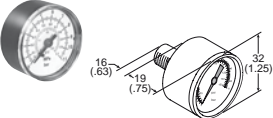
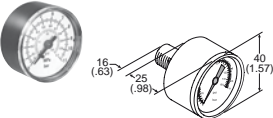
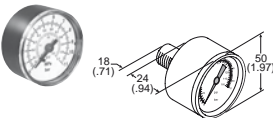
Kits

| Series | Description | Connection | Order Code | |
|-------------------|--------------------------------------------------------------|--------------------------------------------------------------------------------------------------------------------|--------------------------------------------------------------------------------------|---------------------------------------------------------------------------------------|
| P31 P32 P33 | Regulator - Relieving Repair Kit | | P31KA00RB P32KA00RB P33KA00RB | |
| P31 P32 P33 | Regulator - Non Relieving Repair Kit | | P31KA00RC P32KA00RC P33KA00RC | |
| P31 P32 P33 | Regulator - Main Adjusting Spring 0-2 bar (0-30 psig) Kit | | P31KA00PR P32KA00PR P33KA00PR | |
| P31 P32 P33 | Regulator - Main Adjusting Spring 0-4.1 bar (0-60 psig) Kit | | P31KA00PS P32KA00PS P33KA00PS | |
| P31 P32 P33 | Regulator - Main Adjusting Spring 0-8.6 bar (0-125 psig) Kit | | P31KA00PT P32KA00PT P33KA00PT | |
| P32 P33 | Regulator - Main Adjusting Spring 0-17 bar (0-250 psig) Kit | | P32KA00PV P33KA00PV | |
| P31 | Square Flush Mounting Gauge Kit | 0-4 bar 0-10 bar 0-60 psig 0-150 psig | K4511SCR04B K4511SCR11B K4511SCR060 K4511SCR150 |  |
| P31 | 1" Round Gauge | 0-60 psig / 0-4.1 bar 1/8" 0-160 psig / 0-10 bar 1/8" | K4510N18060 K4510N18160 |  |
| P31 | 40mm Round Gauge | 0-30 psig / 0-2 bar 1/8" 0-60 psig / 0-4.1 bar 1/8" 0-160 psig / 0-10 bar 1/8" | K4515N18030 K4515N18060 K4515N18160 |  |
| P32 / P33 | 50mm Round Gauge | 0-30 psig / 0-2 bar 1/4" 0-60 psig / 0-4.1 bar 1/4" 0-160 psig / 0-10 bar 1/4" 0-300 psig / 0-20 bar 1/4" | K4520N14030 K4520N14060 K4520N14160 K4520N14300 |  |
| P31 P32 / P33 | Body Connector O-ring (Spares kit) (Pack of 4) | | P31KA02CY P32KA04CY |  |

Global Air Preparation System

Safety Guide For Selecting And Using Pneumatic Division Products And Related Accessories

WARNING:

FAILURE OR IMPROPER SELECTION OR IMPROPER USE OF PNEUMATIC DIVISION PRODUCTS, ASSEMBLIES OR RELATED ITEMS (“PRODUCTS”) CAN CAUSE DEATH, PERSONAL INJURY, AND PROPERTY DAMAGE. POSSIBLE CONSEQUENCES OF FAILURE OR IMPROPER SELECTION OR IMPROPER USE OF THESE PRODUCTS INCLUDE BUT ARE NOT LIMITED TO:

- Unintended or mistimed cycling or motion of machine members or failure to cycle
- Work pieces or component parts being thrown off at high speeds.
- Failure of a device to function properly for example, failure to clamp or unclamp an associated item or device.
- Explosion
- Suddenly moving or falling objects.
- Release of toxic or otherwise injurious liquids or gasses.

Before selecting or using any of these Products, it is important that you read and follow the instructions below.

1. GENERAL INSTRUCTIONS

- 1.1. Scope: This safety guide is designed to cover general guidelines on the installation, use, and maintenance of Pneumatic Division Valves, FRLs (Filters, Pressure Regulators, and Lubricators), Vacuum products and related accessory components.
- 1.2. Fail-Safe: Valves, FRLs, Vacuum products and their related components can and do fail without warning for many reasons. Design all systems and equipment in a fail-safe mode, so that failure of associated valves, FRLs or Vacuum products will not endanger persons or property.
- 1.3. Relevant International Standards: For a good guide to the application of a broad spectrum of pneumatic fluid power devices see: ISO 4414:1998, Pneumatic Fluid Power – General Rules Relating to Systems. See www.iso.org for ordering information.
- 1.4. Distribution: Provide a copy of this safety guide to each person that is responsible for selection, installation, or use of Valves, FRLs or Vacuum products. Do not select, or use Parker valves, FRLs or vacuum products without thoroughly reading and understanding this safety guide as well as the specific Parker publications for the products considered or selected.
- 1.5. User Responsibility: Due to the wide variety of operating conditions and applications for valves, FRLs, and vacuum products Parker and its distributors do not represent or warrant that any particular valve, FRL or vacuum product is suitable for any specific end use system. This safety guide does not analyze all technical parameters that must be considered in selecting a product. The user, through its own analysis and testing, is solely responsible for:
 - Making the final selection of the appropriate valve, FRL, Vacuum component, or accessory.
 - Assuring that all user's performance, endurance, maintenance, safety, and warning requirements are met and that the application presents no health or safety hazards.
 - Complying with all existing warning labels and / or providing all appropriate health and safety warnings on the equipment on which the valves, FRLs or Vacuum products are used; and,
 - Assuring compliance with all applicable government and industry standards.
- 1.6. Safety Devices: Safety devices should not be removed, or defeated.
- 1.7. Warning Labels: Warning labels should not be removed, painted over or otherwise obscured.
- 1.8. Additional Questions: Call the appropriate Parker technical service department if you have any questions or require any additional information. See the Parker publication for the product being considered or used, or call 1-800-CPARKER, or go to www.parker.com, for telephone numbers of the appropriate technical service department.

2. PRODUCT SELECTION INSTRUCTIONS

- 2.1. Flow Rate: The flow rate requirements of a system are frequently the primary consideration when designing any pneumatic system. System components need to be able to provide adequate flow and pressure for the desired application.
- 2.2. Pressure Rating: Never exceed the rated pressure of a product. Consult product labeling, Pneumatic Division catalogs or the instruction sheets supplied for Maximum pressure ratings.
- 2.3. Temperature Rating: Never exceed the temperature rating of a product. Excessive heat can shorten the life expectancy of a product and result in complete product failure.
- 2.4. Environment: Many environmental conditions can affect the integrity and suitability of a product for a given application. Pneumatic Division products are designed for use in general purpose industrial applications. If these products are to be used in unusual circumstances such as direct sunlight and/or corrosive or caustic environments, such use can shorten the useful life and lead to premature failure of a product.
- 2.5. Lubrication and Compressor Carryover: Some modern synthetic oils can and will attack nitrile seals. If there is any possibility of synthetic oils or greases migrating into the pneumatic components check for compatibility with the seal materials used. Consult the factory or product literature for materials of construction.
- 2.6. Polycarbonate Bowls and Sight Gauges: To avoid potential polycarbonate bowl failures:
 - Do not locate polycarbonate bowls or sight gauges in areas where they could be subject to direct sunlight, impact blow, or temperatures outside of the rated range.
 - Do not expose or clean polycarbonate bowls with detergents, chlorinated hydro-carbons, ketones, esters or certain alcohols.
 - Do not use polycarbonate bowls or sight gauges in air systems where compressors are lubricated with fire resistant fluids such as phosphate ester and di-ester lubricants.

Global Air Preparation System

- 2.7. Chemical Compatibility: For more information on plastic component chemical compatibility see Pneumatic Division technical bulletins Tec-3, Tec-4, and Tec-5
- 2.8. Product Rupture: Product rupture can cause death, serious personal injury, and property damage.
- Do not connect pressure regulators or other Pneumatic Division products to bottled gas cylinders.
 - Do not exceed the Maximum primary pressure rating of any pressure regulator or any system component.
 - Consult product labeling or product literature for pressure rating limitations.
3. PRODUCT ASSEMBLY AND INSTALLATION INSTRUCTIONS
- 3.1. Component Inspection: Prior to assembly or installation a careful examination of the valves, FRLs or vacuum products must be performed. All components must be checked for correct style, size, and catalog number. DO NOT use any component that displays any signs of nonconformance.
- 3.2. Installation Instructions: Parker published Installation Instructions must be followed for installation of Parker valves, FRLs and vacuum components. These instructions are provided with every Parker valve or FRL sold, or by calling 1-800-CPARKER, or at www.parker.com.
- 3.3. Air Supply: The air supply or control medium supplied to Valves, FRLs and Vacuum components must be moisture-free if ambient temperature can drop below freezing
4. VALVE AND FRL MAINTENANCE AND REPLACEMENT INSTRUCTIONS
- 4.1. Maintenance: Even with proper selection and installation, valve, FRL and vacuum products service life may be significantly reduced without a continuing maintenance program. The severity of the application, risk potential from a component failure, and experience with any known failures in the application or in similar applications should determine the frequency of inspections and the servicing or replacement of Pneumatic Division products so that products are replaced before any failure occurs. A maintenance program must be established and followed by the user and, at Minimum, must include instructions 4.2 through 4.10.
- 4.2. Installation and Service Instructions: Before attempting to service or replace any worn or damaged parts consult the appropriate Service Bulletin for the valve or FRL in question for the appropriate practices to service the unit in question. These Service and Installation Instructions are provided with every Parker valve and FRL sold, or are available by calling 1-800-CPARKER, or by accessing the Parker web site at www.parker.com.
- 4.3. Lockout / Tagout Procedures: Be sure to follow all required lockout and tagout procedures when servicing equipment. For more information see: OSHA Standard – 29 CFR, Part 1910.147, Appendix A, The Control of Hazardous Energy – (Lockout / Tagout)
- 4.4. Visual Inspection: Any of the following conditions requires immediate system shut down and replacement of worn or damaged components:
- Air leakage: Look and listen to see if there are any signs of visual damage to any of the components in the system. Leakage is an indication of worn or damaged components.
 - Damaged or degraded components: Look to see if there are any visible signs of wear or component degradation.
 - Kinked, crushed, or damaged hoses. Kinked hoses can result in restricted air flow and lead to unpredictable system behavior.
 - Any observed improper system or component function: Immediately shut down the system and correct malfunction.
 - Excessive dirt build-up: Dirt and clutter can mask potentially hazardous situations.
- Caution: Leak detection solutions should be rinsed off after use.
- 4.5. Routine Maintenance Issues:
- Remove excessive dirt, grime and clutter from work areas.
 - Make sure all required guards and shields are in place.
- 4.6. Functional Test: Before initiating automatic operation, operate the system manually to make sure all required functions operate properly and safely.
- 4.7. Service or Replacement Intervals: It is the user's responsibility to establish appropriate service intervals. Valves, FRLs and vacuum products contain components that age, harden, wear, and otherwise deteriorate over time. Environmental conditions can significantly accelerate this process. Valves, FRLs and vacuum components need to be serviced or replaced on routine intervals. Service intervals need to be established based on:
- Previous performance experiences.
 - Government and / or industrial standards.
 - When failures could result in unacceptable down time, equipment damage or personal injury risk.
- 4.8. Servicing or Replacing of any Worn or Damaged Parts: To avoid unpredictable system behavior that can cause death, personal injury and property damage:
- Follow all government, state and local safety and servicing practices prior to service including but not limited to all OSHA Lockout Tagout procedures (OSHA Standard – 29 CFR, Part 1910.147, Appendix A, The Control of Hazardous Energy – Lockout / Tagout).
 - Disconnect electrical supply (when necessary) before installation, servicing, or conversion.
 - Disconnect air supply and depressurize all air lines connected to system and Pneumatic Division products before installation, service, or conversion.
 - Installation, servicing, and / or conversion of these products must be performed by knowledgeable personnel who understand how pneumatic products are to be applied.
 - After installation, servicing, or conversions air and electrical supplies (when necessary) should be connected and the product tested for proper function and leakage. If audible leakage is present, or if the product does not operate properly, do not put product or system into use.
 - Warnings and specifications on the product should not be covered or painted over. If masking is not possible, contact your local representative for replacement labels.
- 4.9. Putting Serviced System Back into Operation: Follow the guidelines above and all relevant Installation and Maintenance Instructions supplied with the valve FRL or vacuum component to insure proper function of the system.

The items described in this document and other documents and descriptions provided by Parker Hannifin Corporation, its subsidiaries and its authorized distributors ("Seller") are hereby offered for sale at prices to be established by Seller. This offer and its acceptance by any customer ("Buyer") shall be governed by all of the following Terms and Conditions. Buyer's order for any item described in its document, when communicated to Seller verbally, or in writing, shall constitute acceptance of this offer. All goods or work described will be referred to as "Products".

1. Terms and Conditions. Seller's willingness to offer Products, or accept an order for Products, to or from Buyer is expressly conditioned on Buyer's assent to these Terms and Conditions and to the terms and conditions found on-line at www.parker.com/saleterms/. Seller objects to any contrary or additional term or condition of Buyer's order or any other document issued by Buyer.

2. Price Adjustments; Payments. Prices stated on the reverse side or preceding pages of this document are valid for 30 days. After 30 days, Seller may change prices to reflect any increase in its costs resulting from state, federal or local legislation, price increases from its suppliers, or any change in the rate, charge, or classification of any carrier. The prices stated on the reverse or preceding pages of this document do not include any sales, use, or other taxes unless so stated specifically. Unless otherwise specified by Seller, all prices are F.O.B. Seller's facility, and payment is due 30 days from the date of invoice. After 30 days, Buyer shall pay interest on any unpaid invoices at the rate of 1.5% per month or the maximum allowable rate under applicable law.

3. Delivery Dates; Title and Risk; Shipment. All delivery dates are approximate and Seller shall not be responsible for any damages resulting from any delay. Regardless of the manner of shipment, title to any products and risk of loss or damage shall pass to Buyer upon tender to the carrier at Seller's facility (i.e., when it's on the truck, it's yours). Unless otherwise stated, Seller may exercise its judgment in choosing the carrier and means of delivery. No deferral of shipment at Buyers' request beyond the respective dates indicated will be made except on terms that will indemnify, defend and hold Seller harmless against all loss and additional expense. Buyer shall be responsible for any additional shipping charges incurred by Seller due to Buyer's changes in shipping, product specifications or in accordance with Section 13, herein.

4. Warranty. Seller warrants that the Products sold hereunder shall be free from defects in material or workmanship for a period of twelve months from the date of delivery to Buyer or 2,000 hours of normal use, whichever occurs first. This warranty is made only to Buyer and does not extend to anyone to whom Products are sold after purchased from Seller. The prices charged for Seller's products are based upon the exclusive limited warranty stated above, and upon the following disclaimer: **DISCLAIMER OF WARRANTY: THIS WARRANTY COMPRISES THE SOLE AND ENTIRE WARRANTY PERTAINING TO PRODUCTS PROVIDED HEREUNDER. SELLER DISCLAIMS ALL OTHER WARRANTIES, EXPRESS AND IMPLIED, INCLUDING MERCHANTABILITY AND FITNESS FOR A PARTICULAR PURPOSE.**

5. Claims; Commencement of Actions. Buyer shall promptly inspect all Products upon delivery. No claims for shortages will be allowed unless reported to the Seller within 10 days of delivery. No other claims against Seller will be allowed unless asserted in writing within 60 days after delivery or, in the case of an alleged breach of warranty, within 30 days after the date within the warranty period on which the defect is or should have been discovered by Buyer. Any action based upon breach of this agreement or upon any other claim arising out of this sale (other than an action by Seller for any amount due to Seller from Buyer) must be commenced within thirteen months from the date of tender of delivery by Seller or, for a cause of action based upon an alleged breach of warranty, within thirteen months from the date within the warranty period on which the defect is or should have been discovered by Buyer.

6. LIMITATION OF LIABILITY. UPON NOTIFICATION, SELLER WILL, AT ITS OPTION, REPAIR OR REPLACE A DEFECTIVE PRODUCT, OR REFUND THE PURCHASE PRICE. **IN NO EVENT SHALL SELLER BE LIABLE TO BUYER FOR ANY SPECIAL, INDIRECT, INCIDENTAL OR CONSEQUENTIAL DAMAGES ARISING OUT OF, OR AS THE RESULT OF, THE SALE, DELIVERY, NON-DELIVERY, SERVICING, USE OR LOSS OF USE OF THE PRODUCTS OR ANY PART THEREOF, OR FOR ANY CHARGES OR EXPENSES OF ANY NATURE INCURRED WITHOUT SELLER'S WRITTEN CONSENT, EVEN IF SELLER HAS BEEN NEGLIGENT, WHETHER IN CONTRACT, TORT OR OTHER LEGAL THEORY. IN NO EVENT SHALL SELLER'S LIABILITY UNDER ANY CLAIM MADE BY BUYER EXCEED THE PURCHASE PRICE OF THE PRODUCTS.**

7. Contingencies. Seller shall not be liable for any default or delay in performance if caused by circumstances beyond the reasonable control of Seller.

8. User Responsibility. The user, through its own analysis and testing, is solely responsible for making the final selection of the system and Product and assuring that all performance, endurance, maintenance, safety and warning requirements of the application are met. The user must analyze all aspects of the application and follow applicable industry standards and Product information. If Seller provides Product or system options, the user is responsible for determining that such data and specifications are suitable and sufficient for all applications and reasonably foreseeable uses of the Products or systems.

9. Loss to Buyer's Property. Any designs, tools, patterns, materials, drawings, confidential information or equipment furnished by Buyer or any other items which become Buyer's property, may be considered obsolete and may be destroyed by Seller after two consecutive years have elapsed without Buyer placing an order for the items which are manufactured using such property. Seller shall not be responsible for any loss or damage to such property while it is in Seller's possession or control.

10. Special Tooling. A tooling charge may be imposed for any special tooling, including without limitation, dies, fixtures, molds and patterns, acquired to manufacture Products. Such special tooling shall be and remain Seller's property notwithstanding payment of any charges by Buyer. In no event will Buyer acquire any interest in apparatus belonging to Seller which is utilized in the manufacture of the Products, even if such apparatus has been specially converted or adapted for such manufacture and notwithstanding any charges paid by Buyer. Unless otherwise agreed, Seller shall have the right to alter, discard or otherwise dispose of any special tooling or other property in its sole discretion at any time.

11. Buyer's Obligation; Rights of Seller. To secure payment of all sums due or otherwise, Seller shall retain a security interest in the goods delivered and this agreement shall be deemed a Security Agreement under the Uniform Commercial Code. Buyer authorizes Seller as its attorney to execute and file on Buyer's behalf all documents Seller deems necessary to perfect its security interest. Seller shall have a security interest in, and lien upon, any property of Buyer in Seller's possession as security for the payment of any amounts owed to Seller by Buyer.

12. Improper use and Indemnity. Buyer shall indemnify, defend, and hold Seller harmless from any claim, liability, damages, lawsuits, and costs (including attorney fees), whether for personal injury, property damage, patent, trademark or copyright infringement or any other claim, brought by or incurred by Buyer, Buyer's employees, or any other person, arising out of: (a) improper selection, improper application or other misuse of Products purchased by Buyer from Seller; (b) any act or omission, negligent or otherwise, of Buyer; (c) Seller's use of patterns, plans, drawings, or specifications furnished by Buyer to manufacture Product; or (d) Buyer's failure to comply with these terms and conditions. Seller shall not indemnify Buyer under any circumstance except as otherwise provided.

13. Cancellations and Changes. Orders shall not be subject to cancellation or change by Buyer for any reason, except with Seller's written consent and upon terms that will indemnify, defend and hold Seller harmless against all direct, incidental and consequential loss or damage. Seller may change product features, specifications, designs and availability with notice to Buyer.

14. Limitation on Assignment. Buyer may not assign its rights or obligations under this agreement without the prior written consent of Seller.

15. Entire Agreement. This agreement contains the entire agreement between the Buyer and Seller and constitutes the final, complete and exclusive expression of the terms of the agreement. All prior or contemporaneous written or oral agreements or negotiations with respect to the subject matter are herein merged.

16. Waiver and Severability. Failure to enforce any provision of this agreement will not waive that provision nor will any such failure prejudice Seller's right to enforce that provision in the future. Invalidation of any provision of this agreement by legislation or other rule of law shall not invalidate any other provision herein. The remaining provisions of this agreement will remain in full force and effect.

17. Termination. This agreement may be terminated by Seller for any reason and at any time by giving Buyer thirty (30) days written notice of termination. In addition, Seller may by written notice immediately terminate this agreement for the following: (a) Buyer commits a breach of any provision of this agreement (b) the appointment of a trustee, receiver or custodian for all or any part of Buyer's property (b) the filing of a petition for relief in bankruptcy of the other Party on its own behalf, or by a third party (c) an assignment for the benefit of creditors, or (d) the dissolution or liquidation of the Buyer.

18. Governing Law. This agreement and the sale and delivery of all Products hereunder shall be deemed to have taken place in and shall be governed and construed in accordance with the laws of the State of Ohio, as applicable to contracts executed and wholly performed therein and without regard to conflicts of laws principles. Buyer irrevocably agrees and consents to the exclusive jurisdiction and venue of the courts of Cuyahoga County, Ohio with respect to any dispute, controversy or claim arising out of or relating to this agreement. Disputes between the parties shall not be settled by arbitration unless, after a dispute has arisen, both parties expressly agree in writing to arbitrate the dispute.

19. Indemnity for Infringement of Intellectual Property Rights. Seller shall have no liability for infringement of any patents, trademarks, copyrights, trade dress, trade secrets or similar rights except as provided in this Section. Seller will defend and indemnify Buyer against allegations of infringement of U.S. patents, U.S. trademarks, copyrights, trade dress and trade secrets ("Intellectual Property Rights"). Seller will defend at its expense and will pay the cost of any settlement or damages awarded in an action brought against Buyer based on an allegation that a Product sold pursuant to this Agreement infringes the Intellectual Property Rights of a third party. Seller's obligation to defend and indemnify Buyer is contingent on Buyer notifying Seller within ten (10) days after Buyer becomes aware of such allegations of infringement, and Seller having sole control over the defense of any allegations or actions including all negotiations for settlement or compromise. If a Product is subject to a claim that it infringes the Intellectual Property Rights of a third party, Seller may, at its sole expense and option, procure for Buyer the right to continue using the Product, replace or modify the Product so as to make it noninfringing, or offer to accept return of the Product and return the purchase price less a reasonable allowance for depreciation. Notwithstanding the foregoing, Seller shall have no liability for claims of infringement based on information provided by Buyer, or directed to Products delivered hereunder for which the designs are specified in whole or part by Buyer, or infringements resulting from the modification, combination or use in a system of any Product sold hereunder. The foregoing provisions of this Section shall constitute Seller's sole and exclusive liability and Buyer's sole and exclusive remedy for infringement of Intellectual Property Rights.

20. Taxes. Unless otherwise indicated, all prices and charges are exclusive of excise, sales, use, property, occupational or like taxes which may be imposed by any taxing authority upon the manufacture, sale or delivery of Products.

21. Equal Opportunity Clause. For the performance of government contracts and where dollar value of the Products exceed \$10,000, the equal employment opportunity clauses in Executive Order 11246, VEVRAA, and 41 C.F.R. §§ 60-1.4(a), 60-741.5(a), and 60-250.4, are hereby incorporated.

Parker Worldwide

AE – UAE, Dubai
Tel: +971 4 8127100
parker.me@parker.com

AR – Argentina, Buenos Aires
Tel: +54 3327 44 4129

AT – Austria, Wiener Neustadt
Tel: +43 (0)2622 23501-0
parker.austria@parker.com

AT – Eastern Europe, Wiener Neustadt
Tel: +43 (0)2622 23501 900
parker.easteurope@parker.com

AU – Australia, Castle Hill
Tel: +61 (0)2-9634 7777

AZ – Azerbaijan, Baku
Tel: +994 50 2233 458
parker.azerbaijan@parker.com

BE/LU – Belgium, Nivelles
Tel: +32 (0)67 280 900
parker.belgium@parker.com

BR – Brazil, Cachoeirinha RS
Tel: +55 51 3470 9144

BY – Belarus, Minsk
Tel: +375 17 209 9399
parker.belarus@parker.com

CA – Canada, Milton, Ontario
Tel: +1 905 693 3000

CH – Switzerland, Etoy
Tel: +41 (0) 21 821 02 30
parker.switzerland@parker.com

CL – Chile, Santiago
Tel: +56 2 623 1216

CN – China, Shanghai
Tel: +86 21 2899 5000

CZ – Czech Republic, Klecany
Tel: +420 284 083 111
parker.czechrepublic@parker.com

DE – Germany, Kaarst
Tel: +49 (0)2131 4016 0
parker.germany@parker.com

DK – Denmark, Ballerup
Tel: +45 43 56 04 00
parker.denmark@parker.com

ES – Spain, Madrid
Tel: +34 902 330 001
parker.spain@parker.com

FI – Finland, Vantaa
Tel: +358 (0)20 753 2500
parker.finland@parker.com

FR – France, Contamine s/Arve
Tel: +33 (0)4 50 25 80 25
parker.france@parker.com

GR – Greece, Athens
Tel: +30 210 933 6450
parker.greece@parker.com

HK – Hong Kong
Tel: +852 2428 8008

HU – Hungary, Budapest
Tel: +36 1 220 4155
parker.hungary@parker.com

IE – Ireland, Dublin
Tel: +353 (0)1 466 6370
parker.ireland@parker.com

IN – India, Mumbai
Tel: +91 22 6513 7081-85

IT – Italy, Corsico (MI)
Tel: +39 02 45 19 21
parker.italy@parker.com

JP – Japan, Tokyo
Tel: +(81) 3 6408 3901

KR – South Korea, Seoul
Tel: +82 2 559 0400

KZ – Kazakhstan, Almaty
Tel: +7 7272 505 800
parker.easteurope@parker.com

LV – Latvia, Riga
Tel: +371 6 745 2601
parker.latvia@parker.com

MX – Mexico, Apodaca
Tel: +52 81 8156 6000

MY – Malaysia, Shah Alam
Tel: +60 3 7849 0800

NL – The Netherlands, Oldenzaal
Tel: +31 (0)541 585 000
parker.nl@parker.com

NO – Norway, Ski
Tel: +47 64 91 10 00
parker.norway@parker.com

NZ – New Zealand, Mt Wellington
Tel: +64 9 574 1744

PL – Poland, Warsaw
Tel: +48 (0)22 573 24 00
parker.poland@parker.com

PT – Portugal, Leca da Palmeira
Tel: +351 22 999 7360
parker.portugal@parker.com

RO – Romania, Bucharest
Tel: +40 21 252 1382
parker.romania@parker.com

RU – Russia, Moscow
Tel: +7 495 645-2156
parker.russia@parker.com

SE – Sweden, Spånga
Tel: +46 (0)8 59 79 50 00
parker.sweden@parker.com

SG – Singapore
Tel: +65 6887 6300

SK – Slovakia, Banská Bystrica
Tel: +421 484 162 252
parker.slovakia@parker.com

SL – Slovenia, Novo Mesto
Tel: +386 7 337 6650
parker.slovenia@parker.com

TH – Thailand, Bangkok
Tel: +662 717 8140

TR – Turkey, Istanbul
Tel: +90 216 4997081
parker.turkey@parker.com

TW – Taiwan, Taipei
Tel: +886 2 2298 8987

UA – Ukraine, Kiev
Tel: +380 44 494 2731
parker.ukraine@parker.com

UK – United Kingdom, Warwick
Tel: +44 (0)1926 317 878
parker.uk@parker.com

US – USA, Cleveland
Tel: +1 216 896 3000

VE – Venezuela, Caracas
Tel: +58 212 238 5422

ZA – South Africa, Kempton Park
Tel: +27 (0)11 961 0700
parker.southafrica@parker.com

Catalog 0750-2 US. November, 2010

© 2010 Parker Hannifin Corporation. All rights reserved.



Parker Hannifin Corporation
Pneumatic Division
8676 E. M89
P.O. Box 901
Richland, MI 49083 USA
Tel: 269 629 5000
Fax: 269 629 5385



**PRZEDSTAWICIEL
HANDLOWY**

"ARMMASTER"

Przedsiębiorstwo Handlowo-Usługowe
Stanisław Zawieja
98-200 Sieradz; ul. E. Orzeszkowej 3
NIP: 827-108-05-12

Biuro handlowe

98-200 Sieradz; ul. Jana Pawła 11 59
Tel. / fax (43) 822 32 36
Tel. kom. 602 373 675
www.armmaster.com.pl