



aerospace  
 climate control  
 electromechanical  
 filtration  
 fluid & gas handling  
 hydraulics  
**pneumatics**  
 process control  
 sealing & shielding



# Pneumatic Linear Compact Cylinders, P1Q Series

Ø12mm - 100mm bore size

Catalogue PDE2663TCUK November 2012

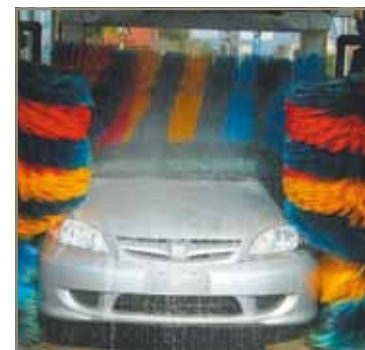

ENGINEERING YOUR SUCCESS



PRZEDSTAWICIEL  
 HANDLOWY

"ARMMASTER"

Przedsiębiorstwo Handlowo-Usługowe  
 Stanisław Zawieja  
 98-200 Sieradz; ul. E. Orzeszkowej 3  
 NIP: 827-108-05-12

Biurowisko

98-200 Sieradz; ul. Jana Pawła || 59  
 Tel. / fax (43) 822 32 36  
 Tel. kom. 602 373 675  
 www.armmaster.com.pl

Features ..... 3

Technical Information

- Main data ..... 4
- Material specification ..... 4
- Working medium, air quality..... 4
- Cylinder forces ..... 5
- Front profiles by bore size..... 5

Application Guide ..... 6

Dimensions

- Non-magnetic ..... 7
- Magnetic ..... 8

Order code key..... 9

Part numbers - Double acting / Non magnetic ..... 10

Part numbers - Double acting / Magnetic ..... 11

Mountings

- Flange ..... 12
- Foot ..... 12
- Clevis ..... 13
- Lock nut..... 14

Accessories

- Sensors..... 15-17

**⚠ WARNING**

FAILURE OR IMPROPER SELECTION OR IMPROPER USE OF THE PRODUCTS AND/OR SYSTEMS DESCRIBED HEREIN OR RELATED ITEMS CAN CAUSE DEATH, PERSONAL INJURY AND PROPERTY DAMAGE.

This document and other information from Parker Hannifin Corporation, its subsidiaries and authorized distributors provide product and/or system options for further investigation by users having technical expertise. It is important that you analyze all aspects of your application including consequences of any failure, and review the information concerning the product or system in the current product catalog. Due to the variety of operating conditions and applications for these products or systems, the user, through its own analysis and testing, is solely responsible for making the final selection of the products and systems and assuring that all performance, safety and warning requirements of the application are met.

The products described herein, including without limitation, product features, specifications, designs, availability and pricing, are subject to change by Parker Hannifin Corporation and its subsidiaries at any time without notice.

**Offer of Sale**

The items described in this document are hereby offered for sale by Parker Hannifin Corporation, its subsidiaries or its authorized distributors. This offer and its acceptance are governed by the provisions stated on the separate page of this document entitled "Offer of Sale".

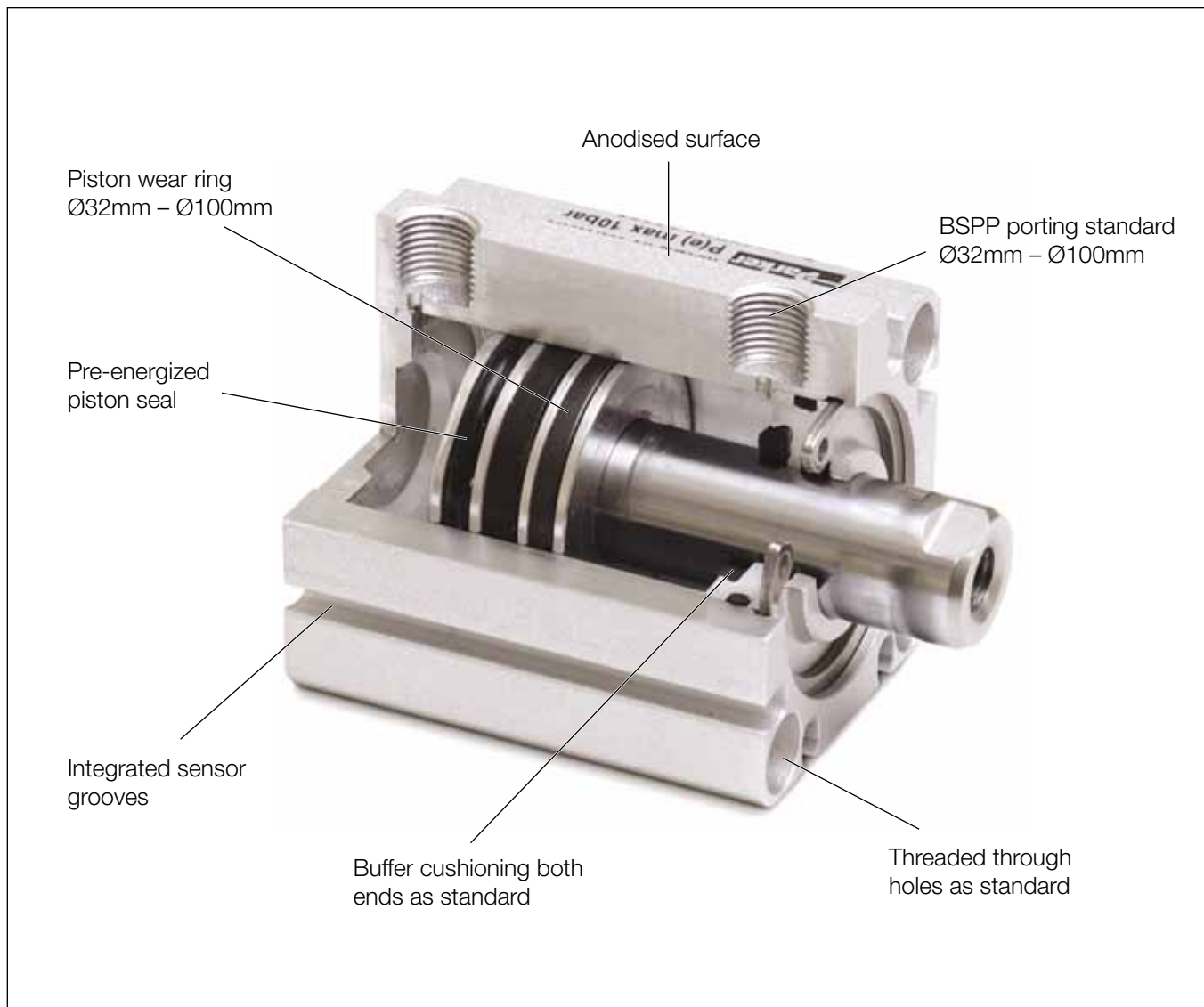

### **P1Q Compact Cylinder**

Parker's P1Q series cylinders provide an economical, compact design suited for a variety of applications. With its modular flexibility, the P1Q will provide the ideal solution machine builders need today.

The P1Q series is available in 10 bore sizes from 12 mm to 100 mm and standard strokes from 5 mm to 100 mm. The cylinder is supplied in a choice of magnetic or non-magnetic function, the non-magnetic version offers very short axial dimensions. For optimum compactness the P1Q range is supplied with female piston rod thread.

The P1Q provides quieter operation due to its built in buffer cushioning which is standard on all bore sizes. Included within the magnetic versions bores 32 - 100mm is a teflon piston wear ring providing superior life.

### **Sensors and Accessories**

When position signals are needed anywhere along the stroke the integrated sensor grooves provide flexible mounting of any combination of PNP, NPN, reed sensors with flying leads and M8 cord options within the Parker P8S Global Sensor Family.

In addition to the compactness and modular design flexibility of P1Q are a range of cylinder mountings including flange, foot and clevis brackets to ease installation.

**General technical data**

Product type	Compact	
Bore size	12 - 100 mm	
Stroke length	100 mm	
Versions	P1Q...B	Double acting, Non magnetic
	P1Q...G	Double acting, Magnetic
Cushioning	Elastic cushioning	
Position sensing	Proximity sensor	
Installation	Direct	Through holes
	Accessories	Cylinder mountings
Mounting position	Any	

**Operating and environmental data**

Operating medium	For best possible service life and trouble-free operation it is recommended to use dry, filtered compressed air to ISO 8573-1:2010 quality class 3.4.3. This specifies a dew point of +3°C for indoor operation (a lower dew point should be selected for outdoor operation) and is in line with the air quality from most standard compressors with a standard filter. Refer to page 22.
Operating pressure	0.5 bar to 10 bar
Ambient temperature	-5°C to +60°C
Pre-lubricated	Further lubrication is normally not necessary. If additional lubrication is introduced it must be continued.
Corrosion resistance	High resistance to corrosion and chemicals. Materials and surface treatment have been selected for industrial applications where solvents and detergents are frequently used.

**Material specification**

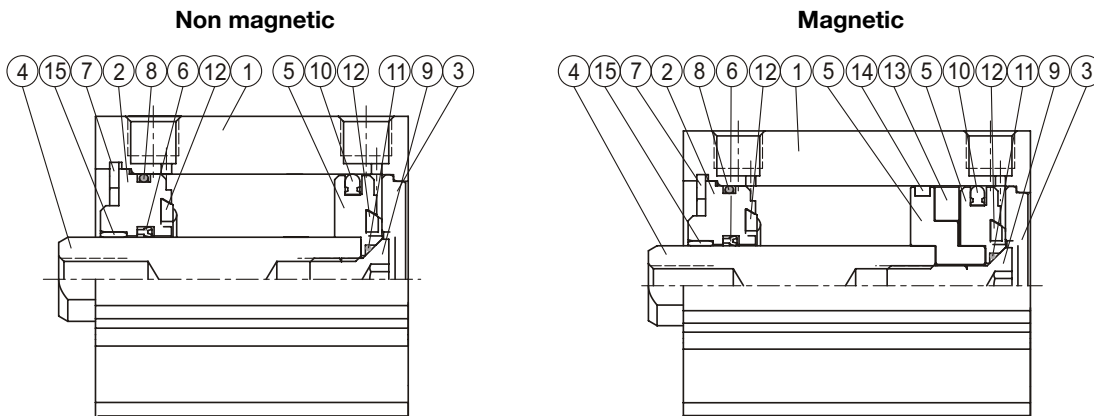

No	Part name / bore	12 - 25	32	40 - 100
1	Body	Hard anodised aluminium alloy		
2	Front cover	Hard anodised aluminium alloy	Anodised aluminium alloy	
3	Rear cover	Anodised aluminium alloy		
4	Piston rod	Stainless steel		Medium carbon steel
5	Piston	Anodised aluminium alloy		
6	Piston rod seal	NBR		
7	Circlip	Stainless steel	Spring steel	
8	O ring	NBR		
9	Piston bolt	Stainless steel	SCM	
10	Piston seal	NBR		
11	Piston gasket	NBR		
12	Buffer	NBR		
13	Magnet	Plastic		
14	Wear ring	-	Teflon	
15	Bush	-	-	Bearing alloy

Main data: P1Q

Cylinder designation	Cylinder bore		Piston rod area		Thread (female)	Thread (male)	Total weight		Air consumption litres	Port size
	mm	cm <sup>2</sup>	mm	cm <sup>2</sup>			at 0 mm stroke	addition per 5 mm stroke		
P1Q012	12	1.1	6	0.28	M3 x 0.5	M5 x 0.8	0.06	0.01	0.0139 <sup>1)</sup>	M5
P1Q016	16	2.0	8	0.50	M4 x 0.7	M6 x 1.0	0.07	0.02	0.0246 <sup>1)</sup>	M5
P1Q020	20	3.1	10	0.79	M5 x 0.8	M8 x 1.25	0.09	0.03	0.0385 <sup>1)</sup>	M5
P1Q025	25	4.9	12	1.1	M6 x 1.0	M10 x 1.25	0.13	0.03	0.0633 <sup>1)</sup>	M5
P1Q032	32	8.0	16	2.0	M8 x 1.25	M14 x 1.5	0.19	0.03	0.1050 <sup>1)</sup>	G1/8
P1Q040	40	12.6	16	2.0	M8 x 1.25	M14 x 1.5	0.25	0.03	0.1620 <sup>1)</sup>	G1/8
P1Q050	50	19.6	20	3.1	M10 x 1.5	M18 x 1.5	0.45	0.04	0.2530 <sup>1)</sup>	G1/4
P1Q063	63	31.2	20	3.1	M10 x 1.5	M18 x 1.5	0.68	0.05	0.4140 <sup>1)</sup>	G1/4
P1Q080	80	50.3	25	4.9	M16 x 2.0	M22 x 1.5	1.25	0.07	0.6690 <sup>1)</sup>	G3/8
P1Q100	100	78.5	30	7.0	M20 x 2.5	M26 x 1.5	1.93	0.15	1.0430 <sup>1)</sup>	G3/8

<sup>1)</sup> Free air consumption per 10 mm stroke length for a double stroke at 6 bar

Cylinder forces, double acting variants

Cyl. bore/ pist. rod mm	Stroke	Piston area cm <sup>2</sup>	Max theoretical force in N (bar)									
			1.0	2.0	3.0	4.0	5.0	6.0	7.0	8.0	9.0	10.0
12/6	+	1.1	11	23	34	45	57	<b>68</b>	79	90	102	113
	-	0.8	8	17	25	34	42	<b>51</b>	59	68	76	85
16/8	+	2.0	20	40	60	80	101	<b>121</b>	141	161	181	201
	-	1.5	15	30	45	60	75	<b>90</b>	106	121	136	151
20/10	+	3.1	31	63	94	126	157	<b>188</b>	220	251	283	314
	-	2.4	24	47	71	94	118	<b>141</b>	165	188	212	236
25/12	+	4.9	49	98	147	196	245	<b>295</b>	344	393	442	491
	-	3.8	38	76	113	151	189	<b>227</b>	264	302	340	378
32/16	+	8.0	80	161	241	322	402	<b>483</b>	563	643	724	804
	-	6.0	60	121	181	241	302	<b>362</b>	422	483	543	603
40/16	+	12.6	126	251	377	503	628	<b>754</b>	880	1005	1131	1257
	-	10.6	106	211	317	422	528	<b>633</b>	739	844	950	1056
50/20	+	19.6	196	393	589	785	982	<b>1178</b>	1374	1571	1767	1963
	-	16.5	165	330	495	660	825	<b>990</b>	1155	1319	1484	1649
63/20	+	31.2	312	623	935	1247	1559	<b>1870</b>	2182	2494	2806	3117
	-	28.0	280	561	841	1121	1402	<b>1682</b>	1962	2242	2523	2803
80/25	+	50.3	503	1005	1508	2011	2513	<b>3016</b>	3519	4021	4524	5027
	-	45.4	454	907	1361	1814	2268	<b>2721</b>	3175	3629	4082	4536
100/30	+	78.5	785	1571	2356	3142	3927	<b>4712</b>	5498	6283	7069	7854
	-	71.5	715	1430	2145	2860	3575	<b>4290</b>	5005	5720	6435	7150

+ = Outward stroke  
- = Return stroke

Note:

Select a theoretical force 50-100% larger than the force required

Front profiles by bore size

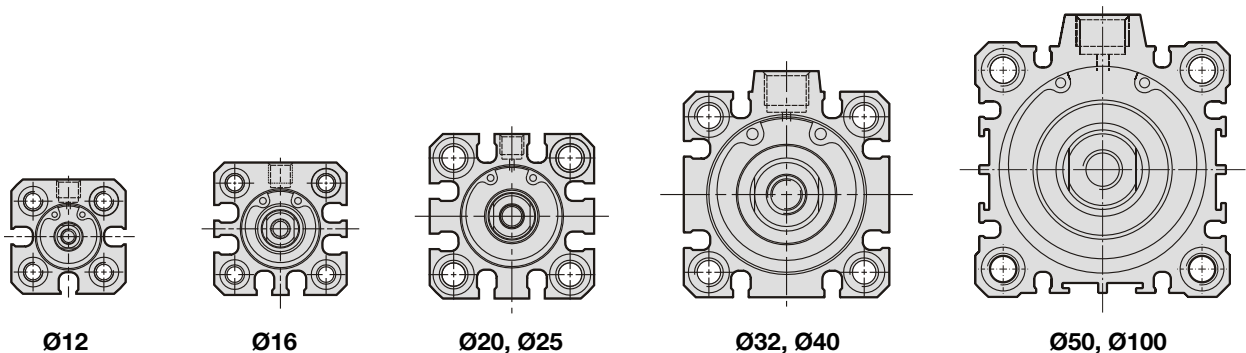

**Selecting Pneumatic System Components**

**Cylinder to Valve:** The below chart contains recommendations for selecting air valve products based on 5.5 bar with a 0.35 bar pressure drop. The values within the chart show the corresponding Cv values.

**Moduflex Valve System**

- Stand-alone valves, short-build valve manifold, or large valve manifold configurations available
- Cv range from 0.18 – 0.80
- Peripheral modules available— flow control, pressure regulation, P.O. check valves and vacuum generators



Cylinder speed (mm/s)	Cylinder bore size									
	12	16	20	25	32	40	50	63	80	100
50	0.004	0.01	0.01	0.02	0.03	0.04	0.06	0.10	0.16	0.26
100	0.01	0.01	0.02	0.03	0.05	0.08	0.13	0.20	0.33	0.51
150	0.01	0.02	0.03	0.05	0.08	0.12	0.19	0.30	0.49	0.77
200	0.01	0.03	0.04	0.06	0.10	0.16	0.26	0.41	0.65	1.02
250	0.02	0.03	0.05	0.08	0.13	0.20	0.32	0.51	0.82	1.28
300	0.02	0.04	0.06	0.10	0.16	0.25	0.38	0.61	0.98	1.53
350	0.03	0.05	0.07	0.11	0.18	0.29	0.45	0.71	1.15	1.79
400	0.03	0.05	0.08	0.13	0.21	0.33	0.51	0.81	1.31	2.04
450	0.03	0.06	0.09	0.14	0.24	0.37	0.58	0.91	1.47	2.30
500	0.04	0.07	0.10	0.16	0.26	0.41	0.64	1.01	1.64	2.56
	Size 1					Size 2			See Larger valve system	

**Isys Micro / ISO Valve System**

- Isys Micro Cv range 0.30 – 0.35
- IsysNet system fieldbus, Turck system fieldbus, 25 pin D-sub, or low cost Moduflex fieldbus options available
- Isys ISO offers 5 sizes with Cv range 0.55 – 6.0



Cylinder speed (mm/s)	Cylinder bore size										Valve range
	12	16	20	25	32	40	50	63	80	100	
50	0.004	0.01	0.01	0.02	0.03	0.04	0.06	0.10	0.16	0.26	Isys Micro
100	0.01	0.01	0.02	0.03	0.05	0.08	0.13	0.20	0.33	0.51	
150	0.01	0.02	0.03	0.05	0.08	0.12	0.19	0.30	0.49	0.77	HA
200	0.01	0.03	0.04	0.06	0.10	0.16	0.26	0.41	0.65	1.02	
250	0.02	0.03	0.05	0.08	0.13	0.20	0.32	0.51	0.82	1.28	H2
300	0.02	0.04	0.06	0.10	0.16	0.25	0.38	0.61	0.98	1.53	
350	0.03	0.05	0.07	0.11	0.18	0.29	0.45	0.71	1.15	1.79	
400	0.03	0.05	0.08	0.13	0.21	0.33	0.51	0.81	1.31	2.04	
450	0.03	0.06	0.09	0.14	0.24	0.37	0.58	0.91	1.47	2.30	
500	0.04	0.07	0.10	0.16	0.26	0.41	0.64	1.01	1.64	2.56	

**Non-magnetic Dimensions**

**Ø12 - Ø16**

**Ø20 - Ø25**

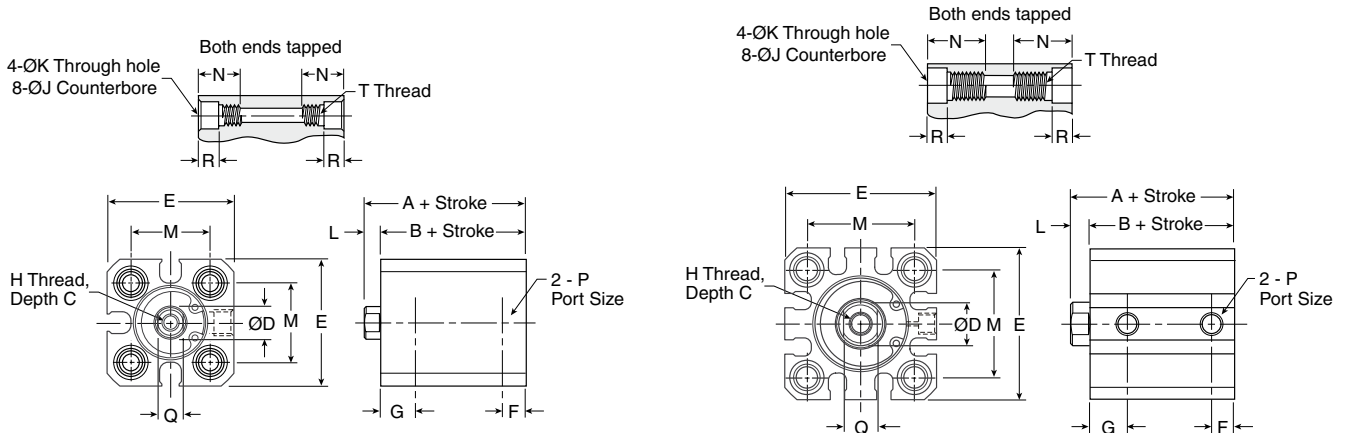

**Ø32 - Ø100**

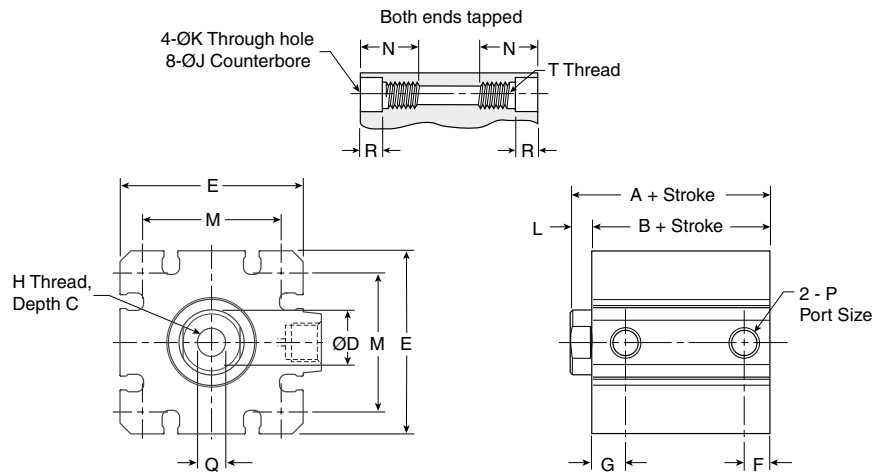

**Dimensions**

Bore size	A		B		C	D	E	F	G	H	J	K	L	M	N	P	Q	R	T
	5 to 50mm	75 to 100mm	5 to 50mm	75 to 100mm															
12	20.5	-	17	-	6	6	25	5	7.5	M3x0.5	6.5	3.5	3.5	15.5	11	M5x0.8	5	4	M4x0.7
16	20.5	-	17	-	8	8	29	5	7.5	M4x0.7	6.5	3.5	3.5	20	11	M5x0.8	6	4	M4x0.7
20	24	-	19.5	-	7	10	36	5.5	9	M5x0.8	9	5.4	4.5	25.5	17	M5x0.8	8	7	M6x1.0
25	27.5	-	22.5	-	12	12	40	5.5	11	M6x1.0	9	5.4	5	28	17	M5x0.8	10	7	M6x1.0
32	30	40	23	33	13	16	45	7.5	10.5	M8x1.25	9	5.5	7	34	17	G1/8"	14	7	M6x1.0
40	36.5	46.5	29.5	39.5	13	16	52	8	11	M8x1.25	9	5.5	7	40	17	G1/8"	14	7	M6x1.0
50	38.5	48.5	30.5	40.5	15	20	64	10.5	10.5	M10x1.5	11	6.6	8	50	22	G1/4"	17	8	M8x1.25
63	44	54	36	46	15	20	77	10.5	15	M10x1.5	14	9	8	60	28.5	G1/4"	17	10.5	M10x1.5
80	53.5	63.5	43.5	53.5	21	25	98	12.5	16	M16x2.0	17.5	11	10	77	35.5	G3/8"	22	13.5	M12x1.75
100	65	75	53	63	27	30	117	13	23	M20x2.5	17.5	11	12	94	35.5	G3/8"	27	13.5	M12x1.75

Magnetic Dimensions

Ø12 - Ø16

Ø20 - Ø25

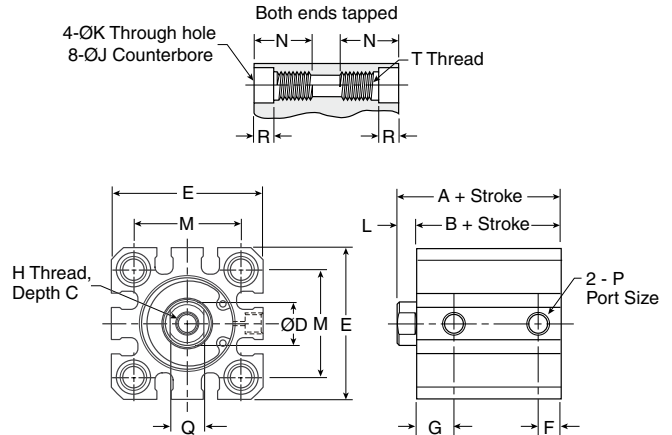
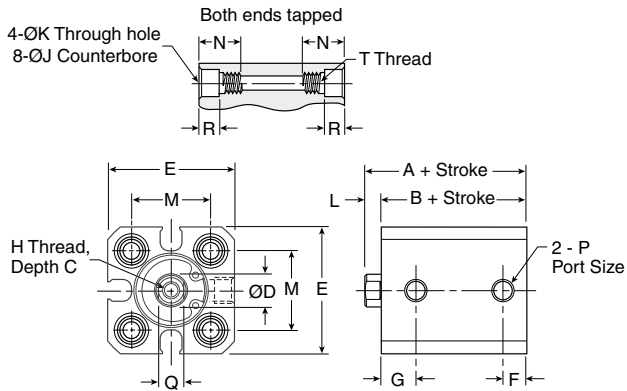

Ø32 - Ø100

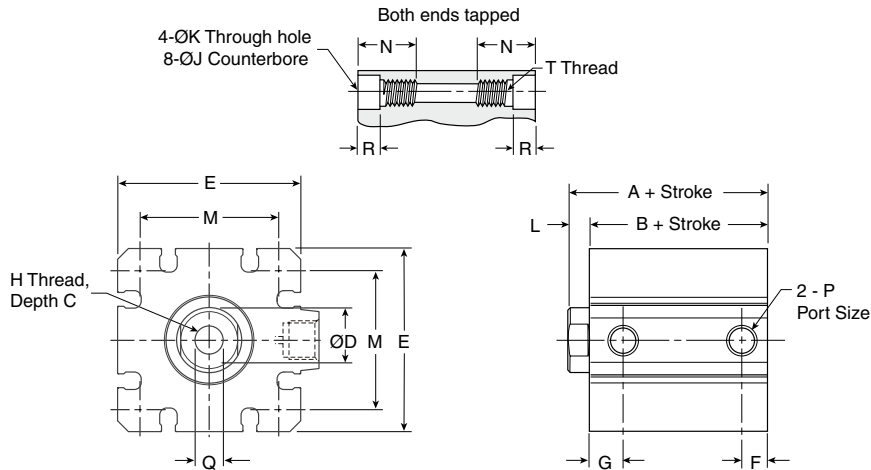

Dimensions

Bore size	A	B	C	D	E	F	G	H	J	K	L	M	N	P	Q	R	T
12	25.5	22	6	6	25	5	7.5	M3x0.5	6.5	3.5	3.5	15.5	11	M5x0.8	5	4	M4x0.7
16	25.5	22	8	8	29	5	7.5	M4x0.7	6.5	3.5	3.5	20	11	M5x0.8	6	4	M4x0.7
20	34	29.5	7	10	36	5.5	9	M5x0.8	9	5.4	4.5	25.5	17	M5x0.8	8	7	M6x1.0
25	37.5	32.5	12	12	40	5.5	11	M6x1.0	9	5.4	5	28	17	M5x0.8	10	7	M6x1.0
32	40	33	13	16	45	7.5	10.5	M8x1.25	9	5.5	7	34	17	G1/8"	14	7	M6x1.0
40	46.5	39.5	13	16	52	8	11	M8x1.25	9	5.5	7	40	17	G1/8"	14	7	M6x1.0
50	48.5	40.5	15	20	64	10.5	10.5	M10x1.5	11	6.6	8	50	22	G1/4"	17	8	M8x1.25
63	54	46	15	20	77	10.5	15	M10x1.5	14	9	8	60	28.5	G1/4"	17	10.5	M10x1.5
80	63.5	53.5	21	25	98	12.5	16	M16x2.0	17.5	11	10	77	35.5	G3/8"	22	13.5	M12x1.75
100	75	63	27	30	117	13	23	M20x2.5	17.5	11	12	94	35.5	G3/8"	27	13.5	M12x1.75



**Order Code Key**

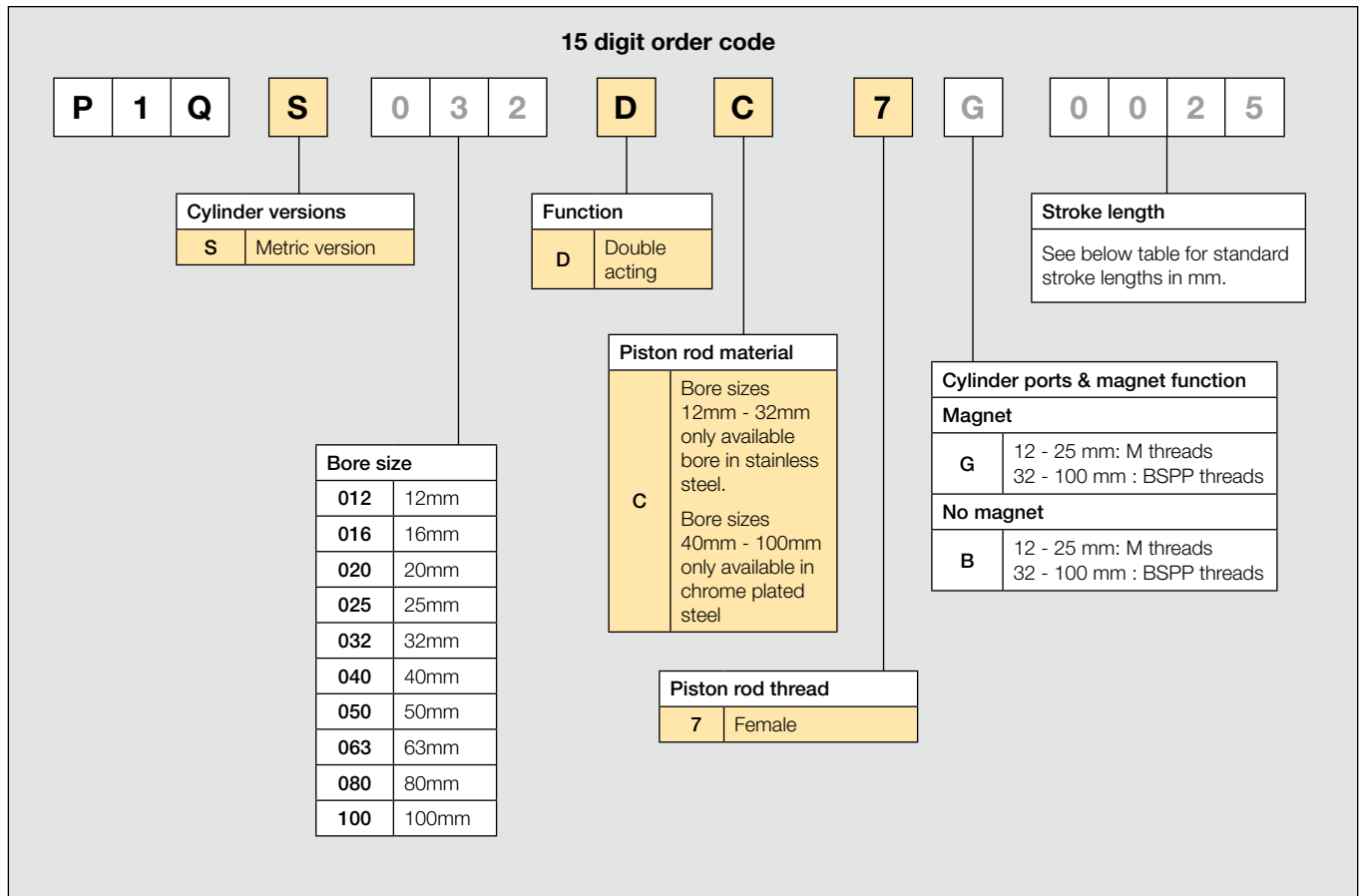

**Standard strokes**

Bore size mm	5	10	15	20	25	30	40	50	75	100
12 - 16	•	•	•	•	•	•				
20 - 25		•	•	•	•	•	•	•		
32		•	•	•	•	•	•	•	•	•
40 - 50			•	•	•	•	•	•	•	•
63 - 100			•	•	•	•	•	•	•	•

## Double Acting/Non Magnetic - Female Threaded Piston Rod



### 12mm

Stroke (mm)	Order Code
5	P1QS012DC7B0005
10	P1QS012DC7B0010
15	P1QS012DC7B0015
20	P1QS012DC7B0020
25	P1QS012DC7B0025
30	P1QS012DC7B0030

### 16mm

5	P1QS016DC7B0005
10	P1QS016DC7B0010
15	P1QS016DC7B0015
20	P1QS016DC7B0020
25	P1QS016DC7B0025
30	P1QS016DC7B0030

### 20mm

10	P1QS020DC7B0010
15	P1QS020DC7B0015
20	P1QS020DC7B0020
25	P1QS020DC7B0025
30	P1QS020DC7B0030
40	P1QS020DC7B0040
50	P1QS020DC7B0050

### 25mm

10	P1QS025DC7B0010
15	P1QS025DC7B0015
20	P1QS025DC7B0020
25	P1QS025DC7B0025
30	P1QS025DC7B0030
40	P1QS025DC7B0040
50	P1QS025DC7B0050

### 32mm

Stroke (mm)	Order Code
10	P1QS032DC7B0010
15	P1QS032DC7B0015
20	P1QS032DC7B0020
25	P1QS032DC7B0025
30	P1QS032DC7B0030
40	P1QS032DC7B0040
50	P1QS032DC7B0050
75	P1QS032DC7B0075
100	P1QS032DC7B0100

### 40mm

15	P1QS040DC7B0015
20	P1QS040DC7B0020
25	P1QS040DC7B0025
30	P1QS040DC7B0030
40	P1QS040DC7B0040
50	P1QS040DC7B0050
75	P1QS040DC7B0075
100	P1QS040DC7B0100

### 50mm

15	P1QS050DC7B0015
20	P1QS050DC7B0020
25	P1QS050DC7B0025
30	P1QS050DC7B0030
40	P1QS050DC7B0040
50	P1QS050DC7B0050
75	P1QS050DC7B0075
100	P1QS050DC7B0100

### 63mm

Stroke (mm)	Order Code
15	P1QS063DC7B0015
20	P1QS063DC7B0020
25	P1QS063DC7B0025
30	P1QS063DC7B0030
40	P1QS063DC7B0040
50	P1QS063DC7B0050
75	P1QS063DC7B0075

### 80mm

15	P1QS080DC7B0015
20	P1QS080DC7B0020
25	P1QS080DC7B0025
30	P1QS080DC7B0030
40	P1QS080DC7B0040
50	P1QS080DC7B0050
75	P1QS080DC7B0075

### 100mm

15	P1QS100DC7B0015
20	P1QS100DC7B0020
25	P1QS100DC7B0025
30	P1QS100DC7B0030
40	P1QS100DC7B0040
50	P1QS100DC7B0050
75	P1QS100DC7B0075

Double Acting/Magnetic -  
Female Threaded Piston Rod



12mm

Stroke (mm)	Order Code
5	P1QS012DC7G0005
10	P1QS012DC7G0010
15	P1QS012DC7G0015
20	P1QS012DC7G0020
25	P1QS012DC7G0025
30	P1QS012DC7G0030

16mm

5	P1QS016DC7G0005
10	P1QS016DC7G0010
15	P1QS016DC7G0015
20	P1QS016DC7G0020
25	P1QS016DC7G0025
30	P1QS016DC7G0030

20mm

10	P1QS020DC7G0010
15	P1QS020DC7G0015
20	P1QS020DC7G0020
25	P1QS020DC7G0025
30	P1QS020DC7G0030
40	P1QS020DC7G0040
50	P1QS020DC7G0050

25mm

10	P1QS025DC7G0010
15	P1QS025DC7G0015
20	P1QS025DC7G0020
25	P1QS025DC7G0025
30	P1QS025DC7G0030
40	P1QS025DC7G0040
50	P1QS025DC7G0050

32mm

Stroke (mm)	Order Code
10	P1QS032DC7G0010
15	P1QS032DC7G0015
20	P1QS032DC7G0020
25	P1QS032DC7G0025
30	P1QS032DC7G0030
40	P1QS032DC7G0040
50	P1QS032DC7G0050
75	P1QS032DC7G0075
100	P1QS032DC7G0100

40mm

15	P1QS040DC7G0015
20	P1QS040DC7G0020
25	P1QS040DC7G0025
30	P1QS040DC7G0030
40	P1QS040DC7G0040
50	P1QS040DC7G0050
75	P1QS040DC7G0075
100	P1QS040DC7G0100

50mm

15	P1QS050DC7G0015
20	P1QS050DC7G0020
25	P1QS050DC7G0025
30	P1QS050DC7G0030
40	P1QS050DC7G0040
50	P1QS050DC7G0050
75	P1QS050DC7G0075
100	P1QS050DC7G0100

63mm

Stroke (mm)	Order Code
15	P1QS063DC7G0015
20	P1QS063DC7G0020
25	P1QS063DC7G0025
30	P1QS063DC7G0030
40	P1QS063DC7G0040
50	P1QS063DC7G0050
75	P1QS063DC7G0075

80mm

15	P1QS080DC7G0015
20	P1QS080DC7G0020
25	P1QS080DC7G0025
30	P1QS080DC7G0030
40	P1QS080DC7G0040
50	P1QS080DC7G0050
75	P1QS080DC7G0075

100mm

15	P1QS100DC7G0015
20	P1QS100DC7G0020
25	P1QS100DC7G0025
30	P1QS100DC7G0030
40	P1QS100DC7G0040
50	P1QS100DC7G0050
75	P1QS100DC7G0075

Flange mounting



Intended for fixed mounting of cylinder. Flange can be fitted to front or rear of cylinder.

**Material**

Flange: surface treated steel

Supplied complete with mounting screws for attachment to cylinder.

**Ø12 - Ø25**

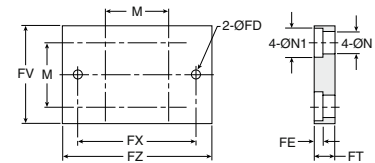

**Ø32 - Ø100**

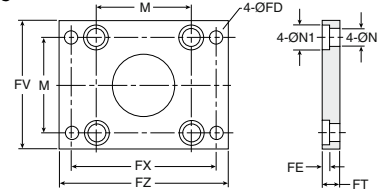

Bore size	FD mm	FT mm	FV mm	FX mm	FZ mm	M mm	N mm	N1 mm	Weight kg	Part number
12	4.5	5.5	25	45	55	15.5	4.5	7.5	0.08	P1Q-4DMB
16	4.5	5.5	30	45	55	20	4.5	7.5	0.10	P1Q-4FMB
20	6.5	8	39	48	60	25.5	6.5	10.5	0.16	P1Q-4HMB
25	6.5	8	42	52	64	28	6.5	10.5	0.20	P1Q-4JMB
32	5.5	8	48	56	65	34	6.5	10.5	0.23	P1Q-4KMB
40	5.5	8	54	62	72	40	6.5	10.5	0.28	P1Q-4LMB
50	6.5	9	67	76	89	50	8.5	13.5	0.53	P1Q-4MMB
63	9	9	80	92	108	60	10.5	16.5	0.71	P1Q-4NMB
80	11	11	99	116	134	77	12.5	18.5	1.59	P1Q-4PMB
100	11	11	117	136	154	94	12.5	18.5	2.19	P1Q-4QMB

Foot mounting



Intended for fixed mounting of cylinder. Angle bracket can be fitted to front and rear of cylinder.

**Material**

Angle bracket: surface treated steel

Supplied in pairs with mounting screws for attachment to cylinder.

\* Weight per item

**Ø12 - Ø25**

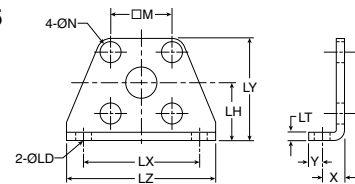

**Ø32 - Ø100**

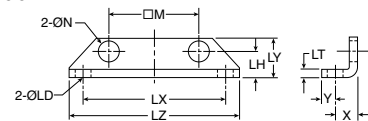

Bore size	LD mm	LH mm	LT mm	LX mm	LY mm	LZ mm	X mm	Y mm	M mm	N mm	Weight kg	Part number
12	4.5	17	2	34	29.5	44	8	4.5	15.5	4.5	0.02*	P1Q-4DMF
16	4.5	19	2	38	33.5	48	8	5	20	4.5	0.02*	P1Q-4FMF
20	6.5	24	3.2	48	42	62	9.2	5.8	25.5	6.5	0.04*	P1Q-4HMF
25	6.5	26	3.2	52	46	66	10.7	5.8	28	6.5	0.05*	P1Q-4JMF
32	6.5	13	3.2	57	20	71	11.2	5.8	34	6.5	0.06*	P1Q-4KMF
40	6.5	13	3.2	64	20	78	11.2	7	40	6.5	0.08*	P1Q-4LMF
50	8.5	14	3.2	79	22	95	12.2	8	50	8.5	0.16*	P1Q-4MMF
63	10.5	16	3.2	95	26	113	13.7	9	60	10.5	0.25*	P1Q-4NMF
80	13	20.5	4.5	118	32	140	16.5	11	77	13	0.50*	P1Q-4PMF
100	13	24	6	137	36	162	23	11.5	94	13	0.85*	P1Q-4QMF

**Clevis mounting**



Intended for flexible mounting of cylinder. Clevis bracket can be fitted to the rear of cylinder.

**Material**  
 Clevis bracket: surface treated steel, black  
 Supplied complete with mounting screws for attachment to cylinder.

**Ø12 - Ø25**

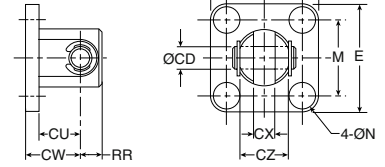

**Ø32 - Ø100**

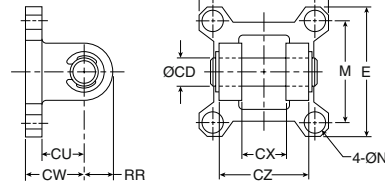

Bore size	CD mm	CU mm	CW mm	CX mm	CZ mm	N mm	RR mm	M mm	E mm	Weight kg	Part number
12	5	9.5	14	5.3	9.8	4.5	6	15.5	25	0.02	<b>P1Q-4DMT</b>
16	5	10.5	15	6.8	11.8	4.5	6	20	29	0.03	<b>P1Q-4FMT</b>
20	8	12.5	18	8.3	15.8	6.5	9	25.5	36	0.05	<b>P1Q-4HMT</b>
25	10	14.5	20	10.3	19.8	6.5	10	28	40	0.06	<b>P1Q-4JMT</b>
32	10	14.5	20	18.3	35.8	6.5	10	34	45.5	0.08	<b>P1Q-4KMT</b>
40	10	15	22	18.3	35.8	6.5	10	40	53.5	0.11	<b>P1Q-4LMT</b>
50	14	20	28	22.3	43.8	8.5	14	50	64.5	0.14	<b>P1Q-4MMT</b>
63	14	21	30	22.3	43.8	10.5	14	60	77.5	0.29	<b>P1Q-4NMT</b>
80	18	28	38	28.3	55.8	12.5	18	77	98.5	0.36	<b>P1Q-4PMT</b>
100	22	32	45	32.3	63.8	12.5	22	94	117.5	0.64	<b>P1Q-4QMT</b>

**Lock nut**



Intended for fixed mounting of accessories to the piston rod.

**Note:**  
 Not sold separately

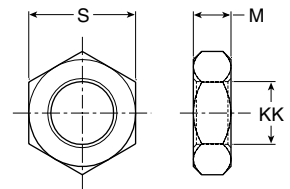

Bore size	KK	M mm	S mm
12	M5 x 0,8	2.7	8
16	M6 x 1,0	3.2	10
20	M8 x 1,25	4.0	13
25	M10 x 1,25	5.0	17
32	M14 x 1,5	7.0	22
40	M14 x 1,5	7.0	22
50	M18 x 1,5	9.0	27
63	M18 x 1,5	9.0	27
80	M22 x 1,5	11.0	32
100	M26 x 1,5	16.0	41

## Global P8S Sensor Series

The P8S family of sensors provides a broad range of reed and solid state sensor types with flying lead or M8 options available. Mounting on all cylinders is within the integrated sensor grooves allowing for compact installation. For 12mm and 16mm bores the sensors can be mounted on 3 sides and on 20mm to 100mm bores on four sides for flexible mounting and ease of installation.

### Electronic Sensors

The electronic sensors utilise "Solid State" technology, providing operation with no moving parts. These switches are available in NPN and PNP type, both provide built in short circuit and transient protection as standard. The solid state operation allows for high switching on off frequency, ideal for applications where long service life is required.

#### Technical data

Design	GMR (Giant Magnetic Resistance) magneto-resistive function
Installation	Mounts within cylinder switch Groove
Outputs	PNP or NPN, normally open
Voltage range	5-30 V DC
Voltage drop	1.5 V max
Switching Current	50 mA max
Switch Rating	1.5 W max
Leakage current	0.01 mA max
Internal consumption	10 mA max (NPN) 12 mA max (PNP)
On/off switching frequency	1000 Hz max
Encapsulation	IP67 (NEMA 6)
Temperature range	-10 °C to +70 °C
Indication	LED Red (NPN) LED Green (PNP)
Cable	Polyurethane

### Reed Sensors

Reed type sensors are based on proven reed switch technology and provide reliable function in many applications. Simple installation and the available AC voltage range are advantages for this range of sensors.

#### Technical data

Design	Reed element
Installation	Mounts within cylinder switch Groove
Output	Normally open
Voltage range	5-120 V DC/AC
Voltage Drop	2.5 V max
Switching Current	100 mA max
Switch Rating	10 W max
Encapsulation	IP67 (NEMA 6)
Temperature range	-10 °C to +70 °C
Indication	LED Red
Cable	Polyurethane

**Electronic sensors**

**Schematic**

**NPN type**

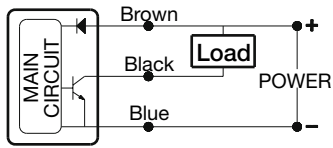

**PNP type**

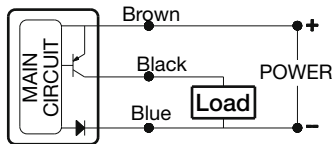

**Dimensions**

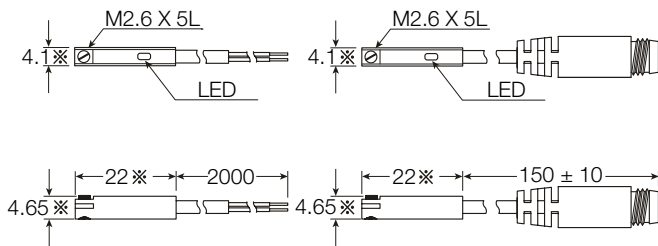

**Reed sensors**

**Schematic**

**Reed type**

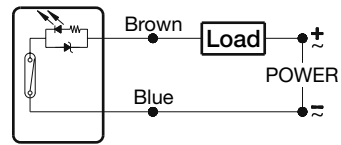

**Dimensions**

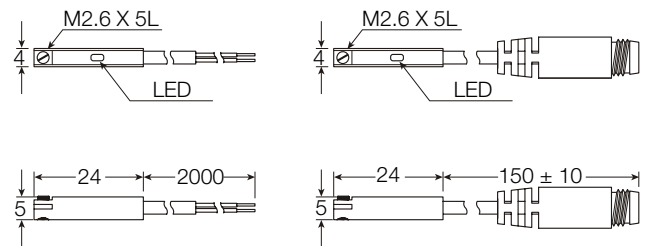

**M8 Quick Connector**

**2 wire QC wiring**

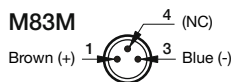

**3 wire QC wiring**

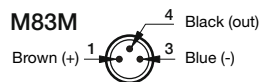

**Electronic and Reed Sensors**

Size	Description	Order code
<b>Flush Mount Style</b>		
PNP Type, normally open	0.165 m cable and M8 screw male connector	<b>P8S-EPSUS</b>
PNP Type, normally open	2 m PUR cable without connector	<b>P8S-EPFXS</b>
NPN Type, normally open	0.165 m cable and M8 screw male connector	<b>P8S-ENSUS</b>
NPN Type, normally open	2 m PUR cable without connector	<b>P8S-ENFXS</b>
Reed Type, normally open	0.15 m cable and M8 screw male connector	<b>P8S-ERSUS</b>
Reed Type, normally open	2 m PUR cable without connector	<b>P8S-ERFXS</b>

### Connecting cables with one connector

The cables have an integral snap-in female connector.



Type of cable	Cable/connector	Weight kg	Order code
<b>Cables for sensors, complete with one female connector</b>			
Cable, Flex PVC	3 m, 8 mm Snap-in connector	0,07	<b>9126344341</b>
Cable, Flex PVC	10 m, 8 mm Snap-in connector	0,21	<b>9126344342</b>
Cable, Super Flex PVC	3 m, 8 mm Snap-in connector	0,07	<b>9126344343</b>
Cable, Super Flex PVC	10 m, 8 mm Snap-in connector	0,21	<b>9126344344</b>
Cable, Polyurethane	3 m, 8 mm Snap-in connector	0,01	<b>9126344345</b>
Cable, Polyurethane	10 m, 8 mm Snap-in connector	0,20	<b>9126344346</b>

### Male connectors for connecting cables

Cable connectors for producing your own connecting cables. The connectors can be quickly attached to the cable without special tools. Only the outer sheath of the cable is removed. The connectors are available for M8 and M12 screw connectors and meet protection class IP 65.



Connector	Weight kg	Order code
M8 screw connector	0,017	<b>P8CS0803J</b>
M12 screw connector	0,022	<b>P8CS1204J</b>

### Ready to use connecting cables with connectors at each end

As accessories the system comprises a large number of different cables in order to meet all requirements that may arise and to make the installation simple, fast and reliable. Cables with moulded 8 mm snap-in round contacts in both ends. The cables are available in two types, one with a straight male and female connectors respectively, and one with a straight 3-pole male connector in one end and an angled 3-pole female connector in the other end.



#### Technical data

##### Contacts

Moulded 8 mm snap-in male/female contacts.

Enclosure IP67

##### Cable

Conductor 3x0,25 mm<sup>2</sup> (32x0,10 mm<sup>2</sup>)

Sheath PVC/PUR

Colour Black

Cables with straight 3-pole male and female connectors respectively.

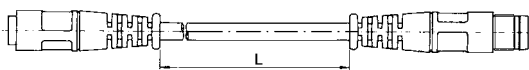

Cables with a straight 3-pole male connector in one end and an angled 3-pole female connector in the other end.

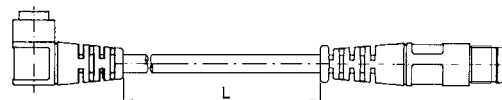

Designation	Weight kg	Order code
Cable with straight contacts, 0,2 m	0,02	<b>9121717014</b>
Cable with straight contacts, 0,3 m	0,02	<b>9121717015</b>
Cable with straight contacts, 0,5 m	0,03	<b>9121717016</b>
Cable with straight contacts, 1,0 m	0,03	<b>9121717017</b>
Cable with straight contacts, 2,0 m	0,05	<b>9121717018</b>
Cable with straight contacts, 3,0 m	0,07	<b>9121717019</b>
Cable with straight contacts, 5,0 m	0,12	<b>9121717020</b>
Cable with straight contacts, 10 m	0,23	<b>9121717021</b>

Designation	Weight kg	Order code
Cable with straight and angled connectors, 0,2 m	0,02	<b>9121717022</b>
Cable with straight and angled connectors, 0,3 m	0,02	<b>9121717023</b>
Cable with straight and angled connectors, 0,5 m	0,03	<b>9121717024</b>
Cable with straight and angled connectors, 1,0 m	0,03	<b>9121717025</b>
Cable with straight and angled connectors, 2,0 m	0,05	<b>9121717026</b>
Cable with straight and angled connectors, 3,0 m	0,07	<b>9121717027</b>
Cable with straight and angled connectors, 5,0 m	0,12	<b>9121717028</b>
Cable with straight and angled connectors, 10 m	0,23	<b>9121717029</b>



# Specifying air quality (purity) in accordance with ISO8573-1:2010, the international standard for Compressed Air Quality

ISO8573-1 is the primary document used from the ISO8573 series as it is this document which specifies the amount of contamination allowed in each cubic metre of compressed air.

ISO8573-1 lists the main contaminants as Solid Particulate, Water and Oil. The purity levels for each contaminant are shown separately in tabular form, however for ease of use, this document combines all three contaminants into one easy to use table.

ISO8573-1:2010 CLASS	Solid Particulate					Water		Oil	
	Maximum number of particles per m <sup>3</sup>					Vapour Pressure Dewpoint	Liquid g/m <sup>3</sup>	Total Oil (aerosol liquid and vapour) mg/m <sup>3</sup>	
	0,1	0,5 micron	0,5	1 micron	1 5 micron				Mass Concentration mg/m <sup>3</sup>
<b>0</b>	As specified by the equipment user or supplier and more stringent than Class 1								
<b>1</b>	≤ 20 000		≤ 400		≤ 10	-	≤ -70 °C	-	0,01
<b>2</b>	≤ 400 000		≤ 6 000		≤ 100	-	≤ -40 °C	-	0,1
<b>3</b>	-		≤ 90 000		≤ 1 000	-	≤ -20 °C	-	1
<b>4</b>	-		-		≤ 10 000	-	≤ +3 °C	-	5
<b>5</b>	-		-		≤ 100 000	-	≤ +7 °C	-	-
<b>6</b>	-		-		-	≤ 5	≤ +10 °C	-	-
<b>7</b>	-		-		-	5 - 10	-	≤ 0,5	-
<b>8</b>	-		-		-	-	-	0,5 - 5	-
<b>9</b>	-		-		-	-	-	5 - 10	-
<b>X</b>	-		-		-	> 10	-	> 10	> 10

## Specifying air purity in accordance with ISO8573-1:2010

When specifying the purity of air required, the standard must always be referenced, followed by the purity class selected for each contaminant (a different purity class can be selected for each contamination if required).

An example of how to write an air quality specification is shown below:

### ISO 8573-1:2010 Class 1.2.1

ISO 8573-1:2010 refers to the standard document and its revision, the three digits refer to the purity classifications selected for solid particulate, water and total oil. Selecting an air purity class of 1.2.1 would specify the following air quality when operating at the standard's reference conditions :

#### Class 1 - Particulate

In each cubic metre of compressed air, the particulate count should not exceed 20,000 particles in the 0.1 - 0.5 micron size range, 400 particles in the 0.5 - 1 micron size range and 10 particles in the 1 - 5 micron size range.

#### Class 2 - Water

A pressure dewpoint (PDP) of -40°C or better is required and no liquid water is allowed.

#### Class 1 - Oil

In each cubic metre of compressed air, not more than 0.01mg of oil is allowed. This is a total level for liquid oil, oil aerosol and oil vapour.

## ISO8573-1:2010 Class zero

- **Class 0 does not mean zero contamination.**
- **Class 0 requires the user and the equipment manufacturer to agree contamination levels as part of a written specification.**
- **The agreed contamination levels for a Class 0 specification should be within the measurement capabilities of the test equipment and test methods shown in ISO8573 Pt 2 to Pt 9.**
- **The agreed Class 0 specification must be written on all documentation to be in accordance with the standard.**
- **Stating Class 0 without the agreed specification is meaningless and not in accordance with the standard.**
- **A number of compressor manufacturers claim that the delivered air from their oil-free compressors is in compliance with Class 0.**
- **If the compressor was tested in clean room conditions, the contamination detected at the outlet will be minimal. Should the same compressor now be installed in typical urban environment, the level of contamination will be dependent upon what is drawn into the compressor intake, rendering the Class 0 claim invalid.**
- **A compressor delivering air to Class 0 will still require purification equipment in both the compressor room and at the point of use for the Class 0 purity to be maintained at the application.**
- **Air for critical applications such as breathing, medical, food, etc typically only requires air quality to Class 2.2.1 or Class 2.1.1.**
- **Purification of air to meet a Class 0 specification is only cost effective if carried out at the point of use.**





# Parker Worldwide

## Europe, Middle East, Africa

**AE – United Arab Emirates,**  
Dubai

Tel: +971 4 8127100  
parker.me@parker.com

**AT – Austria,** Wiener Neustadt

Tel: +43 (0)2622 23501-0  
parker.austria@parker.com

**AT – Eastern Europe,** Wiener  
Neustadt

Tel: +43 (0)2622 23501 900  
parker.easteurope@parker.com

**AZ – Azerbaijan,** Baku

Tel: +994 50 2233 458  
parker.azerbaijan@parker.com

**BE/LU – Belgium,** Nivelles

Tel: +32 (0)67 280 900  
parker.belgium@parker.com

**BY – Belarus,** Minsk

Tel: +375 17 209 9399  
parker.belarus@parker.com

**CH – Switzerland,** Etoy

Tel: +41 (0)21 821 87 00  
parker.switzerland@parker.com

**CZ – Czech Republic,** Klecany

Tel: +420 284 083 111  
parker.czechrepublic@parker.com

**DE – Germany,** Kaarst

Tel: +49 (0)2131 4016 0  
parker.germany@parker.com

**DK – Denmark,** Ballerup

Tel: +45 43 56 04 00  
parker.denmark@parker.com

**ES – Spain,** Madrid

Tel: +34 902 330 001  
parker.spain@parker.com

**FI – Finland,** Vantaa

Tel: +358 (0)20 753 2500  
parker.finland@parker.com

**FR – France,** Contamine s/Arve

Tel: +33 (0)4 50 25 80 25  
parker.france@parker.com

**GR – Greece,** Athens

Tel: +30 210 933 6450  
parker.greece@parker.com

**HU – Hungary,** Budapest

Tel: +36 23 885 475  
parker.hungary@parker.com

**IE – Ireland,** Dublin

Tel: +353 (0)1 466 6370  
parker.ireland@parker.com

**IT – Italy,** Corsico (MI)

Tel: +39 02 45 19 21  
parker.italy@parker.com

**KZ – Kazakhstan,** Almaty

Tel: +7 7272 505 800  
parker.easteurope@parker.com

**NL – The Netherlands,** Oldenzaal

Tel: +31 (0)541 585 000  
parker.nl@parker.com

**NO – Norway,** Asker

Tel: +47 66 75 34 00  
parker.norway@parker.com

**PL – Poland,** Warsaw

Tel: +48 (0)22 573 24 00  
parker.poland@parker.com

**PT – Portugal,** Leca da Palmeira

Tel: +351 22 999 7360  
parker.portugal@parker.com

**RO – Romania,** Bucharest

Tel: +40 21 252 1382  
parker.romania@parker.com

**RU – Russia,** Moscow

Tel: +7 495 645-2156  
parker.russia@parker.com

**SE – Sweden,** Spånga

Tel: +46 (0)8 59 79 50 00  
parker.sweden@parker.com

**SK – Slovakia,** Banská Bystrica

Tel: +421 484 162 252  
parker.slovakia@parker.com

**SL – Slovenia,** Novo Mesto

Tel: +386 7 337 6650  
parker.slovenia@parker.com

**TR – Turkey,** Istanbul

Tel: +90 216 4997081  
parker.turkey@parker.com

**UA – Ukraine,** Kiev

Tel: +380 44 494 2731  
parker.ukraine@parker.com

**UK – United Kingdom,** Warwick

Tel: +44 (0)1926 317 878  
parker.uk@parker.com

**ZA – South Africa,** Kempton Park

Tel: +27 (0)11 961 0700  
parker.southafrica@parker.com

## North America

**CA – Canada,** Milton, Ontario

Tel: +1 905 693 3000

**US – USA,** Cleveland

Tel: +1 216 896 3000

## Asia Pacific

**AU – Australia,** Castle Hill

Tel: +61 (0)2-9634 7777

**CN – China,** Shanghai

Tel: +86 21 2899 5000

**HK – Hong Kong**

Tel: +852 2428 8008

**IN – India,** Mumbai

Tel: +91 22 6513 7081-85

**JP – Japan,** Tokyo

Tel: +81 (0)3 6408 3901

**KR – South Korea,** Seoul

Tel: +82 2 559 0400

**MY – Malaysia,** Shah Alam

Tel: +60 3 7849 0800

**NZ – New Zealand,** Mt Wellington

Tel: +64 9 574 1744

**SG – Singapore**

Tel: +65 6887 6300

**TH – Thailand,** Bangkok

Tel: +662 186 7000-99

**TW – Taiwan,** Taipei

Tel: +886 2 2298 8987

## South America

**AR – Argentina,** Buenos Aires

Tel: +54 3327 44 4129

**BR – Brazil,** Sao Jose dos Campos

Tel: +55 800 727 5374

**CL – Chile,** Santiago

Tel: +56 2 623 1216

**MX – Mexico,** Apodaca

Tel: +52 81 8156 6000

European Product Information Centre

Free phone: 00 800 27 27 5374

(from AT, BE, CH, CZ, DE, DK, EE, ES, FI,  
FR, IE, IL, IS, IT, LU, MT, NL, NO, PL, PT, RU,  
SE, SK, UK, ZA)



### Parker Hannifin Ltd.

Tachbrook Park Drive  
Tachbrook Park,  
Warwick, CV34 6TU  
United Kingdom

Tel.: +44 (0) 1926 317 878

Fax: +44 (0) 1926 317 855

parker.uk@parker.com

www.parker.com



"ARMASER"

Przedsiębiorstwo Handlowo-Usługowe  
Stanisław Zawieja  
98-200 Sieradz; ul. E. Orzeszkowej 3  
NIP: 827-108-05-12

PRZEDSTAWICIEL  
HANDLOWY

Biuro handlowe

98-200 Sieradz; ul. Jana Pawła II 59  
Tel. / fax (43) 822 32 36  
Tel. kom. 602 373 675  
www.armaster.com.pl