

Dystrybutor:



"ARMASER"
Przedsiębiorstwo Handlowo-Usługowe
Stanisław Zawieja
98-200 Sieradz; ul. E. Orzeszkowej 3
NIP: 827-108-05-12

PRZEDSTAWICIEL
HANDLOWY

Biurowie handlowe
98-200 Sieradz; ul. Jana Pawła 11 | 59
Tel. / fax (43) 822 32 36
Tel. kom. 602 373 675
www.armaster.com.pl

Automax

RG Series Heavy Duty Actuator

Double Acting or Spring Return Scotch Yoke Actuator

IP67M Approved



SIL 3 Capable

ATEX Approved

Flow Control Division Automax Valve Automation Systems

Flowserve Corporation's Automax Valve Automation Systems provides complete valve and damper automation to the worldwide processing industries. We provide maximum value to the end user through a broad offering of products, services, application engineering and our systematic approach to automation.



Quality, Dependability and Productivity

Recognized as the leader in valve automation systems, Automax pneumatic actuators can automate valves with torque values from 2.8 - 248600Nm (25 to 2.2 million in-lbs). Actuators are available in a wide range of materials suitable for use in the most demanding applications. Flowserve also offers a comprehensive range of NAMUR Controls and accessories such as lockout modules and gear overrides. To complete the package Flowserve can provide engineering design services for Mounting hardware. To complete the package Flowserve can provide engineering design services for automation mounting brackets, and mounting hardware.



Automax

Accessories

RG Series

Heavy-Duty Scotch Yoke Actuator

Modular Construction

- Double Acting or Spring Return (FCW or FCCW)
- Pneumatic or Hydraulic Pressure Modules
- Torque Module with symmetrical or canted yokes
- Override Options – Direct Drive Jackscrew, Bevel Gear Jackscrew or Hydraulic Override

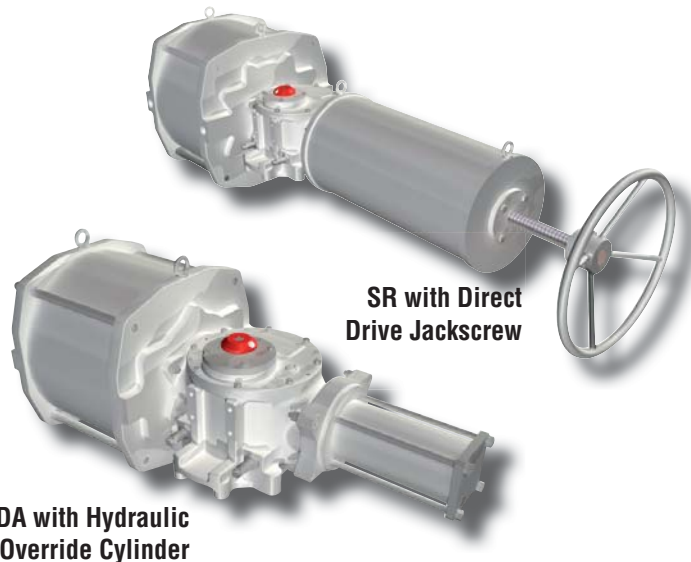

SR with Direct Drive Jackscrew

DA with Hydraulic Override Cylinder

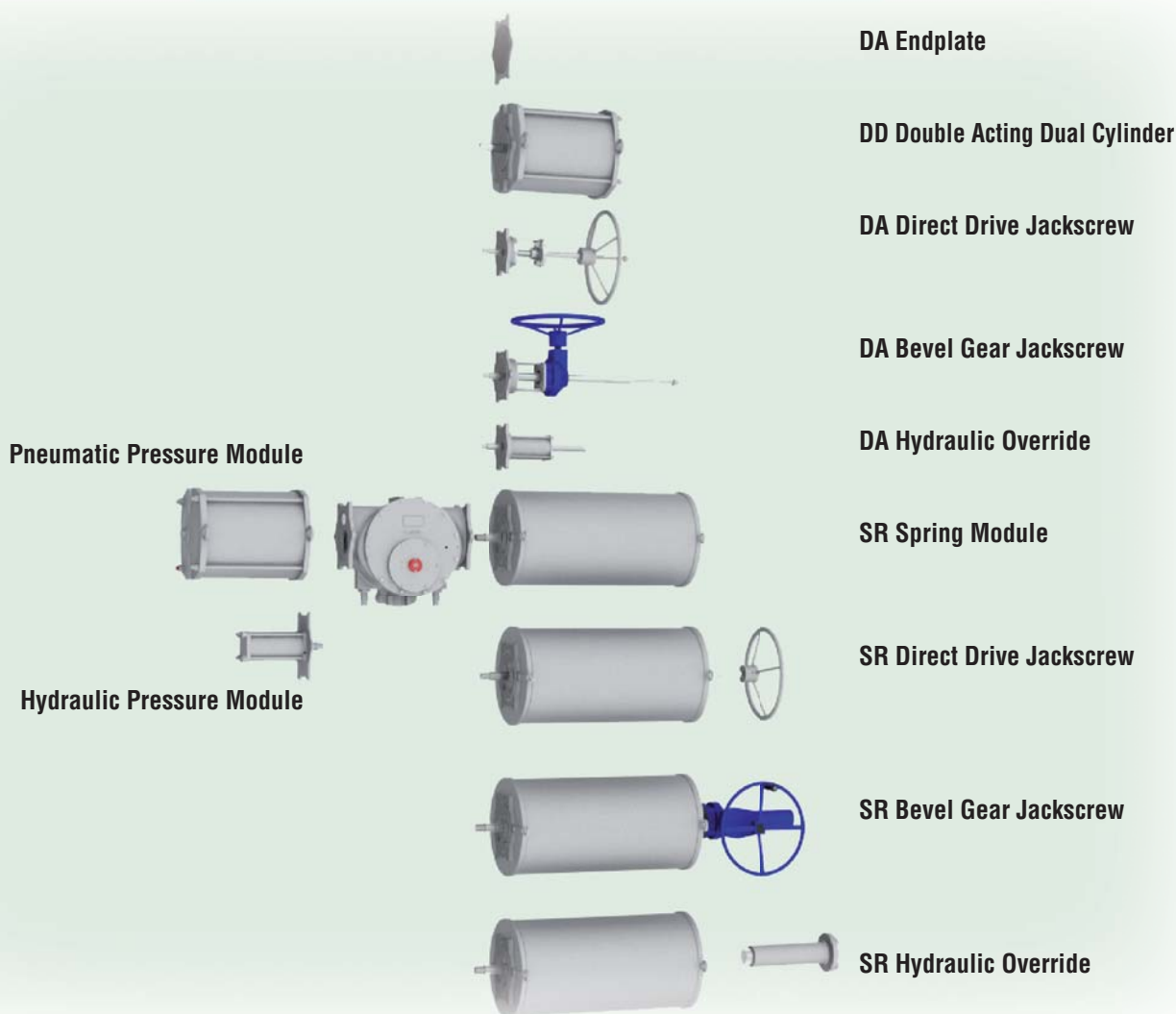

RG Series

Heavy-Duty Scotch Yoke Actuator

The Automax RG Series provides up to 248,000 Nm of heavy-duty Scotch yoke torque. Enhanced performance is achieved by using a superior yoke support system that significantly reduces transverse loads.



Features

- True Modular Design
- On-Off, Multi-Position and Throttling
- Pneumatic, Gas and Hydraulic Models
- Spring Return “Fail Safe” and Double Acting
- Torque Outputs:
 - DA – 248000 Nm (2.2M in-lbs)
 - SR – 124000 Nm (1.2M in-lbs)
- Operating Pressures:
 - Pneumatic: 2.8-10 bar
 - Hydraulic: 34-207 bar

Modular Construction

The Pressure, Torque and Spring Modules are designed for maximum flexibility, reduced envelope dimensions and weight.

IP67M Ingress Protection

O-Rings or dynamic quad seals are utilized to conform to IP67M specifications, ensuring optimal ingress protection.

Guide Bands

Optimizes piston support and extends Quad Seal life with protective wiping action.

Piston Seals

Dynamic Quad Seal design provides enhanced cycle life versus conventional O-Rings.

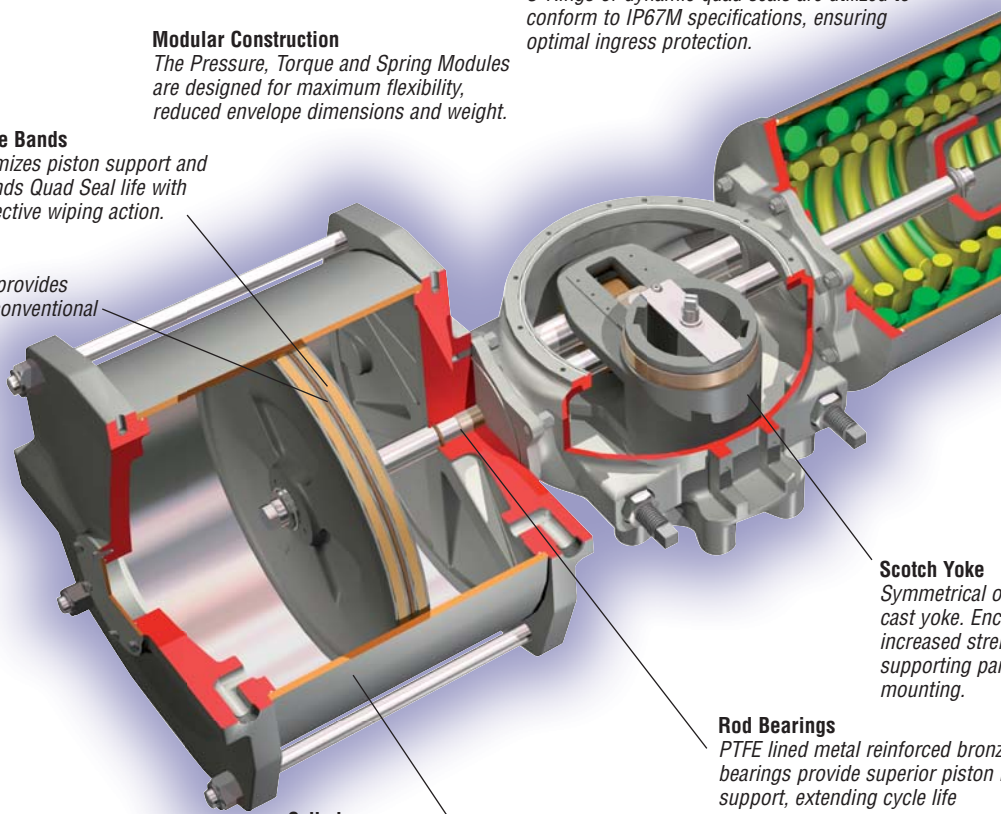

Scotch Yoke

Symmetrical or canted ductile iron cast yoke. Enclosed yoke slot for increased strength with 2 keyways supporting parallel or perpendicular mounting.

Rod Bearings

PTFE lined metal reinforced bronze bearings provide superior piston rod support, extending cycle life

Cylinder

Heavy wall cylinders provide increased “job site” durability. Interior surface is honed and hard chrome plated to provide superior corrosion and wear resistance.

RG Series

Heavy-Duty Scotch Yoke Actuator

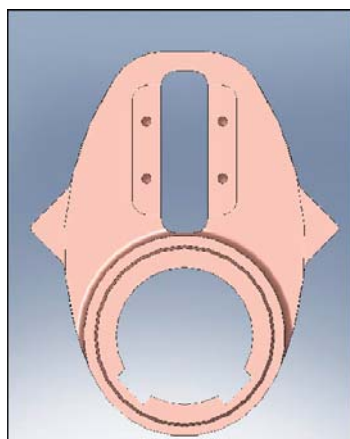

Symmetrical Yoke

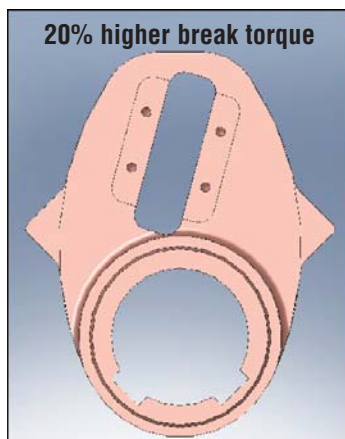

Canted Yoke

Features

- Hard Chrome Plated Cylinder Walls
- Symmetrical and Canted Yoke
- Guide Bar Yoke Support
- Dual DD Cylinder Option
- Field Reversible Action
- Overrides, Line Break and Special Controls
- ESD Performance

Override Options

Spring Module design facilitates field retrofitting of jackscrew or hydraulic overrides

Interchangeable Yoke System

- Ductile iron casting
- Totally enclosed yoke slot for increased strength and cycle life
- Canted yoke results in approx. 20% higher break torque
- 2 keyway provision for flexibility of parallel or perpendicular mounting

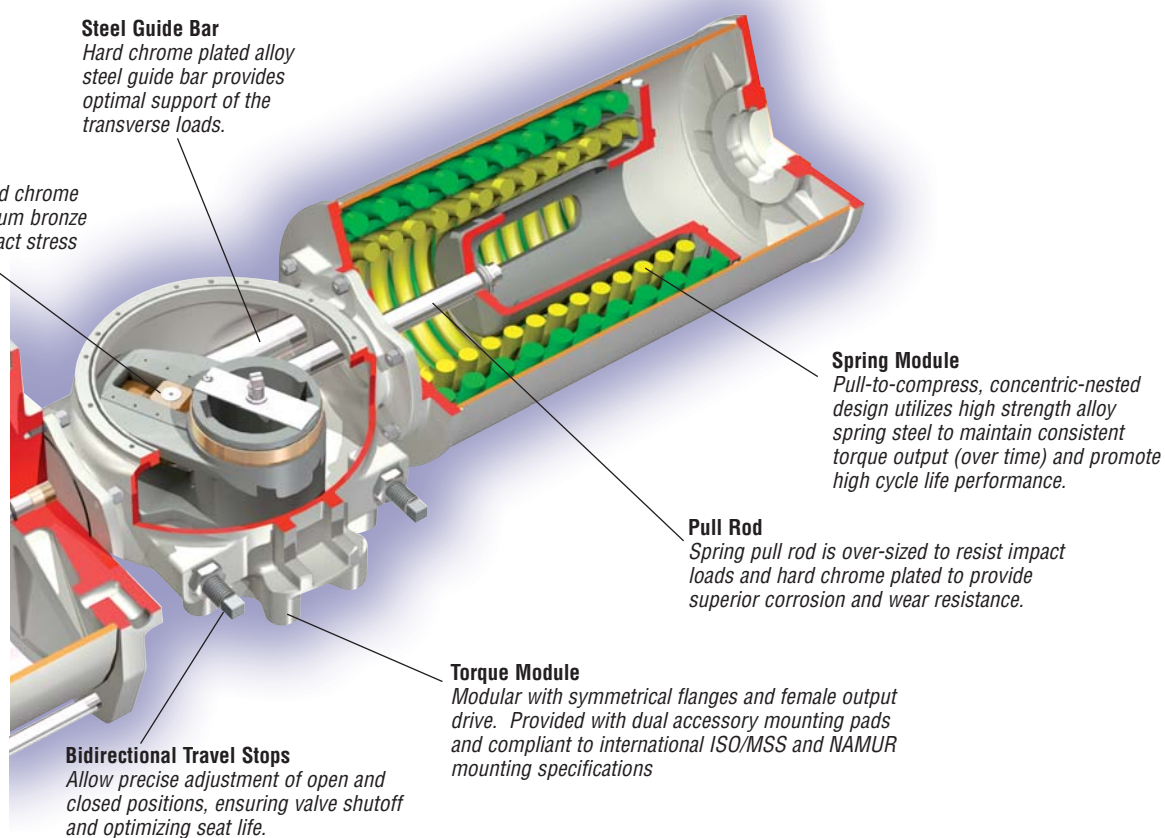

Dimensions

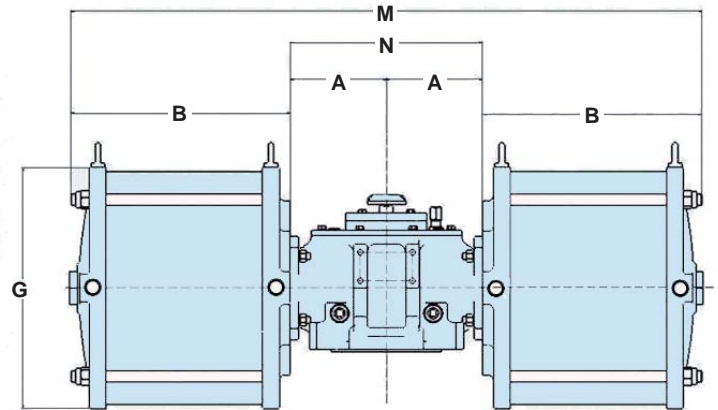
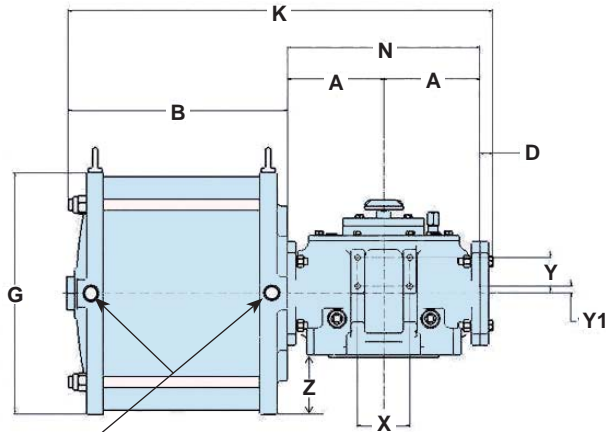
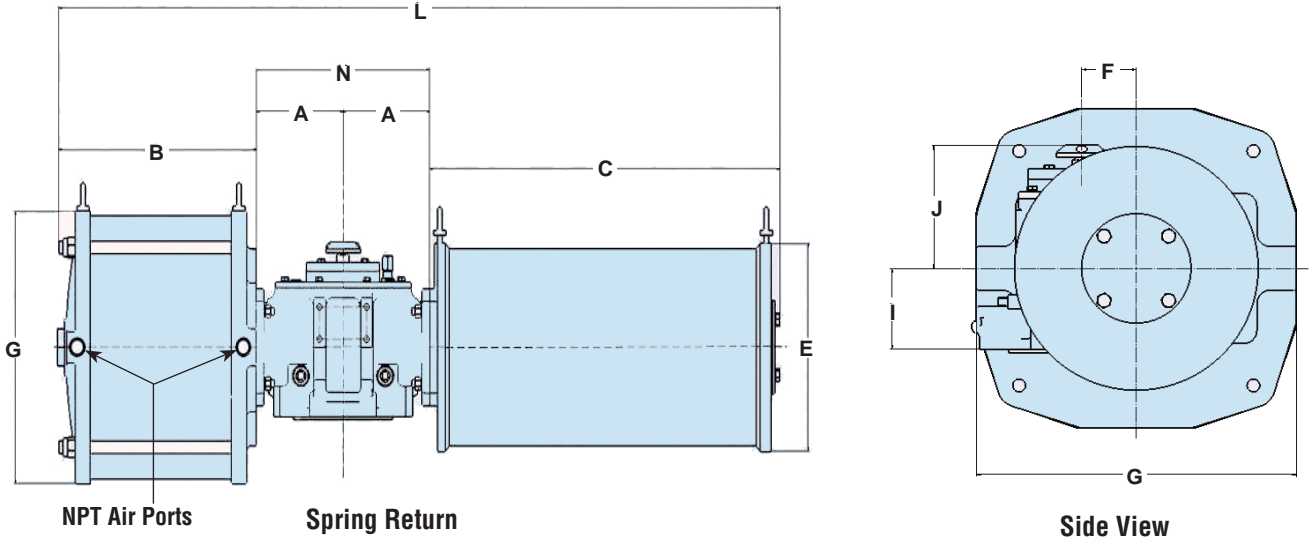

NPT Air Ports Double Acting Single Cylinder

Double Acting Dual Cylinder

Actuator Dimensions, mm (inch)															
SERIES	A	B	C	D	E	F	I	J	K	L	M	N	X	Y	Y1
RG1	141 (5.55)	310 (12.20)	498 (19.61)	18,5 (0.73)	264 (10.39)	55 (2.17)	99 (3.90)	129 (5.08)	610,5 (24.04)	1090 (42.91)	902 (35.51)	282 (11.10)	68 (2.68)	60 (3.36)	30 (1.18)
RG2	162 (6.38)	368 (14.49)	586 (23.07)	20 (0.79)	322 (12.68)	65 (2.56)	116 (4.57)	144 (5.67)	712 (28.03)	1278 (50.31)	1060 (41.73)	324 (12.76)	68 (2.68)	60 (3.36)	30 (1.18)
RG3	175 (6.98)	444 (17.48)	706 (27.80)	23 (0.91)	380 (14.96)	75 (2.95)	111 (4.37)	151 (5.94)	817 (32.17)	1500 (59.06)	1238 (48.74)	350 (13.78)	95 (3.74)	52 (2.05)	13 (0.51)
RG4	243 (9.57)	565 (22.24)	868 (34.17)	23 (0.91)	467 (18.39)	91 (3.58)	145 (5.71)	175 (6.89)	1074 (42.28)	1919 (75.55)	1616 (63.62)	486 (19.13)	95 (3.74)	60 (3.36)	30 (1.18)
RG5	312 (12.28)	716 (28.19)	1008 (39.69)	26 (1.02)	568 (22.36)	145 (5.71)	175,5 (6.91)	189,5 (7.46)	1366 (53.78)	2348 (92.44)	2056 (80.94)	624 (24.57)	95 (3.74)	60 (3.36)	30 (1.18)
RG6	394 (15.51)	756 (29.76)	1640 (64.57)	28 (1.10)	600 (23.62)	185 (7.28)	208 (8.19)	218 (8.58)	1572 (61.89)	3184 (125.35)	2300 (90.55)	788 (31.02)	95 (3.74)	60 (3.36)	30 (1.18)
RG7	500 (19.69)	810 (31.89)	2030 (79.92)	50 (1.97)	615 (24.21)	220 (8.66)	265 (10.43)	310 (12.20)	1860 (73.23)	3840 (151.18)	2620 (103.18)	1000 (39.37)	95 (3.74)	100 (3.94)	30 (1.18)
RG8	665 (26.18)	860 (33.86)	2600 (102.36)	55 (2.17)	680 (26.77)	280 (11.02)	306 (12.05)	360 (14.17)	2245 (88.39)	4790 (188.58)	3050 (120.08)	1330 (52.36)	95 (3.74)	100 (3.94)	30 (1.18)

Cylinder Size	5"	6"	7"	8"	9"	10"	12"	14"	16"	18"	20"	22"	24"	28"	32"	36"	40"
G	178 (7.01)	178 (7.01)	196 (7.72)	222 (8.74)	248 (9.76)	274 (10.79)	324 (12.76)	375 (14.76)	438 (17.24)	486 (19.13)	532 (20.94)	588 (23.15)	648 (25.51)	865 (34.06)	967 (38.07)	1069 (42.09)	1170 (46.06)
Port Size NPT	3/8"	3/8"	3/8"	3/8"	3/8"	1/2"	3/4"	3/4"	3/4"	1"	1"	1"	1"	1 1/2"	1 1/2"	1 1/2"	2"

Dimensions

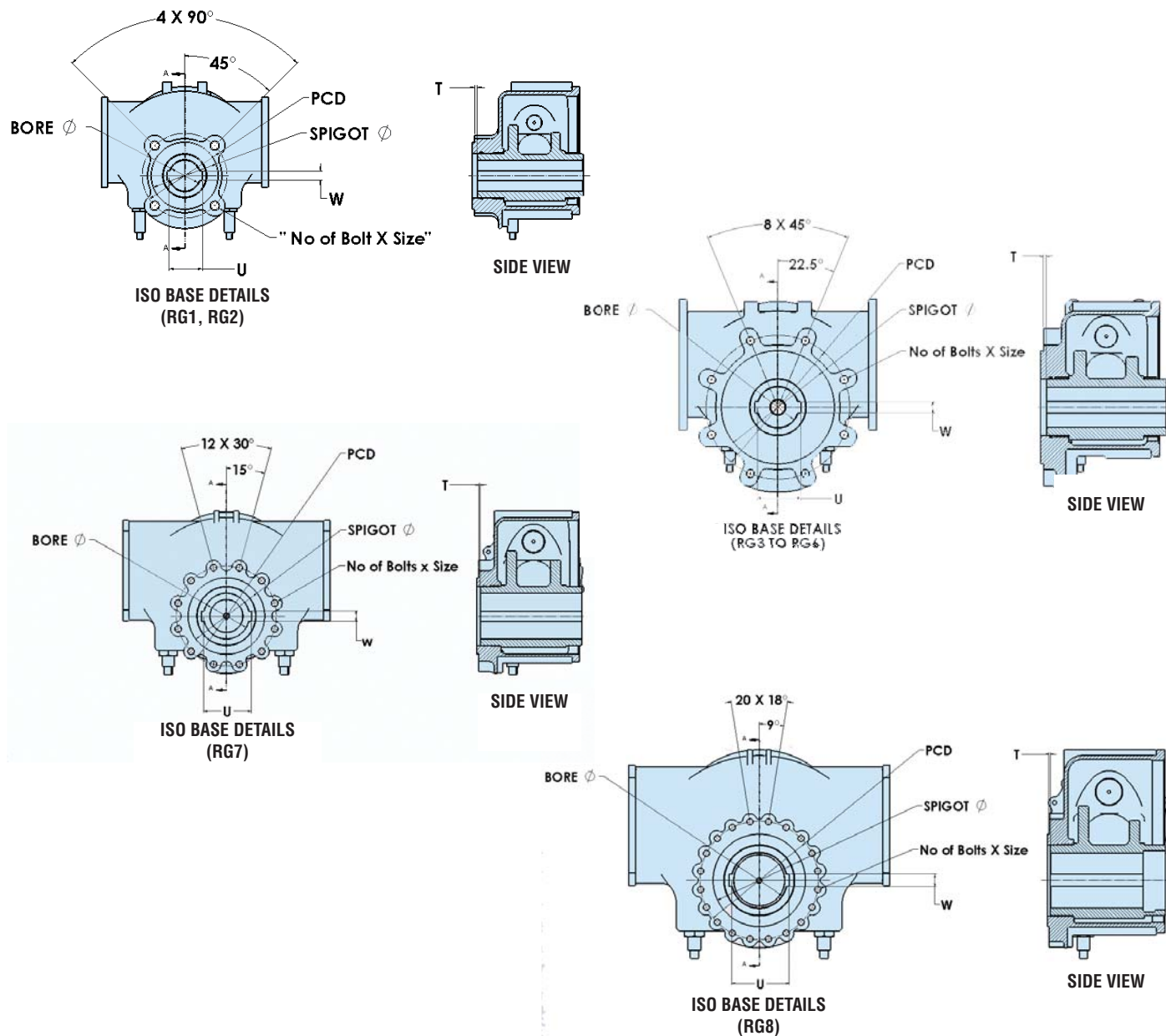

Mounting Base Details & Dimensions, mm (inch)											
SERIES	ISO BASE	SPIGOT Ø	PCD	BORE Ø	BORE Tol	W	W Tol	No of Bolt X Size	T	U	U Tol
RG1	F14	100 (3.94)	140 (5.51)	48 (1.89)	H9	14 (0.55)	+0.12/+0.05	4 X M16	5 (0.20)	51,8 (2.04)	+0.2/+0.0
RG2	F16	130 (5.12)	165 (6.50)	60 (2.36)	H9	18 (0.71)	+0.15/+0.07	4 X M20	5 (0.20)	64,4 (2.54)	+0.2/+0.0
RG3	F25	200 (7.87)	254 (10.0)	72 (2.83)	H9	20 (0.79)	+0.15/+0.07	8 X M16	5 (0.20)	76,9 (3.03)	+0.2/+0.0
RG4	F30	230 (9.06)	298 (11.73)	98 (3.86)	H9	28 (1.10)	+0.15/+0.07	8 X M20	5 (0.20)	104,4 (4.11)	+0.2/+0.0
RG5	F35	260 (10.24)	356 (14.02)	160 (6.30)	H9	40 (1.57)	+0.18/+0.08	8 X M30	5 (0.20)	169,4 (6.67)	+0.2/+0.0
RG6	F40	300 (11.81)	406 (15.98)	180 (7.09)	H9	45 (1.77)	+0.18/+0.08	8 X M36	8 (0.20)	190,4 (5.50)	+0.2/+0.0
RG7	F48	370 (14.57)	483 (19.02)	220 (8.66)	H9	50 (1.97)	+0.18/+0.08	12 X M36	8 (0.20)	231,4 (9.11)	+0.3/+0.0
RG8	F60	470 (18.5)	603 (23.74)	280 (11.02)	H9	63 (2.48)	+0.22/+0.10	20 X M36	8 (0.20)	292,4 (11.51)	+0.3/+0.0

Dimensions

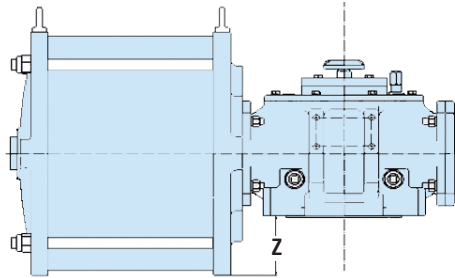

Double Acting Single Cylinder

SERIES	Dimension Z, mm (inch)																
	5"	6"	7"	8"	9"	10"	12"	14"	16"	18"	20"	22"	24"	28"	32"	36"	40"
RG1	-10 (-0.39)	-10 (-0.39)	1 (0.04)	12 (0.47)	25 (0.98)	38 (1.50)	63 (2.48)	-	-	-	-	-	-	-	-	-	-
RG2	-	-	-	5 (0.20)	8 (0.31)	21 (0.83)	46 (1.81)	71,5 (2.81)	103 (4.06)	-	-	-	-	-	-	-	-
RG3	-	-	-	-	-	26 (1.02)	51 (2.01)	76,5 (3.01)	108 (4.25)	132 (5.20)	155 (6.10)	-	-	-	-	-	-
RG4	-	-	-	-	-	-	-	42,5 (1.67)	74 (2.91)	98 (3.86)	121 (4.76)	149 (5.87)	179 (7.05)	-	-	-	-
RG5	-	-	-	-	-	-	-	-	43,5 (1.71)	67,5 (2.66)	90,5 (3.56)	118,5 (4.67)	148,5 (5.85)	257 (10.12)	-	-	-
RG6	-	-	-	-	-	-	-	-	-	35 (1.38)	58 (2.28)	86 (3.39)	116 (4.57)	224,5 (8.84)	275,5 (10.85)	326,5 (12.85)	-
RG7	-	-	-	-	-	-	-	-	-	-	-	-	59 (2.32)	167,5 (6.59)	218,5 (8.6)	269,5 (10.61)	320 (12.60)
RG8	-	-	-	-	-	-	-	-	-	-	-	-	-	-	177,5 (6.99)	228,5 (9.00)	279 (10.98)

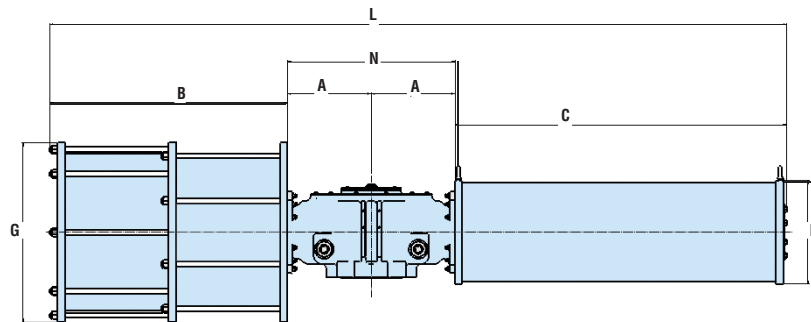

Double Acting Tandem Cylinder

SERIES	Dimensions for Spring Return Tandem Cylinders, mm (inch)						
	A	B	C	E	G	N	L
RG8 32-32	665 (26.18)	1715 (67.52)	2600 (102.36)	680 (26.77)	1170 (46.06)	1330 (52.36)	5645 (222.24)
RG836-36	665 (26.18)	1740 (68.50)	2600 (102.36)	680 (26.77)	1170 (46.06)	1330 (52.36)	5670 (223.23)

Module Weights

Module Weights, kg (Lbs)																									
Model	Torque Module	Pressure Module																Spring Module							
		5	6	7	8	9	10	12	14	16	18	20	22	24	28	32	36	40	1	2	3	4	5	6	7
RG1	31 (68)	14 (31)	16 (35)	22 (47)	24 (53)	30 (66)	43 (94)	63 (139)	-	-	-	-	-	-	-	-	-	40 (88)	44 (97)	46 (101)	47 (103)	48 (106)	52 (114)	54 (119)	54 (119)
RG2	45 (99)	-	-	-	25 (56)	32 (69)	45 (99)	65 (143)	95 (209)	145 (320)	-	-	-	-	-	-	-	58 (128)	66 (145)	70 (154)	72 (158)	72 (158)	78 (172)	82 (180)	85 (186)
RG3	65 (143)	-	-	-	-	45 (100)	64 (142)	91 (200)	145 (318)	185 (406)	255 (561)	-	-	-	-	-	-	103 (226)	118 (260)	121 (267)	122 (269)	125 (276)	150 (330)	146 (321)	-
RG4	134 (295)	-	-	-	-	-	-	99 (217)	154 (339)	194 (427)	266 (586)	337 (741)	428 (942)	-	-	-	-	183 (402)	201 (442)	210 (462)	217 (477)	232 (510)	248 (545)	257 (565)	254 (561)
RG5	231 (510)	-	-	-	-	-	-	-	162 (356)	207 (455)	277 (610)	388 (853)	452 (994)	743 (1634)	-	-	-	290 (639)	335 (737)	350 (770)	356 (783)	410 (901)	434 (955)	-	-
RG6	423 (933)	-	-	-	-	-	-	-	-	224 (493)	280 (616)	391 (861)	478 (1051)	787 (1732)	1055 (2321)	1384 (3044)	-	583 (1283)	790 (1738)	760 (1671)	787 (1730)	937 (2061)	907 (1995)	-	-
RG7	853 (1881)	-	-	-	-	-	-	-	-	-	-	-	-	829 (1824)	1096 (2411)	1435 (3156)	1779 (3913)	1038 (2283)	1339 (2946)	1383 (3043)	1444 (3177)	1650 (3630)	1686 (3709)	-	-
RG8	1686 (3718)	-	-	-	-	-	-	-	-	-	-	-	-	984 (2165)	1282 (2819)	1533 (3372)	1891 (4159)	2103 (4627)	2367 (5200)	2779 (6113)	2830 (6227)	3232 (7111)	3374 (7423)	-	-

NAMUR shaft height and bracket mounting details

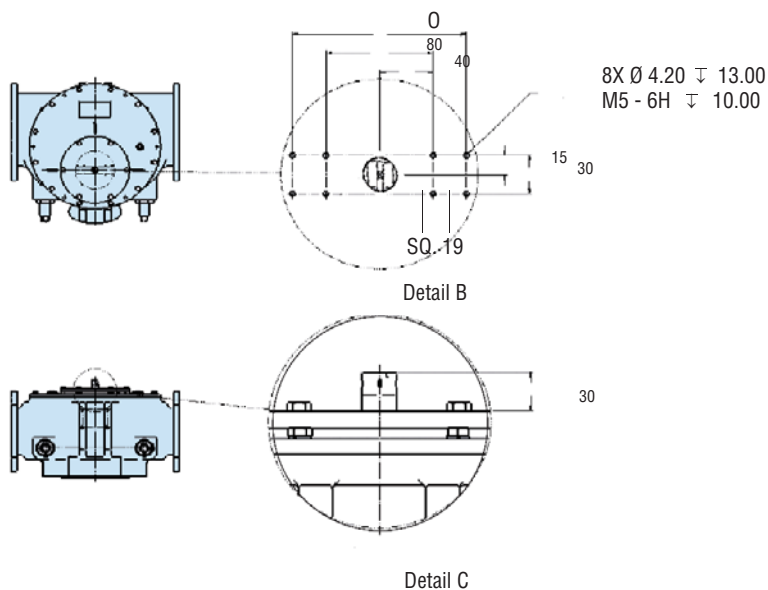

Series	Ø
RG1	-
RG2	-
RG3	-
RG4	130
RG5	130
RG6	130
RG7	130
RG8	130

Agency & Environmental Approvals

- IP67M (1 meter depth for 30 minutes)
- IEC 61508 SIL 3 Suitable
- ATEX Certified

Standard Paint Specification

The standard external surface treatment consists of a 2 pack primer and 2 pack epoxy coating. This international marine coating is suitable for chemical, coastal and offshore environments providing superior corrosion resistance.

- Primer Coat:** Akzo Nobel Intergard 251, anticorrosive zinc phosphate epoxy primer, 75 microns DFT, color: KGA902-Red.
- Top Coat:** Akzo Nobel Intergard 740 epoxy finish, 2 mills DFT
- Finished Color:** ECK724 – Storm Grey, High Gloss

Product Specification

- Actuator shall be designed in accordance with EN15714-3 to define minimum cycle life performance and designed for on-off and modulating service.
- Actuator output shall meet ISO rated torque compliance to provide safe mounting interface and comply with ISO 5211/MSS SP-101 mounting standards and NAMUR VDI/VDE standards for accessory mounting.
- Actuator shall have a symmetrical torque module to simplify field service and interchangeability of spring and air modules. Manual overrides and mounting is consistent for both spring and torque module to simplify mounting.
- The actuator torque module shall utilize an interchangeable yoke system to allow simple field conversion of symmetrical and canted yokes.
- The spring module shall use a pull-to-compress motion with single or concentric-nested springs that are internally supported and guided and weld secured for safety.
- The spring module shall be designed for minimum length and weight to improve the center of gravity, reduce material stress and assembly support requirements.
- The actuator shall have hard chrome plated cylinder walls to provide superior corrosion and wear resistance.
- The actuator piston sealing should use advanced Quad Seal technology to provide enhanced cycle life compared to conventional O-Rings.
- The internal support guide rods, spring rods and piston rods shall be hard chrome plated for superior corrosion and wear resistance.
- The pneumatic cylinder shall use external retention rods to provide visual confirmation and inspection of rod integrity for increased safety.

Actuator Model Designation

How to Order															
Series	Body Size	Cylinder Size				Action	Spring Module	Torque Pattern (Yoke)	Sealing/Temp	Manual Override	Material/ Coatings	Options			
RG	1	05	06	07	08	09	10	12	DA- Double Acting Single Cylinder	0	S- Symmetrical	N- Nitrile, -20° F to 180° F	O- None	GE- Grey Epoxy (std)	00- None
	2	08	09	10	12	14	16	DD- Double Acting Dual Cylinder	1	C- Canted	H- High Temp (Viton), 0° F to 300° F	G- Sandwich Declutch Gbox	PO- Primer Only	TC- Ext. Stopper -CW	
	3	10	12	14	16	18	20	SR- Spring Return Fail CW	2	L- Low Temp, (material) -55° F to 180° F		J- Jackscrew	WE- White Epoxy	TO- Ext. Stopper -CCW	
	4	14	16	18	20	22	24		SO- Spring Return Fail CCW			3	D- Bevel Gear Jackscrew	SP- Specials	TB- Ext. Stopper -Both Dir
	5	16	18	20	22	24	28	4			H- Hydraulic	S xxx- Specials code			
	6	18	20	22	24	28	32	36	5						
	7	24	28	32	36	40		6							
	8	28	32	36	40		7								
							8								

Model Code Example:

RG	5	22	SR	6	C	N	D	GE	TC
----	---	----	----	---	---	---	---	----	----

Manual Override Options

Jackscrew



Hydraulic

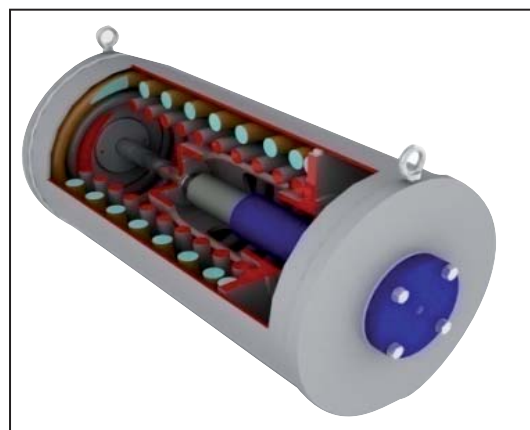

Sandwich Gear

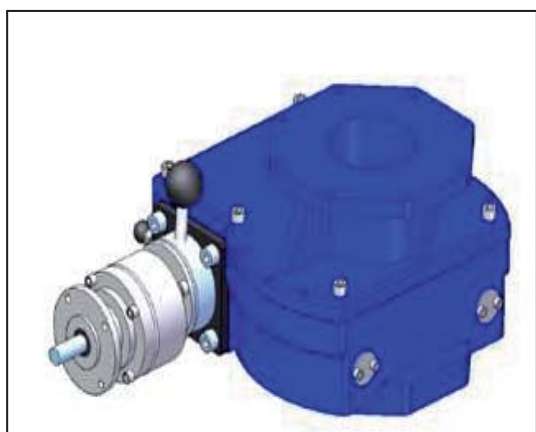

Bevel Gear

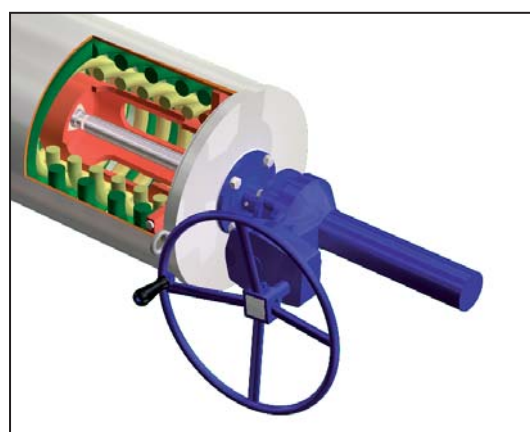

Model	ISO Mounting	Torque		DA				SR			
		N-m	in-lb	Jackscrew		Sandwich Declutchable Gear	Hydraulic	Jackscrew		Sandwich Declutchable Gear	Hydraulic
				Direct Operation	Bevel Gear			Direct Operator	Bevel Gear		
RG1	F14	2000	17702	✓	-	✓	-	✓	-	✓	-
RG2	F16	4000	35404	✓	-	✓	-	✓	-	✓	-
RG3	F25	8001	70808	✓	✓	✓	✓	✓	✓	✓	✓
RG4	F30	16002	141616	-	✓	✓	✓	-	✓	✓	✓
RG5	F35	32005	283232	-	✓	✓	✓	-	✓	✓	✓
RG6	F40	63010	557613	-	-	-	✓	-	-	-	✓
RG7	F48	125020	1106375	-	-	-	✓	-	-	-	✓
RG8	F60	248600	2212750	-	-	-	✓	-	-	-	✓

Sales and service facilities are strategically located in industrial centers throughout the world.

Controls & Accessories

The actuator is the heart of an automation system, but control accessories are important in creating a complete system to meet increasingly sophisticated customer requirements. Solenoid valves and related accessories with NAMUR interfaces provide direct, modular mounting on actuator. Switches, Positioners, Gear Overrides and Lockout Modules can also be integrated into the assembly. Automation mounting brackets, "AutoBrakit" with mounting hardware are engineered to assure consistency and proper alignment

To Access Literature Online

Every item in this catalog has a brochure containing a great deal of technical product detail. It's easy to find... it's free... and you do not need a password.

Do This:

- 1 Go to www.flowserve.com

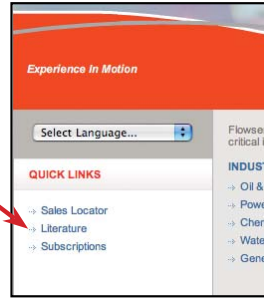

- 2 Click in the box that says "Literature"

- 3 Enter keyword or literature number

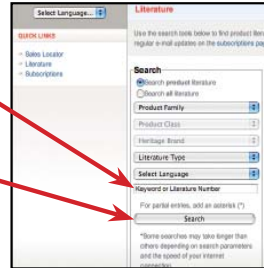

- 4 Click on "Search"

The most recent version of each product bulletin will be available on this site.

- Once you have the PDF, you can:
- read it
 - print it
 - download it
 - even e-mail it

Flowserve Corporation has established industry leadership in the design and manufacture of its products. When properly selected this Flowserve product is designed to perform its intended function safely during its useful life. However, the purchaser or user of Flowserve products should be aware that Flowserve products might be used in numerous applications under a wide variety of industrial service conditions. Although Flowserve can (and often does) provide general guidelines, it cannot provide specific data and warnings for all possible applications. The purchaser/user must therefore assume the ultimate responsibility for the proper sizing and selection, installation, operation, and maintenance of Flowserve products. The purchaser/user should read and understand the Installation Operation Maintenance (IOM) instructions included with the product, and train its employees and contractors in the safe use of Flowserve products in connection with the specific application.

While the information and specifications contained in this literature are believed to be accurate they are supplied for informative purposes only and should not be considered certified or as a guarantee of satisfactory results by reliance thereon. Nothing contained herein is to be construed as a warranty or guarantee, expressed or implied, regarding any matter with respect to this product. Because Flowserve is continually improving and upgrading its product design, the specifications, dimensions and information contained herein are subject to change without notice. Should any question arise concerning these provisions, the purchaser/user should contact Flowserve Corporation at any one of its worldwide operations or offices.

Dystrybutor:



"ARMASER"
Przedsiębiorstwo Handlowo-Usługowe
Stanisław Zawieja
98-200 Sieradz; ul. E. Orzeszkowej 3
NIP: 827-108-05-12

PRZEDSTAWICIEL
HANDLOWY

Biurowie handlowe
98-200 Sieradz; ul. Jana Pawła II 59
Tel. / fax (43) 822 32 36
Tel. kom. 602 373 675
www.armaster.com.pl

Flowserve Flow Control (UK) Ltd.
Burrell Road
Haywards Heath
West Sussex United Kingdom
RH16 1TL
Phone: +44 1444 314400
Fax: +44 1444 314401

Flowserve Flow Control Benelux BV
Rechtzaad 17
4703 RC Roosendaal NB
Netherlands
Phone: +31 165 598 800
Fax: +31 165 555 670

**Flowserve Corporation
Flow Control Division**
1978 Foreman Drive
Cookeville, Tennessee 38501 USA
Phone: +931 432 4021
Fax: +931 432 5518
www.flowserve.com

Flowserve Flow Control GmbH
Rudolf Plank Str. 2
D-76275 Ettlingen
Germany
Phone +49 (0)7243 103 0
Fax +49 (0)7243 103 222

Flowserve Flow Control GmbH
Automax Valve Automation
Im grossen Rohr 2
D-65549 Limburg
Germany
Phone: +49 (0)6431 96610
Fax: +49 (0)6431 966130

Flowserve S.R.L.
Via Prealpi 30
Cormano MI Italy I - 20032
Phone: +39 02 663251
Fax: +39 02 6151863

Flowserve Ahaus GmbH
von-Braun-Str. 19a
48683 Ahaus
Phone: +49 2561 686-119
Fax: +49 2561 686-109

**Flowserve Corporation
Flow Control Division**
1350 North Mountain Springs Parkway
Springville, Utah 84663-0913 USA
Phone: +801 373 3028
Fax: +801 489 2228

Flowserve Corporation
No. 35, Baiyu Road
Suzhou Industrial Park
Suzhou 215021, Jiangsu Province, PRC
Phone: +86-512-6288-1688
Fax: +86-512-6288-8737

Flowserve Australia Pty Ltd
Flow Control Division
14 Dalmore Drive
Scoresby, Victoria 3179
Australia
Phone: +61 3 9759 3300
Fax: +61 3 9759 3301

Flowserve Pte Ltd
No. 12 Tuas Avenue 20
Singapore 638824
Phone: +65 6879 8900
Fax: +65 6862 4940

Unit 01/02/06/07 9F
China Fortune Tower
No. 1568, Century Avenue, Pudong
Shanghai China 200122
Phone: +86 21 38654800
Fax: +86 21 50811781

Flowserve do Brasil Ltda
Rua Tocantins, 128 - Bairro Nova Gerti
São Caetano do Sul,
São Paulo 09580-130 Brazil
Phone: +5511 4231 6300
Fax: +5511 4231 6329 - 423