

ARTICULO: 2025

Válvula de esfera paso total 3 piezas Inoxidable. Stainless steel full port ball valve, 3 piece.

Características

1. Válvula esfera paso total 3 piezas
2. Extremos roscados DIN 2999 Std.
3. Construcción en Inox AISI 316 (CF8M).
4. Asientos PTFE + 15 % Fibra de Vidrio.
5. Tórica en el eje de Viton.
6. Juntas del eje PTFE + 15 % Grafito.
7. Sistema de bloqueo.
8. Montaje actuador directo s/ ISO 5211 (sistema patentado 9900474).
9. Eje inexpulsable.
10. Presión de trabajo máxima 63 Kg/cm2.
11. Temperatura de trabajo -25 °C + 180 °C.

Features

1. Stainless steel full port ball valve, 3 pieces.
2. Thread ends according to DIN 2999 standard.
3. Made of AISI 316 (CF8M).
4. Ball seats PTFE + 15 % G.F.
5. Viton o'ring stem.
6. Stem gasket PTFE + 15 % Graphite.
7. Locking system.
8. Direct mounting actuator ISO 5211 (patent system 9900474).
9. Blow-out proof stem.
10. Max.. Working pressure 63 Kg/cm2.
11. Working Temperature -25 °C + 180 °C.

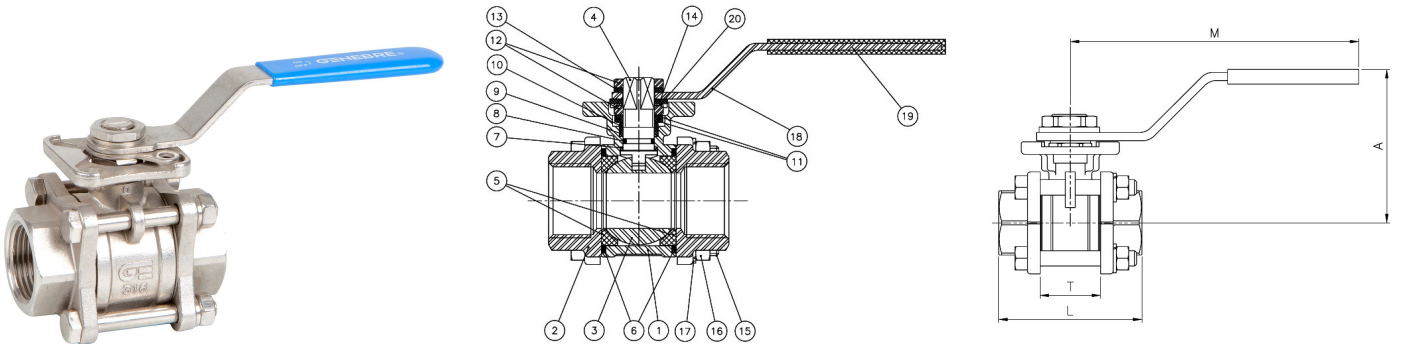

Nº	Denominación / Name	Material	Acabado Superficial/Surface Treatment
1	Cuerpo / Body	Acero Inox AISI 316 / SS 316	Granallado / Shot blasting
2	Tapa / Cap	Acero Inox AISI 316 / SS 316	Granallado / Shot blasting
3	Bola / Ball	Acero Inox AISI 316 / SS 316	-----
4	Eje / Stem	Acero Inox AISI 316 / SS 316	-----
5	Asiento / Seat ball	Teflón + 15% FV / PTFE + 15% GF.	-----
6	Junta / Gasket	Teflón + grafito / PTFE + graphite.	-----
7	Arandela / Trust Washer	Teflón + grafito / PTFE + graphite.	-----
8	Tórica / O'ring	Viton	-----
9	Anillo Prensa / Stem packing	PTFE	-----
10	Anillo Prensa / Stem ring	Acero Inox AISI 304 / SS 304	-----
11	Arandela Belleville / Belleville Washer	Acero Inox AISI 301 / SS 301	-----
12	Tuerca / Nut	Acero Inox AISI 304 / SS 304	-----
13	Arandela / Washer	Acero Inox AISI 304 / SS 304	-----
14	Tope / Stopper	Acero Inox AISI 304 / SS 304	-----
15	Tornillo / Bolt	Acero Inox AISI 304 / SS 304	-----
16	Tuerca / Nut	Acero Inox AISI 304 / SS 304	-----

GENEBRE S.A.

FECHA DE REVISIÓN: 29/06/2011

NUMERO DE REVISIÓN: 5

Nº	Denominación / Name	Material	Acabado Superficial/Surface Treatment
17	Arandela Grover / Grover washer	Acero Inox AISI 304 / SS 304	-----
18	Maneta / Handle	Acero Inox AISI 304 / SS 304	-----
19	Funda / Handle Sleeve	Vynil	-----
20	Antigiro / Lock Washer	Acero Inox AISI 304 / SS 304	-----

Únicamente en medidas de 2 ½" a 4" / For 2 ½" – 4" Sizes Only

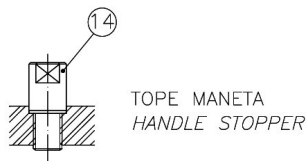

Detalle de la zona de Eje / Stem detail

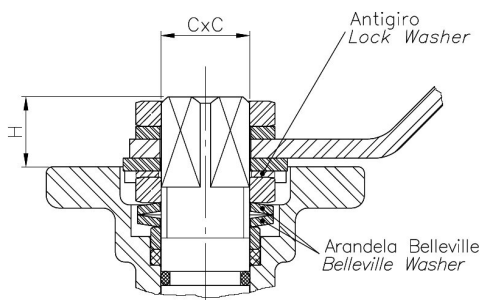

Antigiro / Lock Washer: Previene el desajuste de la tuerca del eje en elevados ciclos de maniobra / *Prevents unthreading of stem nut in high cycle automation applications.*

Arandela Belleville / Belleville Washer: Las arandelas belleville proporcionan una carga constante sobre el prensa asegurando un cierre firme en variaciones de condiciones de trabajo. / *Standard belleville washers provide constant "live load" on the stem seals, assuring a tight seal even varying service parameters.*

DIMENSIONES GENERALES / GENERAL DIMENSIONS

Ref	Medida/Size	PN	Paso	Dimensiones / Dimensions (mm)				Peso/Weight (Kg)
				A	L	M	T	
2025 02	1/4"	63	11	60	47.6	112	23	0.39
2025 03	3/8"	63	12.7	60	47.6	112	23	0.38
2025 04	1/2"	63	15	60	56	112	24	0.44
2025 05	3/4"	63	20	70	73	138	30	0.82
2025 06	1"	63	25	70	82	138	33.5	1.02
2025 07	1 ¼"	63	32	88	91	160	41.5	1.79
2025 08	1 ½"	63	40	94	104	205	51.5	2.46
2025 09	2"	63	50	100	120	205	63	3.47
2025 10	2 ½"	63	65	150	155	330	83.5	8.50
2025 11	3"	63	80	165	182	330	100	12.40
2025 12	4"	63	100	175	220	340	118.5	19.65

Ref	Medida/Size	PN	Dimensiones/Dimensions (mm)		
			H	C x C	ISO 5211
2025 02	1/4"	63	10	9 x 9	F-03
2025 03	3/8"	63	10	9 x 9	F-03
2025 04	1/2"	63	11	9 x 9	F-03/F-04
2025 05	3/4"	63	11	11 x 11	F-04/F-05
2025 06	1"	63	11	11 x 11	F-04/F-05
2025 07	1 1/4"	63	15	14 x 14	F-05/F-07
2025 08	1 1/2"	63	15	14 x 14	F-05/F-07
2025 09	2"	63	15	14 x 14	F-05/F-07
2025 10	2 1/2"	63	19	17 x 17	F-07/F-10
2025 11	3"	63	19	17 x 17	F-07/F-10
2025 12	4"	63	19	17 x 17	F-07/F-10

CURVA PRESION TEMPERATURA / PRESSURE TEMPERATURE RATING

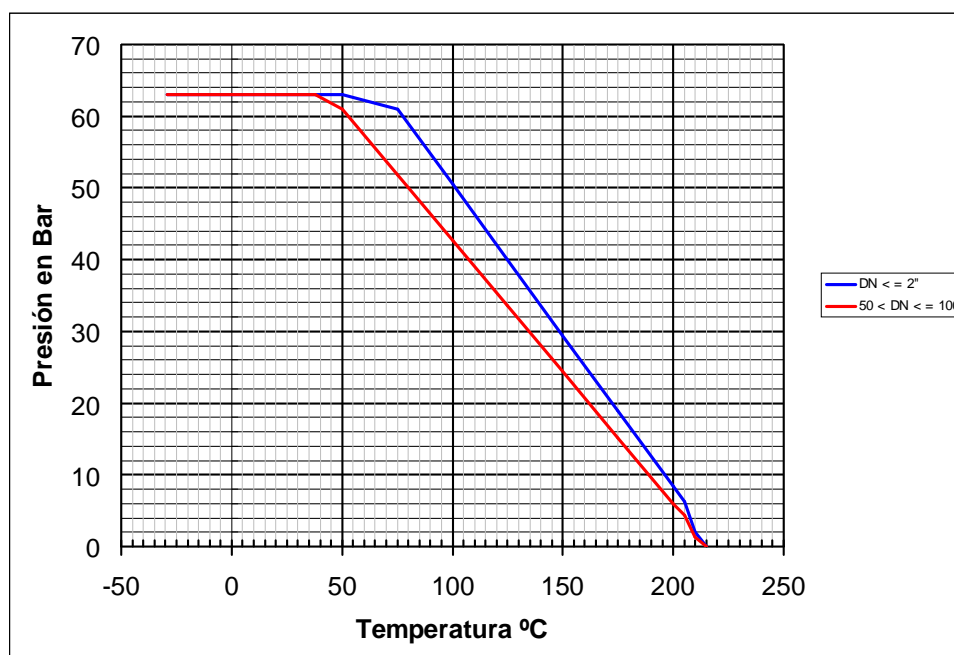

VALORES DE Kv / Kv VALUES

Kv = Es la cantidad de metros cúbicos por hora que pasará a través de la válvula generando una pérdida de carga de 1 bar.

Kv = The rate of flow of water in cubic meter per hour that will generate a pressure drop of 1 bar across the valve.

1/4"	3/8"	1/2"	3/4"	1"	1 1/4"	1 1/2"	2"	2 1/2"	3"	4"
6	10	24	43	83	130	205	340	520	1100	1820